



AGENDA

CAPITOLA PLANNING COMMISSION

Thursday, January 16, 2020 – 7:00 PM

Chairperson TJ Welch
Commissioners Courtney Christiansen
Ed Newman
Mick Routh
Peter Wilk

1. ROLL CALL AND PLEDGE OF ALLEGIANCE

2. NEW BUSINESS

A. Election of Chair and Vice Chair

3. ORAL COMMUNICATIONS

A. Additions and Deletions to Agenda

B. Public Comments

*Short communications from the public concerning matters not on the Agenda.
All speakers are requested to print their name on the sign-in sheet located at the podium so that their name may be accurately recorded in the Minutes.*

C. Commission Comments

D. Staff Comments

4. APPROVAL OF MINUTES

A. Planning Commission - Regular Meeting - Dec 5, 2019 7:00 PM

5. PUBLIC HEARINGS

Public Hearings are intended to provide an opportunity for public discussion of each item listed as a Public Hearing. The following procedure is as follows: 1) Staff Presentation; 2) Public Discussion; 3) Planning Commission Comments; 4) Close public portion of the Hearing; 5) Planning Commission Discussion; and 6) Decision.

A. 1591 Prospect Avenue

#19-0576

APN: 034-044-12

Fence Permit with a location exception and Major Revocable Encroachment Permit for a wall in the public right of way located within the R-1 (Single-Family Residential) zoning district.

This project is in the Coastal Zone but does not require a Coastal Development Permit.

Environmental Determination: Categorical Exemption

Property Owner: Eva Carpenter Trust, Attn: Nancy Yu

Representative: Pedro Rosado, Filed: 10.24.19

B. Brommer Street Improvements #19-0740**APN: N/A**

Coastal Development Permit for roadway improvements on Brommer Street between 41st Avenue and 38th Avenue in the C-C, RM-H, PF-F, and PD Zoning Districts. The improvements include a new sidewalk on the north side of Brommer Street, new striping with Class 2 bike lanes, and roadway repaving.

This project is in the Coastal Zone and requires a Coastal Development Permit which is not appealable to the California Coastal Commission after all possible appeals are exhausted through the City.

Environmental Determination: Categorical Exemption

Property Owner: City of Capitola

Representative: Kailash Mozumder, Filed: 12.17.2019

C. Update to Zoning Ordinance/Local Coastal Plan Implementation Plan

Update to the City of Capitola Zoning Code including Chapter 17.74 Accessory Dwelling Units, density limits in Chapter 17.25 Commercial and Industrial Zoning Districts, and temporary sign standards and non-commercial messaging in Chapter 17.80 Signs.

The Zoning Code serves as the Implementation Plan of the City's Local Coastal Program and therefore must be certified by the Coastal Commission.

Environmental Determination: Addendum to the General Plan Update EIR

Property: The Zoning Code update affects all properties within the City of Capitola.

Representative: Matt Orbach, Associate Planner, City of Capitola

6. DIRECTOR'S REPORT**7. COMMISSION COMMUNICATIONS****8. ADJOURNMENT**

APPEALS: The following decisions of the Planning Commission can be appealed to the City Council within the (10) calendar days following the date of the Commission action: Conditional Use Permit, Variance, and Coastal Permit. The decision of the Planning Commission pertaining to an Architectural and Site Review Design Permit can be appealed to the City Council within the (10) working days following the date of the Commission action. If the tenth day falls on a weekend or holiday, the appeal period is extended to the next business day.

All appeals must be in writing, setting forth the nature of the action and the basis upon which the action is considered to be in error, and addressed to the City Council in care of the City Clerk. An appeal must be accompanied by a five hundred dollar (\$500) filing fee, unless the item involves a Coastal Permit that is appealable to the Coastal Commission, in which case there is no fee. If you challenge a decision of the Planning Commission in court, you may be limited to raising only those issues you or someone else raised at the public hearing described in this agenda, or in written correspondence delivered to the City at, or prior to, the public hearing.

Notice regarding Planning Commission meetings: The Planning Commission meets regularly on the 1st Thursday of each month at 7 p.m. in the City Hall Council Chambers located at 420 Capitola Avenue, Capitola.

Agenda and Agenda Packet Materials: The Planning Commission Agenda and complete Agenda Packet are available on the Internet at the City's website: www.cityofcapitola.org. Need more information? Contact the Community Development Department at (831) 475-7300.

Agenda Materials Distributed after Distribution of the Agenda Packet: Materials that are a public record under Government Code § 54957.5(A) and that relate to an agenda item of a regular meeting of the Planning Commission that are distributed to a majority of all the members of the Planning Commission more than 72 hours prior to that meeting shall be available for public inspection at City Hall located at 420 Capitola Avenue, Capitola, during normal business hours.

Americans with Disabilities Act: Disability-related aids or services are available to enable persons with a disability to participate in this meeting consistent with the Federal Americans with Disabilities Act of 1990. Assisted listening devices are available for individuals with hearing impairments at the meeting in the City Council Chambers. Should you require special accommodations to participate in the meeting due to a disability, please contact the Community Development Department at least 24 hours in advance of the meeting at (831) 475-7300. In an effort to accommodate individuals with environmental sensitivities, attendees are requested to refrain from wearing perfumes and other scented products.

Televised Meetings: Planning Commission meetings are cablecast "Live" on Charter Communications Cable TV Channel 8 and are recorded to be replayed on the following Monday and Friday at 1:00 p.m. on Charter Channel 71 and Comcast Channel 25. Meetings can also be viewed from the City's website: www.cityofcapitola.org.



**DRAFT MINUTES
CAPITOLA PLANNING COMMISSION MEETING
THURSDAY, DECEMBER 5, 2019
7 P.M. – CAPITOLA CITY COUNCIL CHAMBERS**

1. ROLL CALL AND PLEDGE OF ALLEGIANCE

Commissioners Christiansen, Newman, Routh, Wilk, and Chair Welch were all present.

2. ORAL COMMUNICATIONS

A. Additions and Deletions to Agenda

There were 2 attachments related to Item 5.A. and four emails regarding Item 5.D.

B. Public Comments

Cherrie McCoy spoke against Merlone Geier's proposal for Capitola Mall redevelopment and recommended that the project focus solely on improving the area for mall patrons by omitting all proposed housing.

C. Commission Comments

Commissioner Wilk updated the Commission on the Committee on the Environment's progress regarding a City Heritage Tree program. The committee unanimously agreed that the City should provide funds for residents to maintain what is deemed a heritage tree and would like to work towards developing an appropriate policy to be taken before City Council for approval.

Commissioner Routh acknowledged the death of Ron Graves, who was first elected to City Council in 1968 and had a large impact on Capitola. Chair Welch agreed and thanked him for honoring Mr. Graves, who did so much for the City.

D. Staff Comments

3. APPROVAL OF MINUTES

1. Planning Commission - Regular Meeting - Nov 7, 2019 7:00 PM

MOTION: Approve minutes with incorporation of requested edits.

RESULT:	APPROVED [UNANIMOUS]
MOVER:	Edward Newman
SECONDER:	Peter Wilk
AYES:	Newman, Welch, Wilk, Routh, Christiansen

4. CONSENT CALENDAR

A. 706 Gilroy Drive #19-0330 APN: 035-063-12

Design Permit for demolition of an existing one-story single-family residence and construction of a new two-story single-family residence located within the R-1 (Single-Family Residential) zoning district.

This project is in the Coastal Zone and requires a Coastal Development Permit which is not appealable to the California Coastal Commission after all possible appeals are exhausted through the City.

Environmental Determination: Categorical Exemption

Minutes Acceptance: Minutes of Dec 5, 2019 7:00 PM (Approval of Minutes)

Property Owner: Carol Ostergren
Representative: John McKelvey, Architect, Filed: 07.16.2019

MOTION: Approve the Design Permit and Coastal Development Permit with the following Conditions and Findings.

CONDITIONS:

1. The project approval consists of construction of a new 1,760 square-foot single-family residence. The maximum Floor Area Ratio for the 3,096 square foot property is 57% (1,765 square feet). The total FAR of the project is 57% with a total of 1,760 square feet, compliant with the maximum FAR within the zone. The proposed project is approved as indicated on the final plans reviewed and approved by the Planning Commission on December 5, 2019, except as modified through conditions imposed by the Planning Commission during the hearing.
2. Prior to construction, a building permit shall be secured for any new construction or modifications to structures authorized by this permit. Final building plans shall be consistent with the plans approved by the Planning Commission. All construction and site improvements shall be completed according to the approved plans
3. At time of submittal for building permit review, the Conditions of Approval must be printed in full on the cover sheet of the construction plans.
4. At time of submittal for building permit review, Public Works Standard Detail SMP STRM shall be printed in full and incorporated as a sheet into the construction plans. All construction shall be done in accordance with the Public Works Standard Detail BMP STRM.
5. Prior to making any changes to approved plans, modifications must be specifically requested and submitted in writing to the Community Development Department. Any significant changes to the size or exterior appearance of the structure shall require Planning Commission approval.
6. Prior to issuance of building permit, a landscape plan shall be submitted and approved by the Community Development Department. The landscape plan can be produced by the property owner, landscape professional, or landscape architect. Landscape plans shall reflect the Planning Commission approval and shall identify type, size, and location of species and details of any proposed (but not required) irrigation systems.
7. Prior to issuance of building permit, all Planning fees associated with permit #19-0330 shall be paid in full.
8. Prior to issuance of building permit, the developer shall pay Affordable housing in-lieu fees as required to assure compliance with the City of Capitola Affordable (Inclusionary) Housing Ordinance.
9. Prior to issuance of a building permit, the applicant must provide documentation of plan approval by the following entities: Santa Cruz County Sanitation Department, Soquel Creek Water District, and Central Fire Protection District.
10. Prior to issuance of building permits, a drainage plan, grading, sediment and erosion control plan, shall be submitted to the City and approved by Public Works. The plans shall be in compliance with the requirements specified in Capitola Municipal Code Chapter 13.16 Storm Water Pollution Prevention and Protection.
11. Prior to issuance of building permits, the applicant shall submit a stormwater management plan to the satisfaction of the Director of Public Works which implements all applicable Post Construction Requirements (PCRs) and Public Works Standard Details, including all standards relating to low impact development (LID).

12. Prior to any land disturbance, a pre-site inspection must be conducted by the grading official to verify compliance with the approved erosion and sediment control plan.
13. Prior to any work in the City road right of way, an encroachment permit shall be acquired by the contractor performing the work. No material or equipment storage may be placed in the road right-of-way.
14. During construction, any construction activity shall be subject to a construction noise curfew, except when otherwise specified in the building permit issued by the City. Construction noise shall be prohibited between the hours of nine p.m. and seven-thirty a.m. on weekdays. Construction noise shall be prohibited on weekends with the exception of Saturday work between nine a.m. and four p.m. or emergency work approved by the building official. §9.12.010B
15. Prior to a project final, all cracked or broken driveway approaches, curb, gutter, or sidewalk shall be replaced per the Public Works Standard Details and to the satisfaction of the Public Works Department. All replaced driveway approaches, curb, gutter or sidewalk shall meet current Accessibility Standards.
16. Trees approved for removal within this development application may not be removed prior to issuance of a building permit.
17. Prior to issuance of a Certificate of Occupancy, the applicant shall demonstrate compliance with the tree removal permit authorized by this permit for 3 trees to be removed from the property. Five replacement trees shall be planted. Required replacement trees shall be of the same size, species and planted on the site as shown on the approved plans.
18. Prior to issuance of a Certificate of Occupancy, compliance with all conditions of approval shall be demonstrated to the satisfaction of the Community Development Director. Upon evidence of non-compliance with conditions of approval or applicable municipal code provisions, the applicant shall remedy the non-compliance to the satisfaction of the Community Development Director or shall file an application for a permit amendment for Planning Commission consideration. Failure to remedy a non-compliance in a timely manner may result in permit revocation.
19. This permit shall expire 24 months from the date of issuance. The applicant shall have an approved building permit and construction underway before this date to prevent permit expiration. Applications for extension may be submitted by the applicant prior to expiration pursuant to Municipal Code section 17.81.160.
20. The planning and infrastructure review and approval are transferable with the title to the underlying property so that an approved project may be conveyed or assigned by the applicant to others without losing the approval. The permit cannot be transferred off the site on which the approval was granted.
21. Upon receipt of certificate of occupancy, garbage and recycling containers shall be placed out of public view on non-collection days.
22. Prior to issuance of building permits, the building plans must show that the existing overhead utility lines will be underground to the nearest utility pole.
23. Prior to demolition of the existing structure, a pest control company shall resolve any pest issue and document that all pest issues have been mitigated. Documentation shall be submitted to the city at time of demolition permit application.

FINDINGS:

- A. The project, subject to the conditions imposed, secures the purposes of the Zoning Ordinance, General Plan, and Local Coastal Plan.**

Community Development Staff, the Architectural and Site Review Committee, and the Planning Commission have all reviewed the project. The proposed single-family residence complies with the development standards of the Single-Family Residential District. Specifically, all of the requirements of Capitola Municipal Code §17.99.050 have been met. The project secures the purpose of the Zoning Ordinance, General Plan, and Local Coastal Plan

B. The project will maintain the character and integrity of the neighborhood.

Community Development Staff, the Architectural and Site Review Committee, and the Planning Commission have all reviewed the application for the new single-family residence. The design of the home with first-story stucco and metal siding, second-story panel-and-batten siding, and covered front entry will fit in nicely with the existing neighborhood. The project will maintain the character and integrity of the neighborhood.

C. This project is categorically exempt under Section 15303(a) of the California Environmental Quality Act and is subject to Section 753.5 of Title 14 of the California Code of Regulations.

Section 15303(a) of the CEQA Guidelines exempts the construction of one single family residence. This project involves a new single-family home within the R-1 (Single-Family Residential) zoning district. No adverse environmental impacts were discovered during review of the proposed project.

COASTAL FINDINGS:

D. Findings Required.

1. **A coastal permit shall be granted only upon adoption of specific written factual findings supporting the conclusion that the proposed development conforms to the certified Local Coastal Program, including, but not limited to:**
 - a. A statement of the individual and cumulative burdens imposed on public access and recreation opportunities based on applicable factors identified pursuant to subsection (D)(2) of this section. The type of affected public access and recreation opportunities shall be clearly described;
 - b. An analysis based on applicable factors identified in subsection (D)(2) of this section of the necessity for requiring public access conditions to find the project consistent with the public access provisions of the Coastal Act;
 - c. A description of the legitimate governmental interest furthered by any access conditioned required;
 - d. An explanation of how imposition of an access dedication requirement alleviates the access burdens identified.
 - The proposed development conforms to the City's certified Local Coastal Plan (LCP). The specific, factual findings, as per CMC Section 17.46.090(D) are as follows:
2. **Require Project-Specific Findings. In determining any requirement for public access, including the type of access and character of use, the city shall evaluate and document in written findings the factors identified in subsections (D)(2)(a) through (e), to the extent applicable. The findings shall explain the basis for the conclusions and decisions of the city and shall be supported by substantial evidence in the record. If an access dedication is required as a condition of approval, the findings shall explain how the adverse effects which have been identified will be alleviated or mitigated by the dedication. As used in this section, "cumulative effect" means the effect of the individual project in combination with the effects of past projects, other current projects, and probable future projects, including development allowed under applicable planning and zoning.**
 - a. Project Effects on Demand for Access and Recreation. Identification of existing and open public access and coastal recreation areas and facilities in the regional and local vicinity of the development. Analysis of the project's effects upon existing public access and recreation opportunities. Analysis of the project's cumulative effects upon the use and capacity of the identified access and recreation opportunities, including public tidelands and beach resources, and upon the capacity of major coastal roads from subdivision, intensification or cumulative buildout. Projection for the anticipated demand and need for increased coastal

- access and recreation opportunities for the public. Analysis of the contribution of the project's cumulative effects to any such projected increase. Description of the physical characteristics of the site and its proximity to the sea, tideland viewing points, upland recreation areas, and trail linkages to tidelands or recreation areas. Analysis of the importance and potential of the site, because of its location or other characteristics, for creating, preserving or enhancing public access to tidelands or public recreation opportunities;
- The proposed project is located at 706 Gilroy Drive. The home is not located in an area with coastal access. The home will not have an effect on public trails or beach access.
- b. **Shoreline Processes.** Description of the existing shoreline conditions, including beach profile, accessibility and usability of the beach, history of erosion or accretion, character and sources of sand, wave and sand movement, presence of shoreline protective structures, location of the line of mean high tide during the season when the beach is at its narrowest (generally during the late winter) and the proximity of that line to existing structures, and any other factors which substantially characterize or affect the shoreline processes at the site. Identification of anticipated changes to shoreline processes at the site. Identification of anticipated changes to shoreline processes and beach profile unrelated to the proposed development. Description and analysis of any reasonably likely changes, attributable to the primary and cumulative effects of the project, to: wave and sand movement affecting beaches in the vicinity of the project; the profile of the beach; the character, extent, accessibility and usability of the beach; and any other factors which characterize or affect beaches in the vicinity. Analysis of the effect of any identified changes of the project, alone or in combination with other anticipated changes, will have upon the ability of the public to use public tidelands and shoreline recreation areas;
- The proposed project is located along 706 Gilroy Drive. No portion of the project is located along the shoreline or beach.
- c. **Historic Public Use.** Evidence of use of the site by members of the general public for a continuous five-year period (such use may be seasonal). Evidence of the type and character of use made by the public (vertical, lateral, blufftop, etc., and for passive and/or active recreational use, etc.). Identification of any agency (or person) who has maintained and/or improved the area subject to historic public use and the nature of the maintenance performed and improvements made. Identification of the record owner of the area historically used by the public and any attempts by the owner to prohibit public use of the area, including the success or failure of those attempts. Description of the potential for adverse impact on public use of the area from the proposed development (including but not limited to, creation of physical or psychological impediments to public use);
- There is not a history of public use on the subject lot.
- d. **Physical Obstructions.** Description of any physical aspects of the development which block or impede the ability of the public to get to or along the tidelands, public recreation areas, or other public coastal resources or to see the shoreline;
- The proposed project is located on private property on 706 Gilroy Drive. The project will not block or impede the ability of the public to get to or along the tidelands, public recreation areas, or views to the shoreline.
- e. **Other Adverse Impacts on Access and Recreation.** Description of the development's physical proximity and relationship to the shoreline and any public recreation area. Analysis of the extent of which buildings, walls, signs, streets or other aspects of the development, individually or cumulatively, are likely to diminish the public's use of tidelands or lands committed to public recreation. Description of any alteration of the aesthetic, visual or recreational value of public use areas, and of any diminution of the quality or amount of recreational use of public lands which may be attributable to the individual or cumulative effects of the development.
- The proposed project is located on private property that will not impact access and recreation. The project does not diminish the public's use of tidelands or lands committed to public recreation nor alter the aesthetic, visual, or recreational value of public use areas.

- 3. Required Findings for Public Access Exceptions. Any determination that one of the exceptions of subsection (F)(2) applies to a development shall be supported by written findings of fact, analysis and conclusions which address all of the following:**
- The type of access potentially applicable to the site involved (vertical, lateral, bluff top, etc.) and its location in relation to the fragile coastal resource to be protected, the agricultural use, the public safety concern, or the military facility which is the basis for the exception, as applicable;
 - Unavailability of any mitigating measures to manage the type, character, intensity, hours, season or location of such use so that agricultural resources, fragile coastal resources, public safety, or military security, as applicable, are protected;
 - Ability of the public, through another reasonable means, to reach the same area of public tidelands as would be made accessible by an accessway on the subject land.
 - The project is not requesting a Public Access Exception, therefore these findings do not apply.
- 4. Findings for Management Plan Conditions. Written findings in support of a condition requiring a management plan for regulating the time and manner or character of public access use must address the following factors, as applicable:**
- Identification and protection of specific habitat values including the reasons supporting the conclusions that such values must be protected by limiting the hours, seasons, or character of public use;
 - The project is located in a residential area without sensitive habitat areas.
 - Topographic constraints of the development site;
 - The project is located on a flat lot.
 - Recreational needs of the public;
 - The project does not impact the recreational needs of the public.
 - Rights of privacy of the landowner which could not be mitigated by setting the project back from the access way or otherwise conditioning the development;
 - The requirements of the possible accepting agency, if an offer of dedication is the mechanism for securing public access;
 - Feasibility of adequate setbacks, fencing, landscaping, and other methods as part of a management plan to regulate public use.
- 5. Project complies with public access requirements, including submittal of appropriate legal documents to ensure the right of public access whenever, and as, required by the certified land use plan and Section 17.46.010 (coastal access requirements);**
- No legal documents to ensure public access rights are required for the proposed project.
- 6. Project complies with visitor-serving and recreational use policies;**

SEC. 30222

The use of private lands suitable for visitor-serving commercial recreational facilities designed to enhance public opportunities for coastal recreation shall have priority over private residential, general industrial, or general commercial development, but not over agriculture or coastal-dependent industry.

- The project involves a 706 Gilroy Drive on a residential lot of record.

SEC. 30223

Upland areas necessary to support coastal recreational uses shall be reserved for such uses, where feasible.

- The project involves a new single-family home on a residential lot of record.

- c) Visitor-serving facilities that cannot be feasibly located in existing developed areas shall be located in existing isolated developments or at selected points of attraction for visitors.**
- The project involves a new single-family home on a residential lot of record.
- 7. Project complies with applicable standards and requirements for provision of public and private parking, pedestrian access, alternate means of transportation and/or traffic improvements;**
- The project involves the construction of a single-family home. The project complies with applicable standards and requirements for provision for parking, pedestrian access, alternate means of transportation, and/or traffic improvements.
- 8. Review of project design, site plan, signing, lighting, landscaping, etc., by the city's architectural and site review committee, and compliance with adopted design guidelines and standards, and review committee recommendations;**
- The project complies with the design guidelines and standards established by the Municipal Code.
- 9. Project complies with LCP policies regarding protection of public landmarks, protection or provision of public views; and shall not block or detract from public views to and along Capitola's shoreline;**
- The project will not negatively impact public landmarks and/or public views. The project will not block or detract from public views to and along Capitola's shoreline.
- 10. Demonstrated availability and adequacy of water and sewer services;**
- The project is located on a legal lot of record with available water and sewer services.
- 11. Provisions of minimum water flow rates and fire response times;**
- The project is located within close proximity of the Central Fire Protection District Capitola Station. Water is available at the location.
- 12. Project complies with water and energy conservation standards;**
- The project is for a single-family home. The GHG emissions for the project are projected at less than significant impact. All water fixtures must comply with the low-flow standards of the Soquel Creek Water District.
- 13. Provision of park dedication, school impact, and other fees as may be required;**
- The project will be required to pay appropriate fees prior to building permit issuance.
- 14. Project complies with coastal housing policies, and applicable ordinances including condominium conversion and mobile home ordinances;**
- The project does not involve a condo conversion or mobile homes.
- 15. Project complies with natural resource, habitat, and archaeological protection policies;**
- Conditions of approval have been included to ensure compliance with established policies.
- 16. Project complies with Monarch butterfly habitat protection policies;**
- The project is outside of any identified sensitive habitats, specifically areas where Monarch Butterflies have been encountered, identified and documented.
- 17. Project provides drainage and erosion and control measures to protect marine, stream, and wetland water quality from urban runoff and erosion;**
- Conditions of approval have been included to ensure compliance with applicable erosion control measures.

- 18. Geologic/engineering reports have been prepared by qualified professional for projects in seismic areas, geologically unstable areas, or coastal bluffs, and project complies with hazard protection policies including provision of appropriate setbacks and mitigation measures;**
- Geologic/engineering reports have been prepared by qualified professionals for this project. Conditions of approval have been included to ensure the project applicant shall comply with all applicable requirements of the most recent version of the California Building Standards Code.
- 19. All other geological, flood and fire hazards are accounted for and mitigated in the project design;**
- Conditions of approval have been included to ensure the project complies with geological, flood, and fire hazards and are accounted for and will be mitigated in the project design.
- 20. Project complies with shoreline structure policies;**
- The proposed project is not located along a shoreline.
- 21. The uses proposed are consistent with the permitted or conditional uses of the zoning district in which the project is located;**
- This use is an allowed use consistent with the Single-Family Residential zoning district.
- 22. Conformance to requirements of all other city ordinances, zoning requirements, and project review procedures; and**
- The project conforms to the requirements of all city ordinances, zoning requirements, and project development review and development procedures.
- 23. Project complies with the Capitola parking permit program as follows:**
- a. The village area preferential parking program areas and conditions as established in Resolution No. 2596 and no permit parking of any kind shall be allowed on Capitola Avenue.
 - b. The neighborhood preferential parking program areas are as established in Resolution Numbers 2433 and 2510.
 - c. The village area preferential parking program shall be limited to three hundred fifty permits.
 - d. Neighborhood permit areas are only in force when the shuttle bus is operating except that:
 - i. The Fanmar area (Resolution No. 2436) program may operate year-round, twenty-four hours a day on weekends,
 - ii. The Burlingame, Cliff Avenue/Grand Avenue area (Resolution No. 2435) have year-round, twenty-four hour per day “no public parking.”
 - e. Except as specifically allowed under the village parking program, no preferential residential parking may be allowed in the Cliff Drive parking areas.
 - f. Six Depot Hill twenty-four minute “Vista” parking spaces (Resolution No. 2510) shall be provided as corrected in Exhibit A attached to the ordinance codified in this section and found on file in the office of the city clerk.
 - g. A limit of fifty permits for the Pacific Cove parking lot may be issued to village permit holders and transient occupancy permit holders.
 - h. No additional development in the village that intensifies use and requires additional parking shall be permitted. Changes in use that do not result in additional parking demand can be allowed and exceptions for onsite parking as allowed in the land use plan can be made.
- The project site is not located within the area of the Capitola parking permit program.

RESULT:	APPROVED [UNANIMOUS]
MOVER:	Mick Routh
SECONDER:	Courtney Christiansen
AYES:	Newman, Welch, Wilk, Routh, Christiansen

5. PUBLIC HEARINGS**A. 1008 Chittenden Lane****APN: 036-041-30**

Appeal of Notice of Violation issued by Public Works Department
 Environmental Determination: Exempt
 Property Owner: Vieira Enterprises, Inc.
 Representative: Hart King
 Appeal Filed: 10.02.2019

Community Development Director Herlihy said that due to stormwater runoff issues, the City issued a Notice of Violation which was then appealed by the property owner of 1008 Chittenden. She then explained that at this time, Capitola Public Works staff is working with the property owner to address the problem that triggered the violation notice; however, if they stop cooperating, a subcommittee will be formed to address the problem. Director Herlihy asked for two Commissioners to volunteer as members if a subcommittee becomes necessary.

ACTION: COMMISSIONER NEWMAN AND COMMISSION ROUTH VOLUNTEERED TO SERVE ON COMMITTEE, IF NEEDED

B. 1591 Prospect Avenue**#19-0576****APN: 034-044-12**

Fence Permit with a location exception and Major Revocable Encroachment Permit for a wall in the public right of way located within the R-1 (Single-Family Residential) zoning district.

This project is in the Coastal Zone but does not require a Coastal Development Permit.
 Environmental Determination: Categorical Exemption
 Property Owner: Eva Carpenter Trust, Attn: Nancy Yu
 Representative: Pedro Rosado, Filed: 10.24.19

Assistant Planner Sesanto presented the staff report.

Commissioner Newman asked Staff for more information regarding the motivation behind this application. Associate Planner Orbach answered that the practice of granting encroachment permits in sidewalk exempt areas, such as this one, is common in both Depot Hill and the Jewel Box neighborhoods.

Commissioner Christiansen asked about the applicant's removal of the two plum trees.

Chair Welch said that he understands that these encroachment permits have been common but said he personally regrets a few specific past approvals.

Commissioner Newman asked if the encroachment creates an area that would be accessed exclusively by the applicant. Director Herlihy answered that the recorded document is an encroachment permit, not a dedication of exclusive rights.

The applicant's representative, Pedro Rosado, spoke and was available to answer questions. He offered that the applicant could agree to replace the two plum trees.

Commissioner Newman said he would like to get an opinion from the City Attorney about the practice of granting encroachments like the one proposed.

Commissioner Christiansen suggested the applicant put the privacy wall directly on their property line and leave the plum trees and public property as they are.

Commissioner Routh acknowledged that encroachment permits such as this are common along Prospect Avenue and throughout the area.

MOTION: Approve the Fence Permit, Location Exception, and Major Revocable Encroachment Permit.

RESULT:	DENIED [2 TO 3]
MOVER:	Mick Routh
SECONDER:	TJ Welch
AYES:	Welch, Routh
NAYS:	Newman, Wilk, Christiansen

MOTION: Continue item to the next regular Planning Commission meeting on January 16, 2020.

RESULT:	CONTINUED [JANUARY 16, 2020]
MOVER:	Peter Wilk
SECONDER:	Edward Newman
AYES:	Newman, Welch, Wilk, Routh, Christiansen

C. 4170 Gross Road #19-0573 APN: 034-141-24

Conditional Use Permit for a new retail cannabis establishment (The Hook) and a Sign Permit for a new wall sign with a Variance for a second sign on an existing monument sign located within an existing commercial space in the C-R (Regional Commercial) zoning district.

This project is not in the Coastal Zone and does not require a Coastal Development Permit.

Environmental Determination: Categorical Exemption

Property Owner: Robert Lockwood (Lockwood Family Trust)

Representative: William Fisher Architecture, Filed: 10.24.2019

Associate Planner Orbach presented the staff report.

Chair Welch confirmed that Police Chief McManus supported the application.

Courtney Hughes, representative of William Fisher Architecture, spoke with confidence about the quality of the business owner.

Commissioner Wilk asked if the applicant wanted the “green cross” logo present on the second monument sign, to which they said that it was not proposed or desired.

Bryce Berryessa, business owner, said that he has been working closely with Police Captain Dally on the location’s safety plan and that they have a strong working relationship.

Commissioner Routh agreed that the business center is virtually invisible from 41st Avenue so he completely agreed with the request for a variance to allow for a second sign on the existing monument sign.

Director Herlihy said that due to the zoning restrictions in City Code, it had been difficult for applicants to find a viable business site within the allowable six-month window. She brought this to the attention of the Planning Commission as a consideration for future zoning and code changes.

MOTION: Approve the Conditional Use Permit, Sign Permit, and Variance with the following Conditions and Findings.

CONDITIONS:

1. The project approval consists of a conditional use permit for a new retail cannabis establishment (The Hook) and a sign permit for a new wall sign with a variance for a second sign on an existing monument sign. The proposed project is approved as indicated on the final plans reviewed and approved by the Planning Commission on December 5, 2019, except as modified through conditions imposed by the Planning Commission during the hearing.
2. Prior to construction, a building permit shall be secured for any new construction or modifications to structures authorized by this permit. Final building plans shall be consistent with the plans approved by the Planning Commission. All construction and site improvements shall be completed according to the approved plans.
3. At time of submittal for building permit review, the Conditions of Approval must be printed in full on the cover sheet of the construction plans.
4. At time of submittal for building permit review, Public Works Standard Detail SMP STRM shall be printed in full and incorporated as a sheet into the construction plans. All construction shall be done in accordance with the Public Works Standard Detail BMP STRM.
5. Prior to making any changes to approved plans, modifications must be specifically requested and submitted in writing to the Community Development Department. Any significant changes to the size or exterior appearance of the structure shall require Planning Commission approval.
6. Prior to issuance of building permit, all Planning fees associated with permit #19-0573 shall be paid in full.
7. Prior to issuance of a building permit, the applicant must provide documentation of plan approval by the following entities: Santa Cruz County Sanitation Department, Santa Cruz Water District, and Central Fire Protection District.
8. Prior to issuance of building permits, a drainage plan, grading, sediment and erosion control plan, shall be submitted to the City and approved by Public Works. The plans shall be in compliance with the requirements specified in Capitola Municipal Code Chapter 13.16 Storm Water Pollution Prevention and Protection.
9. Prior to issuance of building permits, the applicant shall submit a stormwater management plan to the satisfaction of the Director of Public Works which implements all applicable Post Construction Requirements (PCRs) and Public Works Standard Details, including all standards relating to low impact development (LID).
10. Prior to any land disturbance, a pre-site inspection must be conducted by the grading official to verify compliance with the approved erosion and sediment control plan.
11. Prior to any work in the City road right of way, an encroachment permit shall be acquired by the contractor performing the work. No material or equipment storage may be placed in the road right-of-way.
12. During construction, any construction activity shall be subject to a construction noise curfew, except when otherwise specified in the building permit issued by the City. Construction noise shall be prohibited between the hours of nine p.m. and seven-thirty a.m. on weekdays. Construction noise shall be prohibited on weekends with the exception of Saturday work between nine a.m. and four p.m. or emergency work approved by the building official. §9.12.010B
13. Prior to a project final, all cracked or broken driveway approaches, curb, gutter, or sidewalk shall be replaced per the Public Works Standard Details and to the satisfaction of the Public Works Department. All replaced driveway approaches, curb, gutter or sidewalk shall meet current Accessibility Standards.

14. Prior to issuance of a Certificate of Occupancy, compliance with all conditions of approval shall be demonstrated to the satisfaction of the Community Development Director and Chief of Police. Upon evidence of non-compliance with conditions of approval of the Conditional Use permit and/or the retail cannabis license, or applicable municipal code provisions, the applicant shall remedy the non-compliance to the satisfaction of the Community Development Director and Chief of Police. Failure to remedy a non-compliance in a timely manner may result in conditional use permit revocation and retail cannabis license revocation.
15. This permit shall expire on February 2, 2020, if the applicant has not obtained the appropriate state license(s) for retail sales of cannabis as required under Capitola Municipal Code §5.36.030(A)(7)(e). The applicant shall have an approved building permit and construction underway within 24 months of the Conditional Use approval date to prevent permit expiration.
16. The Cannabis License is subject to the Capitola Municipal Code Section 5.36.030(A)(9) License Transfer to New Owner.
17. Upon receipt of certificate of occupancy, garbage and recycling containers shall be placed out of public view on non-collection days.
18. Sign shall not be directly illuminated except during operating hours.
19. Conditional Use Permit shall only be valid as long as the commercial space is occupied by a business possessing a valid Retail Cannabis License from the City of Capitola.

FINDINGS:

- A. The proposed project is consistent with the general plan, local coastal program, and any applicable specific plan, area plan, or other design policies and regulations adopted by the city council.**
Community Development Staff, the Architectural and Site Review Committee, and the Planning Commission have all reviewed the project. The proposed conditional use permit for a new retail cannabis business and sign permit for a new wall sign with a variance for a second sign on an existing monument sign comply with the development standards of the C-R zoning district. The project secures the purpose of the General Plan and design policies and regulations adopted by the City Council.
- B. The proposed project complies with all applicable provisions of the zoning code and municipal code.**
Community Development Staff, the Architectural and Site Review Committee, and the Planning Commission have all reviewed the application for a conditional use permit for a new retail cannabis business and sign permit for a new wall sign with a variance for a second sign on an existing monument sign. With a variance for the second sign, the project complies with all applicable provisions of the zoning code and municipal code.
- C. The proposed project has been reviewed in compliance with the California Environmental Quality Act (CEQA).**
This project is categorically exempt under Section 15301 of the California Environmental Quality Act and is not subject to Section 753.5 of Title 14 of the California Code of Regulations. The proposed project involves a retail use occupying an existing commercial space previously occupied by a medical school. The project includes no additional floor area. No adverse environmental impacts were discovered during project review by Planning Staff or the Planning Commission.
- D. The proposed development will not be detrimental to the public health, safety, or welfare or materially injurious to the properties or improvements in the vicinity.**
Community Development Staff, the Architectural and Site Review Committee, and the Planning Commission have all reviewed the project. The proposed conditional use permit for a new retail cannabis business and sign permit for a new wall sign with a variance for a second sign on an

existing monument sign will not be detrimental to the public health, safety, or welfare or materially injurious to the properties or improvements in the vicinity.

E. The proposed signs are consistent with the general plan, local coastal program, zoning code, and any applicable specific plan or area plan adopted by the city council.

Community Development Staff and the Planning Commission have reviewed the sign permit application. The proposed wall sign with a variance for a second sign on an existing monument sign are consistent with the general plan and zoning code.

F. The proposed signs comply with all applicable standards in Chapter 17.80 (Signs).

Community Development Staff and the Planning Commission have reviewed the sign permit application. The proposed wall sign complies with all applicable standards in Chapter 17.80 (Signs) and with a variance the nameplate on the existing monument sign complies as well.

G. The proposed sign will not adversely impact the public health, safety, or general welfare.

Community Development Staff and the Planning Commission have reviewed the sign permit application. The proposed wall sign and nameplate on the existing monument sign will not adversely impact the public health, safety, or general welfare.

H. The number, size, placement, design, and material of the proposed signs are compatible with the architectural design of buildings on the site.

Community Development Staff and the Planning Commission have reviewed the sign permit application. The number, size, placement, design, and material of the proposed wall sign and nameplate on the monument sign, with a variance for the second sign on the existing monument sign, are compatible with the architectural design of the buildings on the site.

I. The proposed signs are restrained in character and no larger than necessary for adequate identification.

Community Development Staff and the Planning Commission have reviewed the sign permit application. The proposed wall sign and nameplate on the existing monument sign are restrained in character and no larger than necessary for adequate identification.

RESULT:	APPROVED [UNANIMOUS]
MOVER:	Mick Routh
SECONDER:	Courtney Christiansen
AYES:	Newman, Welch, Wilk, Routh, Christiansen

D. 111 Capitola Avenue #19-0581 APN: 035-241-04

Conditional Use Permit for alcohol sales with a tasting room for a commercial structure located within the C-V (Central Village) zoning district.

This project is in the Coastal Zone but does not require a Coastal Development Permit.

Environmental Determination: Categorical Exemption

Property Owner: John Kettmann

Representative: English Ales Brewery, Filed: 10.28.2019

Associate Planner Orbach presented the staff report.

Director Herlihy told the Planning Commission that though Staff typically offers a strong recommendation on applications, in this case previous permits were analyzed and two options were offered to the Commission based on staff interpretations.

Commissioner Newman asked how approving this permit would impact other sites in the area. Director Herlihy explained that if this application is supported, other, similar, applications could follow and be approved. She said that typically what is not listed in City Code is expressly prohibited, and that since this type of use is not outlined in code it could be prohibited. However, since similar uses

were approved in the past, the application has been brought to the Planning Commission under the previous interpretation of retail sales of alcohol with tasting.

Staff explained that the parking requirement was determined based on the interpretation of use as retail-sales with tasting. Director Herlihy highlighted that the business is not a restaurant and that there will be no food on site.

Commissioner Wilk asked if the Armida Winery tasting room would also be able to have tables if this application is approved, to which Staff answered yes and clarified that the Arminda Winery is not currently limited to no chairs or tables.

Commissioner Newman said that he has no problem with the application and is only concerned with causing a future issue. Commissioner Routh agreed and said that it seems necessary for Staff to develop tasting-room guidelines.

Commissioner Newman explained his concern that this interpretation could be applied in other zoning districts for a CUP modification and be approved, based on this application's approval as precedent.

Chair Welch commented that tasting rooms are popular and thus the City needs clearer rules for this use.

Karen Blackwell-Harrison, daughter of applicant and member of their family business, English Ales Brewery, was available to answer questions.

Commissioner Routh asked about the general rules of the alcohol license, confirming that any bottled alcohol purchased onsite must be consumed offsite. Commissioner Routh expressed concern that patrons could overdrink at this establishment like any bar, since they will be selling 16-ounce beers on tap, however the applicant was adamant that their business is professional and would ensure this would not happen.

In response to a question from Chair Welch, Ms. Blackwell-Harrison explained that the original business British Ales in Marina, California, is their brewery, a pub, and a tasting room.

Joel Campbell, former CEO of Laguna Race Way, supported the business and said they have been clients of hers for 18 years.

Carin Hanna and Rodney Wartzok, Village business owners, each spoke separately about the positives that this business could bring to Capitola Village, especially because it will be open later into the evening than many of the current shops.

MOTION: Approve the Conditional Use Permit with the following Conditions and Findings.

CONDITIONS:

1. The project approval consists of a Conditional Use Permit for alcohol sales (English Ales Brewery) and a 158-square-foot tasting room within a 775-square-foot commercial structure. The proposed project is approved as indicated on the final plans reviewed and approved by the Planning Commission on December 5, 2019, except as modified through conditions imposed by the Planning Commission during the hearing.
2. The primary use on the site is retail related to English Ales Brewery and includes the sale of beer for offsite consumption. The tasting room is limited to a maximum of 160 square feet of area open to customers for tasting with a maximum of 6 seats.
3. A copy of the approved Department of Alcoholic Beverage Control (ABC) Permit must be filed with the Community Development Department prior to initiating on-site beer and wine sales. The Conditional Use Permit is limited to a duplicate Type 23 license through the ABC. A proposed

change in the type of liquor licensed issued by ABC will necessitate approval of an amendment to the Conditional Use Permit.

4. The applicant shall receive permission from ABC prior to December 5, 2021. The conditional use permit will expire in the case where the conditionally permitted use has not been exercised within two years after the date of granting thereof. Any interruption or cessation beyond the control of the property owner shall be deemed to have been “used” when actual substantial, continuous activity has taken place upon the land pursuant to the permit. Applications for extension may be submitted by the applicant prior to permit expiration, pursuant to Municipal Code section 17.81.160.
5. Compliance with all conditions of approval and the ABC license requirements and conditions shall be demonstrated to the satisfaction of the Community Development Director. Upon evidence of non-compliance with conditions of approval or applicable municipal code provisions, the applicant shall remedy the non-compliance to the satisfaction of the Community Development Director or shall file an application for a permit amendment for Planning Commission consideration. Failure to remedy a non-compliance issue in a timely manner may result in permit revocation.
6. There shall be no amplified audible entertainment inside the business that can be audible outside of the business.
7. Prior to construction, a building permit shall be secured for any new construction or modifications to structures authorized by this permit. Final building plans shall be consistent with the plans approved by the Planning Commission. All construction and site improvements shall be completed according to the approved plans.
8. At time of submittal for building permit review, the Conditions of Approval must be printed in full on the cover sheet of the construction plans.
9. At time of submittal for building permit review, Public Works Standard Detail SMP STRM shall be printed in full and incorporated as a sheet into the construction plans. All construction shall be done in accordance with the Public Works Standard Detail BMP STRM.
10. Prior to making any changes to approved plans, modifications must be specifically requested and submitted in writing to the Community Development Department. Any significant changes to the size or exterior appearance of the structure shall require Planning Commission approval.
11. Prior to issuance of building permit, all Planning fees associated with permit #19-0581 shall be paid in full.
12. Prior to any work in the City road right of way, an encroachment permit shall be acquired by the contractor performing the work. No material or equipment storage may be placed in the road right-of-way.
13. During construction, any construction activity shall be subject to a construction noise curfew, except when otherwise specified in the building permit issued by the City. Construction noise shall be prohibited between the hours of nine p.m. and seven-thirty a.m. on weekdays. Construction noise shall be prohibited on weekends with the exception of Saturday work between nine a.m. and four p.m. or emergency work approved by the building official. §9.12.010B
14. Prior to issuance of a Certificate of Occupancy, compliance with all conditions of approval shall be demonstrated to the satisfaction of the Community Development Director. Upon evidence of non-compliance with conditions of approval or applicable municipal code provisions, the applicant shall remedy the non-compliance to the satisfaction of the Community Development Director or shall file an application for a permit amendment for Planning Commission consideration. Failure to remedy a non-compliance in a timely manner may result in permit revocation.

- 15. This permit shall expire 24 months from the date of issuance. The applicant shall have an approved building permit and construction underway before this date to prevent permit expiration. Applications for extension may be submitted by the applicant prior to expiration pursuant to Municipal Code section 17.81.160.
- 16. The planning and infrastructure review and approval are transferable with the title to the underlying property so that an approved project may be conveyed or assigned by the applicant to others without losing the approval. The permit cannot be transferred off the site on which the approval was granted.

FINDINGS:

- A. The project, subject to the conditions imposed, secure the purposes of the Zoning Ordinance, General Plan, and Local Coastal Plan.
Community Development Staff and the Planning Commission have reviewed the project. The proposed retail space with alcohol sales and a tasting room with six seats or less with a duplicate Type 23 alcohol license complies with the development standards of the C-V District. The project secures the purpose of the Zoning Ordinance, General Plan, and Local Coastal Plan.
- B. The project will maintain the character and integrity of the neighborhood.
Community Development Staff and the Planning Commission have reviewed the application for the retail space with alcohol sales and a tasting room with six seats or less with a duplicate Type 23 alcohol license. The use will fit with the surrounding commercial uses. The project will maintain the character and integrity of the neighborhood.
- C. This project is categorically exempt under Section 15301 of the California Environmental Quality Act and is subject to Section 753.5 of Title 14 of the California Code of Regulations. Section 15301 of the CEQA Guidelines exempts the operation, repair, maintenance, permitting, leasing, licensing, or minor alteration of existing public or private structures, facilities, mechanical equipment, or topographical features, involving negligible or no expansion of use beyond that existing at the time of the lead agency’s determination. This project involves a retail space with alcohol sales and a tasting room with six seats or less with a duplicate Type 23 alcohol license for the sale of beer and wine for on-site consumption within the C-V (Central Village) zoning district. No adverse environmental impacts were discovered during review of the proposed project.

RESULT:	APPROVED [4 TO 0]
MOVER:	Peter Wilk, Commissioner
SECONDER:	Courtney Christiansen
AYES:	Welch, Wilk, Routh, Christiansen
ABSTAIN:	Newman

6. DIRECTOR'S REPORT

Community Development Director Herlihy provided a Zoning Code update to the Commission. There are several State changes including those to accessory dwelling units and signs regional commercial zoning requirements that come into effect January 2020.

Director Herlihy outlined the proposed timeline for the Coastal Commission response to Capitola’s City Code, with a meeting held Friday, December 6 to discuss major topics. Adoption hearings will be held as Special Meetings for both Planning Commission and City Council adoption hearings: with target months as April/May 2020 and May/June 2020, respectively.

Director Herlihy announced that the City Council passed the first reading of a sidewalk vending ordinance in response to recent State requirements.

Director Herlihy discussed the 401 Capitola Avenue work that was taking place outside of the approved building permit and conditional use permit. She noted the site was red-tagged. She assured the

Minutes Acceptance: Minutes of Dec 5, 2019 7:00 PM (Approval of Minutes)

Commission that the applicant is now working with the City but was not initially following the appropriate process until Staff intervened. Commissioner Newman asked about the new parking spaces in front of the site and asked that staff follow up with Public Works about the type of parking spaces.

Commissioner Newman asked about the timing of updating the zoning code with specifics about tasting rooms. Director Herlihy agreed that there is a need, however emphasized that adopting the zoning code as soon as possible is the priority.

When asked, Director Herlihy said there is no truth to the rumor that Swenson Builders has cancelled all plans of developing a hotel in the Village. Commissioner Routh also asked about the status of the new business at the old Orchard Supply Hardware site. Director Herlihy said that building staff has been working closely with the new Outdoor Supply Hardware business and that they hope to be open before the Holidays.

7. COMMISSION COMMUNICATIONS – NONE

8. ADJOURNMENT

The meeting was adjourned at 8:24 PM to the next regular meeting of the Planning Commission on January 16, 2020.



STAFF REPORT

TO: PLANNING COMMISSION

FROM: COMMUNITY DEVELOPMENT

DATE: JANUARY 16, 2020

SUBJECT: **1591 Prospect Avenue** **#19-0576** **APN: 034-044-12**

Fence Permit with a location exception and Major Revocable Encroachment Permit for a wall in the public right of way located within the R-1 (Single-Family Residential) zoning district.

This project is in the Coastal Zone but does not require a Coastal Development Permit.

Environmental Determination: Categorical Exemption
 Property Owner: Eva Carpenter Trust, Attn: Nancy Yu
 Representative: Pedro Rosado, Filed: 10.24.19

APPLICANT PROPOSAL

The applicant is proposing to construct a wall and privacy screens located at 1591 Prospect Avenue within the R-1 (Single-Family Residential) zoning district. The application includes a request for a Major Revocable Encroachment Permit and an exception to fence location requirements.

BACKGROUND

On December 5, 2019, the Planning Commission reviewed the application and continued the item to the January 16, 2020, meeting. The Commission requested input from the City Attorney regarding encroachment permits. Specifically, the Commission asked if an encroachment could mature into ownership of public land. Staff has conferred with the City Attorney and addresses this question below. The original staff report with attachments is included as Attachment 1.

DISCUSSION

The applicant is proposing to replace the existing fence with a new plaster and concrete-block wall and three wooden horizontal board privacy screens. The new wall and two of the three privacy screens would encroach into the public right of way along Lincoln Avenue.

Encroachment Permit Issuance

Revocable encroachment permits grant only that which is outlined within the agreement. The encroachment agreement does not grant a property right and cannot become prescriptive over time, particularly against a public agency. (Cal. Civil Code Section 1007: no possession of any right, easement, or other property may ripen into title at any time against a public agency; see also [Laura Vincent Co. v. City of Selma](#) (1941) 43 Cal. 2d 473, 476 [A right to maintain an obstruction cannot be acquired by prescription as against a city.]) Capitola Municipal Code

Section 12.56.070 is consistent with State law requiring all permits for encroachments be revocable and the permittee hold the City harmless from liability for injuries to people/property resulting from the construction/maintenance of the encroachment. Encroachment permits must also include a statement that the City may order removal of the structure and that such removal is at the expense of the owner. §12.56.070 also requires the permittee to hold the City harmless from liability resulting from the construction and maintenance of the encroachment (Attachment 2). Staff has amended the Conditions of Approval to require the applicant to sign a hold harmless agreement form (Conditions #18).

Tree Removals

The Planning Commission also discussed the four significant trees on the site. One oak tree, one magnolia, and two flowering plum trees. Of the four trees, the oak located in the public right-of-way is the most noteworthy. The applicant has designed the wall to go around the oak and agreed to measures intended to protect the tree's root system, which are included as condition #14. The proposed development is not expected to affect the magnolia located on the front corner of 1591 Prospect Avenue.

The two plum trees proposed for removal are in the public right-of-way adjacent to the property along Lincoln Avenue. The northerly plum tree is overshadowed by the oak tree and has a limited canopy due to the lack of sunlight. Trees in the public right-of-way are typically considered the responsibility of the property owners closest to it. Those owners may request the removal of such trees, following the same process and review requirements as trees located on private property set forth in Section 12.12.180. Staff has estimated that post-removal, the lot will retain a canopy coverage of 30 percent, which meets the standards of the Community Tree and Forest Management ordinance and would not require a replanting, pursuant to Section 12.12.180(C)(5).

CEQA

Section 15303(e) of the CEQA Guidelines exempts new accessory structures. No adverse environmental impacts were discovered during review of the proposed project.

RECOMMENDATION

Staff recommends the Planning Commission review the application and approve project #19-0576 based on the following Conditions of Approval and Findings.

CONDITIONS OF APPROVAL

1. The project approval consists of a fence permit for the construction of a new wall and three privacy screens with a fence location exception for a fence in the required side setback area, and a major revocable encroachment permit for the portions of the wall and privacy screens located within the public right of way, and the removal of two flowering plum trees in the public right of way. The proposed project is approved as indicated on the final plans reviewed and approved by the Planning Commission on January 16, 2020, except as modified through conditions imposed by the Planning Commission during the hearing.
2. Prior to construction, a building permit shall be secured for any new construction or modifications to structures authorized by this permit. Final building plans shall be consistent with the plans approved by the Planning Commission. All construction and site improvements shall be completed according to the approved plans

3. At time of submittal for building permit review, the Conditions of Approval must be printed in full on the cover sheet of the construction plans.
4. At time of submittal for building permit review, Public Works Standard Detail SMP STRM shall be printed in full and incorporated as a sheet into the construction plans. All construction shall be done in accordance with the Public Works Standard Detail BMP STRM.
5. Prior to making any changes to approved plans, modifications must be specifically requested and submitted in writing to the Community Development Department. Any significant changes to the size or exterior appearance of the structure shall require Planning Commission approval.
6. Prior to issuance of building permit, a landscape plan shall be submitted and approved by the Community Development Department. The landscape plan can be produced by the property owner, landscape professional, or landscape architect. Landscape plans shall reflect the Planning Commission approval and shall identify type, size, and location of species and details of any proposed (but not required) irrigation systems.
7. Prior to issuance of building permit, all Planning fees associated with permit #19-0567 shall be paid in full.
8. Prior to issuance of building permits, a drainage plan, grading, sediment and erosion control plan, shall be submitted to the City and approved by Public Works. The plans shall be in compliance with the requirements specified in Capitola Municipal Code Chapter 13.16 Storm Water Pollution Prevention and Protection.
9. Prior to issuance of building permits, the applicant shall submit a stormwater management plan to the satisfaction of the Director of Public Works which implements all applicable Post Construction Requirements (PCRs) and Public Works Standard Details, including all standards relating to low impact development (LID).
10. Prior to any land disturbance, a pre-site inspection must be conducted by the grading official to verify compliance with the approved erosion and sediment control plan.
11. Prior to any work in the City road right of way, an encroachment permit shall be acquired by the contractor performing the work. No material or equipment storage may be placed in the road right-of-way.
12. During construction, any construction activity shall be subject to a construction noise curfew, except when otherwise specified in the building permit issued by the City. Construction noise shall be prohibited between the hours of nine p.m. and seven-thirty a.m. on weekdays. Construction noise shall be prohibited on weekends with the exception of Saturday work between nine a.m. and four p.m. or emergency work approved by the building official. §9.12.010B
13. Prior to a project final, all cracked or broken driveway approaches, curb, gutter, or sidewalk shall be replaced per the Public Works Standard Details and to the satisfaction of the Public Works Department. All replaced driveway approaches, curb, gutter or sidewalk shall meet current Accessibility Standards.

14. Preconstruction root exploration is necessary prior to trenching adjacent to the oak tree and its root zone. This shall be done using non-invasive procedures, such as with a probe, by hand, using small tools or an air spade. If encountered roots should be handled in the following methods:
 - a. Roots less than two inches in diameter can be pruned cleanly with hand-pruners, loppers, or saws. The severed ends shall be covered with moist burlap or similar material.
 - b. Roots larger than two inches in diameter shall be preserved, protected, and bridged.
15. Prior to project final, compliance with all conditions of approval shall be demonstrated to the satisfaction of the Community Development Director. Upon evidence of non-compliance with conditions of approval or applicable municipal code provisions, the applicant shall remedy the non-compliance to the satisfaction of the Community Development Director or shall file an application for a permit amendment for Planning Commission consideration. Failure to remedy a non-compliance in a timely manner may result in permit revocation.
16. This permit shall expire 24 months from the date of issuance. The applicant shall have an approved building permit and construction underway before this date to prevent permit expiration. Applications for extension may be submitted by the applicant prior to expiration pursuant to Municipal Code section 17.81.160.
17. The planning and infrastructure review and approval are transferable with the title to the underlying property so that an approved project may be conveyed or assigned by the applicant to others without losing the approval. The permit cannot be transferred off the site on which the approval was granted.
18. Prior to building permit issuance, the applicant shall provide a signed hold harmless agreement form for any revocable encroachment permit included in the application.

FINDINGS

- A. The project, subject to the conditions imposed, secures the purposes of the Zoning Ordinance, General Plan, and Local Coastal Plan.**
Community Development Staff and the Planning Commission have reviewed the project. The proposed wall and privacy screens comply with the development standards of the R-1 District with Planning Commission approval. The project secures the purpose of the Zoning Ordinance, General Plan, and Local Coastal Plan.
- B. The project will maintain the character and integrity of the neighborhood.**
Community Development Staff and the Planning Commission have reviewed the application for an encroaching wall and privacy screens. The design of the new structures, with wood and stucco material, will fit in nicely with the existing neighborhood. The project will maintain the character and integrity of the neighborhood.
- C. This project is categorically exempt under Section 15301(e) of the California Environmental Quality Act and is subject to Section 753.5 of Title 14 of the California Code of Regulations.**
Section 15303(e) of the CEQA Guidelines exempts new accessory structures including garages, carports, patios, swimming pools, and fences. No adverse environmental impacts were discovered during review of the proposed project.

ATTACHMENTS:

1. 1591 Prospect Avenue - PC Staff Report - 12.05.2019
2. Revocable Encroachment Agreement Form
3. 1591 Prospect Avenue - Plan Set
4. Design Standards - Intersection Site Distance

Prepared By: Sean Sesanto



STAFF REPORT

TO: PLANNING COMMISSION
 FROM: COMMUNITY DEVELOPMENT
 DATE: DECEMBER 5, 2019
 SUBJECT: **1591 Prospect Avenue #19-0576 APN: 034-044-12**

Fence Permit with a location exception and Major Revocable Encroachment Permit for a wall in the public right of way located within the R-1 (Single-Family Residential) zoning district.

This project is in the Coastal Zone but does not require a Coastal Development Permit.

Environmental Determination: Categorical Exemption
 Property Owner: Eva Carpenter Trust, Attn: Nancy Yu
 Representative: Pedro Rosado, Filed: 10.24.19

APPLICANT PROPOSAL

The applicant is proposing to construct a wall and privacy screens located at 1591 Prospect Avenue within the R-1 (Single-Family Residential) zoning district. The application includes a Major Revocable Encroachment Permit and exception to fence location requirements.

BACKGROUND

The existing single-family residence at 1591 Prospect Avenue has a white picket fence, approximately 36 inches in height, along the front of the property facing Prospect Avenue, with a portion extending around the property line facing Lincoln Avenue. The public right of way area proposed for private improvements is currently an eleven-foot-wide dirt path with two plum trees and one large oak.

DISCUSSION

The applicant is proposing to replace the fence with a new plaster and concrete-block wall and three wooden horizontal board privacy screens. The new wall and two of the three privacy screens would encroach into the public right of way along Lincoln Avenue.

Fence Height

The proposed wall and privacy screens comply with the height requirements of the code. The proposed wall along Prospect Avenue and Lincoln Avenue is 30 to 42 inches in height. The proposed privacy screens along Lincoln Avenue are five feet, six inches in height and located behind the front line of the principal building. The property is located on a corner lot and is subject to line of sight requirements (Attachment 2). The proposed wall is located outside the required 20 foot clearance area from the intersection corner and decreases to 30 inches in height within 15 feet of the residence's driveway to comply with the line of sight requirements for corner lots.

Fence Location Exception

A portion of wall and one privacy screen, both considered fences under the zoning code, cross the property line along Lincoln Avenue and extend into the right of way. Capitola Municipal Code §17.54.020(A)(3) requires corner lot fences to be set back at least five feet from the property line on that side of the lot which has the greatest length along the street. Pursuant to CMC §17.54.020(B), the Planning Commission may approve alternative locations, heights, and materials for fences. The applicant is requesting a fence location exception to allow the fence in the side yard setback and public right of way.

Major Revocable Encroachment Permit

The application includes a major revocable encroachment permit for improvements in the public right of way. The encroachments include a wall along Prospect Avenue and a wall and three wooden privacy screens along Lincoln Avenue.

Pursuant to §12.56.060, the City may issue permits to allow certain improvements to be installed and maintained on public property by the adjacent private property owner. The Public Works director may approve minor improvements, such as fences under 42 inches in height, landscaping, and at-grade walkways, under a minor revocable encroachment permit. For improvements beyond those listed under the discretion of the Public Works Director, such as the proposed wall, a major revocable encroachment permit may be issued by the Planning Commission.

The Planning Commission must evaluate the following considerations when deciding whether or not to issue a major revocable encroachment permit:

1. The expense and difficulty that will be entailed in removing the improvement in the event of street widening;
Staff analysis: Within the revocable/hold harmless agreement, the owner must agree that the removal of the wall, when so ordered by the City, shall be at the owner's expense and not at the expense of the City.
2. Whether the proposed improvements are in conformity with the size, scale, and aesthetics of the surrounding neighborhood;
Staff analysis: The proposed wall uses similar materials and style to adjacent properties and is of similar size and scale within the surrounding neighborhood.
3. Preservation of views;
Staff analysis: The proposed wall and privacy screens are not expected to have a negative impact on the views to the public or neighboring properties.
4. Whether granting the permit would tend to result in the granting of a special privilege, in the sense that granting this permit would tend to preclude granting similar permits to neighboring property. If the benefit to the applicant and community is determined to exceed the detriment to the community, the permit shall be approved. The planning commission may, by providing reasonable notice to neighboring property owners, develop standards or criteria applicable to the entire block within which the property is located.
Staff analysis: The adjacent property at 1590 Lincoln Avenue has a wall that encroaches the public right-of-way to approximately the same distance from the road. The proposed encroachments do not extend into the right of way in front of adjacent properties. The proposal would not preclude granting a similar permit to neighboring properties.

Tree Removals

The applicant is proposing to remove two flowering plum trees within the public right of way in order to install the wall along Lincoln Avenue. Pursuant to §12.12.160(A), as part of any development application considered by it, the planning commission, may approve the removal of a non-heritage tree. With the removal of the two trees the property will retain 30 percent canopy coverage, meeting the post-removal tree canopy coverage goal of the Community Tree and Forest Management ordinance.

Public Works staff recommended that special consideration be given to the large oak tree when trenching for the wall. They recommended alternatives to using a backhoe near the tree, such as hand tools or an air spade. Small roots that will need to be removed must be sheared cleanly. If large roots are found in the excavation area an arborist should observe the work to prevent significant harm to the tree and root system.

After discussing Public Works concerns, the applicant did not have objections to staff including conditions requiring special management for the oak tree. A condition has been added to protect the health of the oak tree.

CEQA

Section 15303(e) of the CEQA Guidelines exempts new accessory structures. No adverse environmental impacts were discovered during review of the proposed project.

RECOMMENDATION

Staff recommends the Planning Commission review the application and approve project #19-0576 based on the following Conditions of Approval and Findings.

CONDITIONS OF APPROVAL

1. The project approval consists of a fence permit for the construction of a new wall and three privacy screens with a fence location exception for a fence in the required side setback area, a major revocable encroachment permit for the portions of the wall and privacy screens located within the public right of way, and the removal of two flowering plum trees in the public right of way. The proposed project is approved as indicated on the final plans reviewed and approved by the Planning Commission on December 5, 2019, except as modified through conditions imposed by the Planning Commission during the hearing.
2. Prior to construction, a building permit shall be secured for any new construction or modifications to structures authorized by this permit. Final building plans shall be consistent with the plans approved by the Planning Commission. All construction and site improvements shall be completed according to the approved plans
3. At time of submittal for building permit review, the Conditions of Approval must be printed in full on the cover sheet of the construction plans.
4. At time of submittal for building permit review, Public Works Standard Detail SMP STRM shall be printed in full and incorporated as a sheet into the construction plans. All construction shall be done in accordance with the Public Works Standard Detail BMP STRM.
5. Prior to making any changes to approved plans, modifications must be specifically requested and submitted in writing to the Community Development Department. Any

significant changes to the size or exterior appearance of the structure shall require Planning Commission approval.

6. Prior to issuance of building permit, a landscape plan shall be submitted and approved by the Community Development Department. The landscape plan can be produced by the property owner, landscape professional, or landscape architect. Landscape plans shall reflect the Planning Commission approval and shall identify type, size, and location of species and details of any proposed (but not required) irrigation systems.
7. Prior to issuance of building permit, all Planning fees associated with permit #19-0567 shall be paid in full.
8. Prior to issuance of building permits, a drainage plan, grading, sediment and erosion control plan, shall be submitted to the City and approved by Public Works. The plans shall be in compliance with the requirements specified in Capitola Municipal Code Chapter 13.16 Storm Water Pollution Prevention and Protection.
9. Prior to issuance of building permits, the applicant shall submit a stormwater management plan to the satisfaction of the Director of Public Works which implements all applicable Post Construction Requirements (PCRs) and Public Works Standard Details, including all standards relating to low impact development (LID).
10. Prior to any land disturbance, a pre-site inspection must be conducted by the grading official to verify compliance with the approved erosion and sediment control plan.
11. Prior to any work in the City road right of way, an encroachment permit shall be acquired by the contractor performing the work. No material or equipment storage may be placed in the road right-of-way.
12. During construction, any construction activity shall be subject to a construction noise curfew, except when otherwise specified in the building permit issued by the City. Construction noise shall be prohibited between the hours of nine p.m. and seven-thirty a.m. on weekdays. Construction noise shall be prohibited on weekends with the exception of Saturday work between nine a.m. and four p.m. or emergency work approved by the building official. §9.12.010B
13. Prior to a project final, all cracked or broken driveway approaches, curb, gutter, or sidewalk shall be replaced per the Public Works Standard Details and to the satisfaction of the Public Works Department. All replaced driveway approaches, curb, gutter or sidewalk shall meet current Accessibility Standards.
14. Preconstruction root exploration is necessary prior to trenching adjacent to the oak tree and its root zone. This shall be done using non-invasive procedures, such as with a probe, by hand, using small tools or an air spade. If encountered roots should be handled in the following methods:
 - a. Roots less than two inches in diameter, they can be pruned cleanly with hand-pruners, loppers, or saws. The severed ends shall be covered with moist burlap or similar material.
 - b. Roots larger than two inches in diameter shall be preserved, protected, and bridged.

15. Prior to project final, compliance with all conditions of approval shall be demonstrated to the satisfaction of the Community Development Director. Upon evidence of non-compliance with conditions of approval or applicable municipal code provisions, the applicant shall remedy the non-compliance to the satisfaction of the Community Development Director or shall file an application for a permit amendment for Planning Commission consideration. Failure to remedy a non-compliance in a timely manner may result in permit revocation.
16. This permit shall expire 24 months from the date of issuance. The applicant shall have an approved building permit and construction underway before this date to prevent permit expiration. Applications for extension may be submitted by the applicant prior to expiration pursuant to Municipal Code section 17.81.160.
17. The planning and infrastructure review and approval are transferable with the title to the underlying property so that an approved project may be conveyed or assigned by the applicant to others without losing the approval. The permit cannot be transferred off the site on which the approval was granted.

FINDINGS

- A. The project, subject to the conditions imposed, secures the purposes of the Zoning Ordinance, General Plan, and Local Coastal Plan.**
Community Development Staff and the Planning Commission have reviewed the project. The proposed wall and privacy screens comply with the development standards of the R-1 District with Planning Commission approval. The project secures the purpose of the Zoning Ordinance, General Plan, and Local Coastal Plan.
- B. The project will maintain the character and integrity of the neighborhood.**
Community Development Staff and the Planning Commission have reviewed the application for an encroaching wall and privacy screens. The design of the new structures, with wood and stucco material, will fit in nicely with the existing neighborhood. The project will maintain the character and integrity of the neighborhood.
- C. This project is categorically exempt under Section 15301(e) of the California Environmental Quality Act and is subject to Section 753.5 of Title 14 of the California Code of Regulations.**
Section 15303(e) of the CEQA Guidelines exempts new accessory structures including garages, carports, patios, swimming pools, and fences. No adverse environmental impacts were discovered during review of the proposed project.

ATTACHMENTS:

1. 1591 Prospect Avenue - Plan Set
2. Design Standards - Intersection Site Distance

Prepared By: Sean Sesanto

RECORDED AT THE REQUEST OF:

City of Capitola

WHEN RECORDED MAIL TO:

City of Capitola
420 Capitola Avenue
Capitola, CA 95010

THIS INSTRUMENT IS BEING RECORDED FOR THE BENEFIT OF THE CITY OF CAPITOLA NO RECORDING FEE IS REQUIRED PURSUANT TO GOVERNMENT CODE §27383

AGREEMENT REGARDING PRIVATE IMPROVEMENTS LOCATED ON PUBLIC RIGHT-OF-WAY

APN:
Address: Capitola

This Agreement is made pursuant to Section 12.56.060(a) of the Municipal Code. The permit is issued to _____, who, by signing below, warrants that they are the owners of the property commonly known as _____, APN: _____ and more particularly described in Exhibit "A" attached hereto. Pursuant to that section of the Municipal Code, permission has been granted for the placement of items upon the unimproved street right of way. The improvement may be viewed at the office of the City of Capitola Public Works Department, and is more particularly described as follows:

_____, within the City right-of-way, as approved by the Capitola Public Works Department on _____, as part of Encroachment Permit #_____.

PERMITTEE shall, at their expense, remove any improvements constructed by PERMITTEE or their predecessor in interest and PERMITTEE's rights under this agreement shall terminate within 45 days after written notice from the City. PERMITTEE agrees that in the event of its failure to remove any such improvements within the time specified, the same may be removed and the City's property restored by the City and the cost thereof made a lien against PERMITTEE PROPERTY described in Exhibit A, pursuant to the provisions of Chapter 12.56 of the Capitola Municipal Code.

PERMITTEE, in consideration to the issuance of this agreement, agrees to indemnify, defend (with counsel selected by the City) and hold harmless the City of Capitola, its officers, agents, and employees from any liability of any nature whatsoever caused in whole or in part, by reason of or in any manner connected with any and all the operations, structures or conditions authorized or permitted by this agreement.

PERMITTEE is subject to and bound by all of the provisions of Capitola Municipal Code Chapter 12.56.

PERMITTEE hereby accepts this agreement subject to all of the conditions set forth herein and agrees that all of the said conditions shall be binding on PERMITTEE, co-owners, heirs, assigns, transferees and successors in interest of every nature. This agreement shall expire if construction of improvements as set forth above does not commence within 90 days from the date PERMITTER approves this agreement.

Attachment: Revocable Encroachment Agreement Form (2784 : 1591 Prospect Avenue)

None of the City's rights, not Permittee's obligations, can be waived without specific written agreement authorized by the City's Director of Public Works.

The person signing below as of for PERMITTEE hereby warrants and declares under penalty of perjury that he has the authority and ownership interest necessary to encumber the property as herein provided.

So Agreed:

PERMITTER – CITY OF CAPITOLA Benjamin Goldstein, City Manager	Date
--	------

insert property owner name	Date
----------------------------	------

insert property owner name	Date
----------------------------	------

APPROVED AS TO DESCRIPTION:

Steven E. Jesberg City Engineer	Date
------------------------------------	------

APPROVED AS TO FORM:

Samantha Zutler City Attorney	Date
----------------------------------	------

Attachment: Revocable Encroachment Agreement Form (2784 : 1591 Prospect Avenue)

EXHIBIT "A"
PROPERTY DESCRIPTION

The land referred to herein is described as follows:

SITUATE in the City of Capitola, County of Santa Cruz, State of California

BEING A PORTION OF

APN:

Attachment: Revocable Encroachment Agreement Form (2784 : 1591 Prospect Avenue)

A notary public or other officer completing this certificate verifies only the identity of the individual who signed the document to which this certificate is attached, and not the truthfulness, accuracy, or validity of the document.

CALIFORNIA ALL-PURPOSE ACKNOWLEDGMENT

State of California)
County of Santa Cruz)

On _____, before me, _____
(insert Name and title of the officer)

personally appeared _____
who proved to me on the basis of satisfactory evidence to be the person(s) whose name(s) is/are subscribed to the within instrument and acknowledged to me that he/she/they executed the same in his/her/their authorized capacity(ies), and that by his/her/their signature(s) on the instrument the person(s), or entity upon behalf of which the person(s) acted, executed the instrument.

I certify under PENALTY OF PERJURY under the laws of the State of California that the foregoing paragraph is true and correct.

WITNESS my hand and official seal.

Signature _____ (Seal)

Attachment: Revocable Encroachment Agreement Form (2784 : 1591 Prospect Avenue)

A notary public or other officer completing this certificate verifies only the identity of the individual who signed the document to which this certificate is attached, and not the truthfulness, accuracy, or validity of the document.

CALIFORNIA ALL-PURPOSE ACKNOWLEDGMENT

State of California)
County of Santa Cruz)

On _____, before me, _____
(insert Name and title of the officer)

personally appeared _____
who proved to me on the basis of satisfactory evidence to be the person(s) whose name(s) is/are subscribed to the within instrument and acknowledged to me that he/she/they executed the same in his/her/their authorized capacity(ies), and that by his/her/their signature(s) on the instrument the person(s), or entity upon behalf of which the person(s) acted, executed the instrument.

I certify under PENALTY OF PERJURY under the laws of the State of California that the foregoing paragraph is true and correct.

WITNESS my hand and official seal.

Signature _____ (Seal)

Attachment: Revocable Encroachment Agreement Form (2784 : 1591 Prospect Avenue)

Proposed Landscape Plan For

1501 Prospect Ave
Capitola, CA

Owner:
Eva Carpenter Trust
Attn: Nancy Yu & Karen Ivanick
15 Ross Court
Capitola, CA 95006
Tel: (925) 575-0172

Assessor's Parcel Number: 034-044-12-000
Property Address: 1501 Prospect Ave
Capitola, CA

Zoning: R1
Lot Size: 2,063 s.f.

Scope of Work: Construct an outdoor privacy wall & wood privacy screens, add an outdoor patio, add outlets, and exterior lights.

Site Coverage:
Existing: 757 s.f.
House (1st floor) 115 s.f.
Driveway & walk 151 s.f.
Sub-Total = 1023 s.f. (49.6%)
Proposed patio & stepping stones 1287 s.f.
Total Coverage = 2310 s.f. (112.4%)

Floor Area:
Existing: 507 s.f.
1st Floor = 175 s.f.
2nd Floor = 175 s.f.
Garage = 200 s.f.

Drawings Prepared By:
PEDRO F. ROSADO, Architect
8755 Colter Road, Promenade, CA 93907
Ph: (831) 663-0966

Codes Applicable:
2018 CEC (Cal Electric Code)
2018 CBC (Cal Building Code)
2018 CMC (Cal Mechanical Code)
2018 CRC (Cal Residential Code)
2018 CDB (Cal Green Bldg. Code)
2018 CDB (Cal Green Bldg. Code)
The California Building Code of the CBCB will be implemented.

Project Data: (R-3) U
Type V-8 Construction, non-sprinklered
One Story
Square Footage Summary: See FF Area Above

SHEET INDEX
A1 Title, Location Map, Site Plan
A2 Foundation
A3 Landscape Plan & Drainage

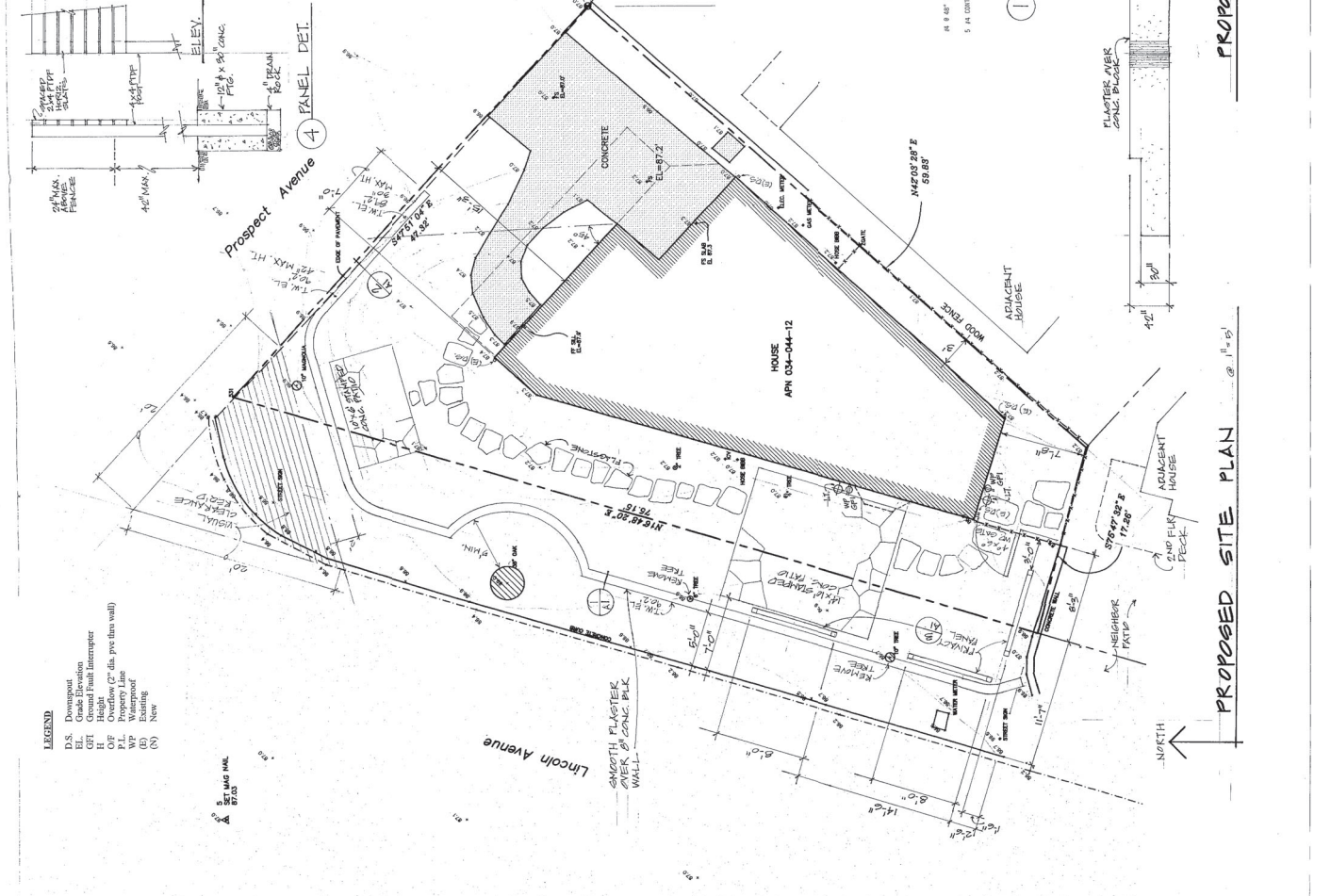
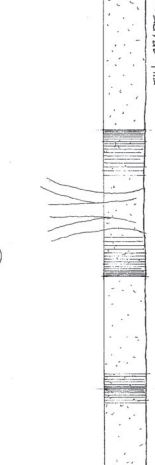
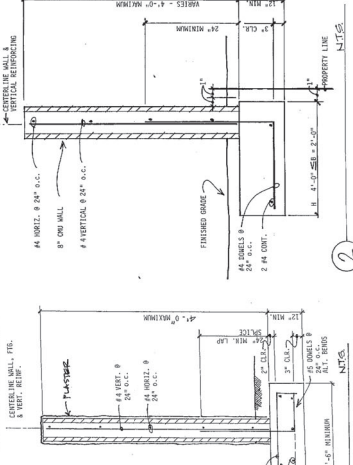
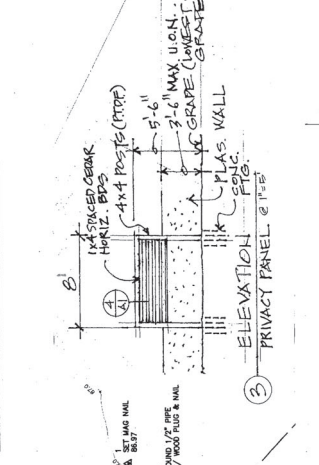

LEGEND
D.S. Downspout
E.I. Elevation
G.F.T. Ground Fault Interrupter
H.H. Height
H.L. Horizontal
P.L. Property Line
W.P. Waterproof
W.S. Wall
(N) Note

PROPOSED FENCE ELEVATION @ 1/8" = 1'-0"
PROPOSED SITE PLAN @ 1/8" = 5'

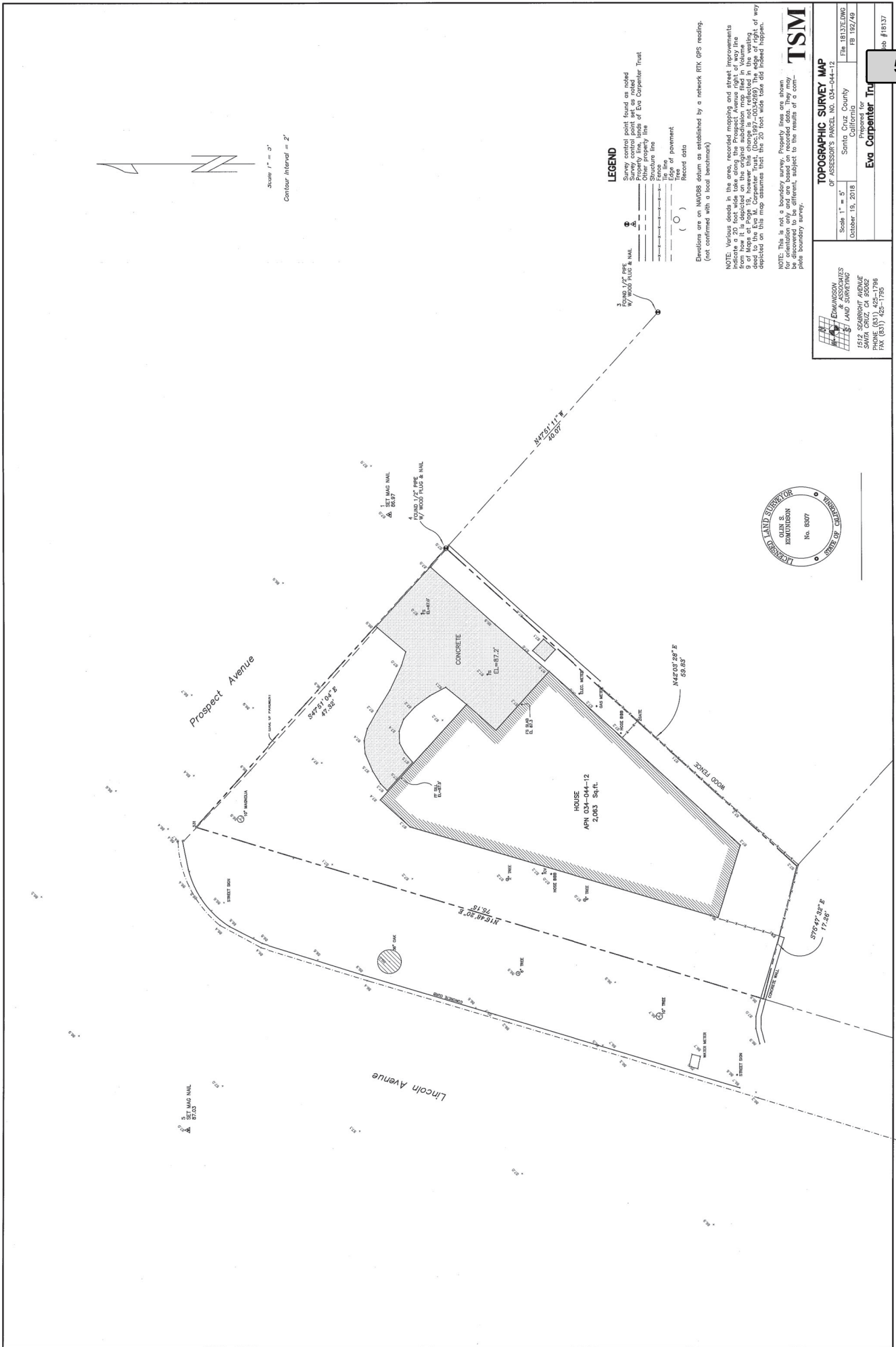

Scale 1" = 5'
Contour Interval = 2'

- LEGEND**
- Survey control point found as noted
 - Property line, lands of Eva Carpenter Trust
 - Structure line
 - Edge of pavement
 - Record data

Contours are an MANGRO datum as established by a network RTK GPS reading.
(not confirmed with a local benchmark)

NOTE: Various dead in the area, recorded mapping and street improvements indicate a 20-foot wide take along the Prospect Avenue right of way line. This change is not reflected in the existing map. The change is reflected in the existing map of Page 19, however this change is not reflected in the existing map. The change is reflected in the existing map of Page 19, however this change is not reflected in the existing map. The change is reflected in the existing map of Page 19, however this change is not reflected in the existing map.

NOTE: This is not a boundary survey. Property lines are shown for orientation only and are based on recorded data. They may be different, subject to the results of a complete boundary survey.

TSM

TOPOGRAPHIC SURVEY MAP OF ASSESSOR'S PARCEL NO. 034-04-12	
Scale 1" = 5'	City Santa Cruz County California
October 19, 2018	FB 18137EDWG FB 192749
Surveyed for Eva Carpenter Trust	
1517 SERRAVALLO AVENUE SANTA CRUZ, CA 95062 PHONE (531) 425-1796 FAX (531) 425-1795	

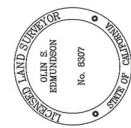

5.A.3

Attachment: 1591 Prospect Avenue - Plan Set (2784 : 1591 Prospect Avenue)

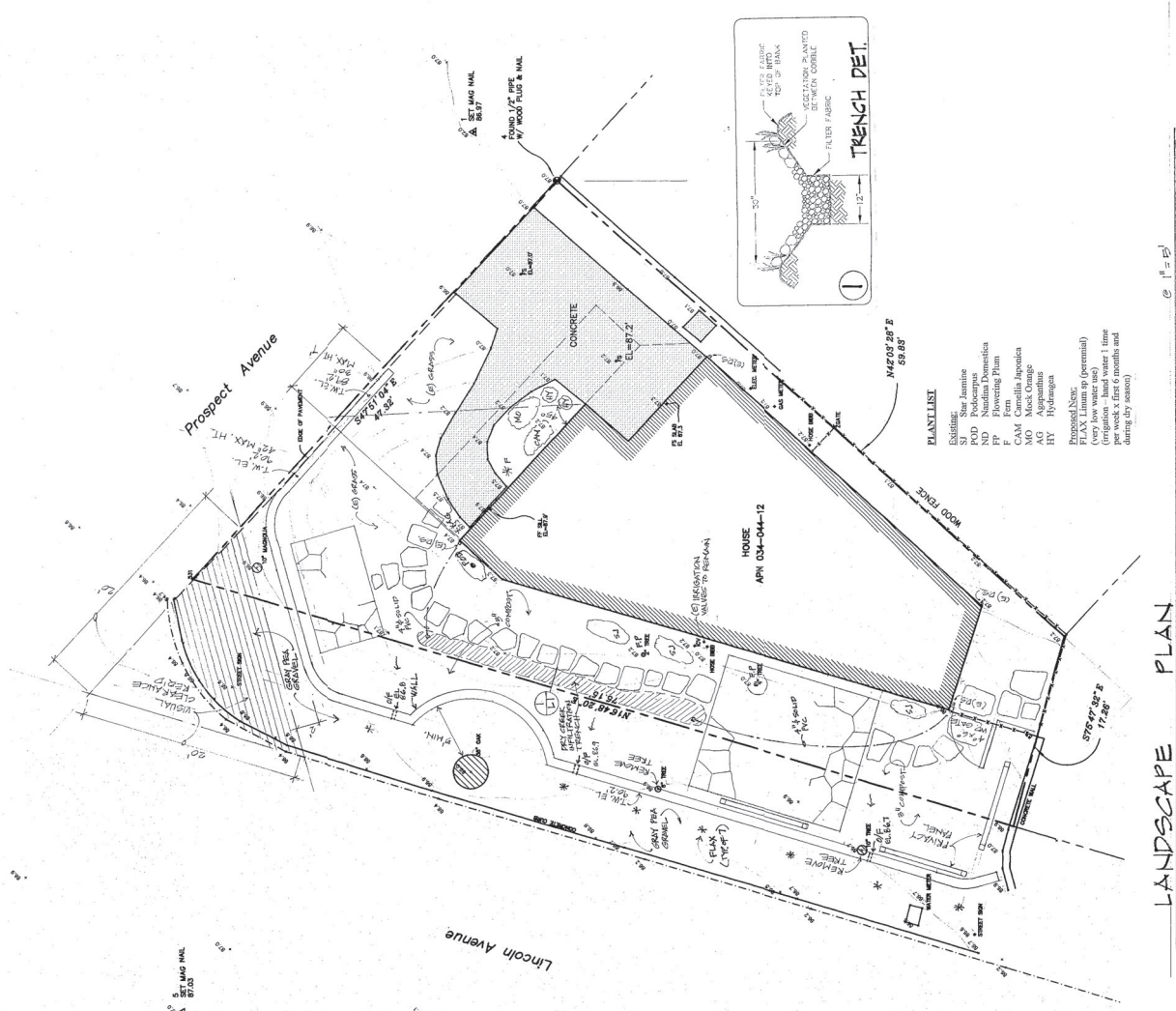

Attachment: 1591 Prospect Avenue - Plan Set (2784 : 1591 Prospect Avenue)

LANDSCAPE PLAN

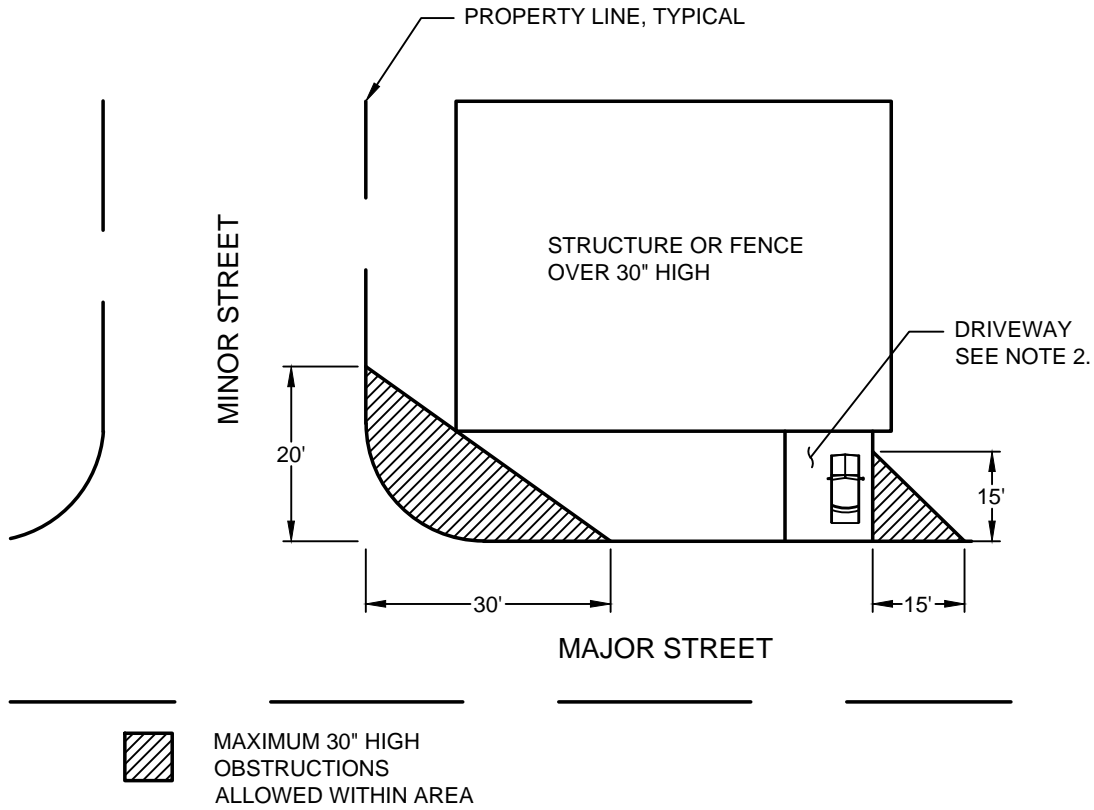

NOTES:

1. MAJOR STREET ADT > 2000; MINOR STREET ADT < 2000.
2. DRIVEWAY SHALL BE LOCATED AS FAR AS PRACTICAL FROM INTERSECTION.
3. SITE DISTANCE TRIANGLE TYPICAL EACH SIDE OF DRIVEWAY.
4. ALTERNATIVE ANALYSIS ALLOWED PER TOPIC 405 CALTRANS HIGHWAY DESIGN MANUAL 4TH EDITION.

Attachment: Design Standards - Intersection Site Distance (2784 : 1591 Prospect Avenue)

NOT TO SCALE		STANDARD DRAWINGS FOR INTERSECTION SITE DISTANCE	DRAWN: 1/15	REV:
DRAWN BY: B&W			DRAWING No.	
CHECKED BY: JFR		STEVEN JESBERG, PUBLIC WORKS DIRECTOR	Packet Pg. 39	



STAFF REPORT

TO: PLANNING COMMISSION

FROM: COMMUNITY DEVELOPMENT

DATE: JANUARY 16, 2020

SUBJECT: **Brommer Street Improvements** **#19-0740** **APN: N/A**

Coastal Development Permit for roadway improvements on Brommer Street between 41st Avenue and 38th Avenue in the C-C, RM-H, PF-F, and PD Zoning Districts. The improvements include a new sidewalk on the north side of Brommer Street, new striping with Class 2 bike lanes, and roadway repaving. This project is in the Coastal Zone and requires a Coastal Development Permit which is not appealable to the California Coastal Commission after all possible appeals are exhausted through the City.

Environmental Determination: Categorical Exemption
 Property Owner: City of Capitola
 Representative: Kailash Mozumder, Filed: 12.17.2019

APPLICANT PROPOSAL

The City of Capitola is applying for a Coastal Development Permit for roadway and sidewalk improvements on Brommer Street in the Community Commercial (C-C), Multi-Family Residential High Density (RM-H), Public Facilities (PF-F), and Planned Development (PD) Zoning Districts. The improvements include a new sidewalk on the north side of Brommer Street, new striping with Class 2 bike lanes, and roadway repaving from 41st Avenue to the City limits on Brommer Street.

BACKGROUND

The Brommer Street improvement project has been in the Capitola Improvement Program (CIP) since 2012. The current project limits were initially established in 2012, but the final design was not completed until funding was secured in the form of a Measure D allocation and a Santa Cruz Regional Transportation Commission Regional Surface Transportation Program Exchange (RSTPX) allocation in November 2018.

DISCUSSION

The City is proposing a complete repaving and restriping of the Brommer Street roadway, driveway improvements, and a new sidewalk on the north side to improve access for vehicles, bicycles, and pedestrians. Detailed plans of the improvements are included (Attachment 1). A coastal development permit is required for the project.

Coastal Development Permit

The proposed project is located in the Coastal Exclusion Zone A non-appealable coastal area, as identified in the Capitola “Permit and Appeal Jurisdiction” Map. Capitola’s Local Coastal Plan requires the issuance of a coastal permit because it does not qualify for the following exemption:

“§17.46.050.B(3)(d): repair or maintenance activities that do not result in an addition to, or enlargement or expansion of, the object of those repair or maintenance activities, not including extraordinary methods of repair and maintenance per subsection (A)(3) of this section”

The City is proposing a new sidewalk on the north side of Brommer Street to improve safety and access for pedestrians. Public Works staff has been coordinating this work with the property owners affected by the new sidewalk. The street will be repaved, and new striping will modify the current lane layout to improve the turning radius from 41st Avenue on Brommer. Also, new striping of the bike lanes will clearly delineate the Class 2 lanes. The proposed improvements will increase public access to the coast and recreational opportunities. The project complies with the required findings of a coastal development permit.

CEQA

Section 15332 of the CEQA Guidelines exempts projects characterized as in-fill development. Specifically, 15332 exempts projects meeting the following conditions:

- (a) The project is consistent with the applicable general plan designation and all applicable general plan policies as well as with applicable zoning designation and regulations.
- (b) The proposed development occurs within city limits on a project site of no more than five acres substantially surrounded by urban uses.
- (c) The project site has no value as habitat for endangered, rare, or threatened species.
- (d) Approval of the project would not result in any significant effects relating to traffic, noise, air quality, or water quality.
- (e) The site can be adequately served by all required utilities and public services.

The project meets all of these criteria, and no adverse environmental impacts were discovered during review of the proposed project.

RECOMMENDATION

Staff recommends that the Planning Commission **approve** application #19-0740 based on the following Conditions and Findings for Approval.

CONDITIONS OF APPROVAL

1. The project approval consists of a coastal development permit for roadway and sidewalk improvements on Brommer Street between 41st Avenue and 38th Avenue in the C-C, RM-H, PF-F, and PD Zoning Districts. The improvements include a new sidewalk on the north side of Brommer Street, new striping with Class 2 bike lanes, and roadway repaving. The proposed project is approved as indicated on the final plans reviewed and approved by the Planning Commission on January 16, 2020, except as modified through conditions imposed by the Planning Commission during the hearing.
2. During construction, any construction activity shall be subject to a construction noise curfew, except when otherwise specified in the building permit issued by the City. Construction hours shall be limited between the hours of 8:00 a.m. and 5:00 p.m. on weekdays. Construction shall be prohibited on weekends or legal holidays except in case of an emergency work approved by the Public Works Director.

FINDINGS

A. The application, subject to the conditions imposed, secures the purposes of the Zoning Ordinance, General Plan, and Local Coastal Plan.

Community Development Department Staff and the Planning Commission have reviewed the project. The coastal development permit for the Brommer Street sidewalk and roadway improvements conform to the requirements of the Local Coastal Program and conditions of approval have been included to carry out the objectives of the Zoning Ordinance, General Plan, and Local Coastal Plan.

B. This project is categorically exempt under Section 15332 of the California Environmental Quality Act and is not subject to Section 753.5 of Title 14 of the California Code of Regulations.

Section 15332 of the CEQA Guidelines exempts in-fill development projects. Specifically, 15332 exempts projects meeting the following conditions:

- (a) The project is consistent with the applicable general plan designation and all applicable general plan policies as well as with applicable zoning designation and regulations.
- (b) The proposed development occurs within city limits on a project site of no more than five acres substantially surrounded by urban uses.
- (c) The project site has no value as habitat for endangered, rare, or threatened species.
- (d) Approval of the project would not result in any significant effects relating to traffic, noise, air quality, or water quality.
- (e) The site can be adequately served by all required utilities and public services.

The project meets all of these criteria, and no adverse environmental impacts were discovered during review of the proposed project.

COASTAL FINDINGS

D. Findings Required.

1. **A coastal permit shall be granted only upon adoption of specific written factual findings supporting the conclusion that the proposed development conforms to the certified Local Coastal Program, including, but not limited to:**
 - a. A statement of the individual and cumulative burdens imposed on public access and recreation opportunities based on applicable factors identified pursuant to subsection (D)(2) of this section. The type of affected public access and recreation opportunities shall be clearly described;
 - b. An analysis based on applicable factors identified in subsection (D)(2) of this section of the necessity for requiring public access conditions to find the project consistent with the public access provisions of the Coastal Act;
 - c. A description of the legitimate governmental interest furthered by any access conditioned required;
 - d. An explanation of how imposition of an access dedication requirement alleviates the access burdens identified.
 - The proposed development conforms to the City's certified Local Coastal Plan (LCP). The specific, factual findings, as per CMC Section 17.46.090(D) are as follows:

- 2. Require Project-Specific Findings. In determining any requirement for public access, including the type of access and character of use, the city shall evaluate and document in written findings the factors identified in subsections (D)(2)(a) through (e), to the extent applicable. The findings shall explain the basis for the conclusions and decisions of the city and shall be supported by substantial evidence in the record. If an access dedication is required as a condition of approval, the findings shall explain how the adverse effects which have been identified will be alleviated or mitigated by the dedication. As used in this section, “cumulative effect” means the effect of the individual project in combination with the effects of past projects, other current projects, and probable future projects, including development allowed under applicable planning and zoning.**
- a. **Project Effects on Demand for Access and Recreation.** Identification of existing and open public access and coastal recreation areas and facilities in the regional and local vicinity of the development. Analysis of the project’s effects upon existing public access and recreation opportunities. Analysis of the project’s cumulative effects upon the use and capacity of the identified access and recreation opportunities, including public tidelands and beach resources, and upon the capacity of major coastal roads from subdivision, intensification or cumulative buildout. Projection for the anticipated demand and need for increased coastal access and recreation opportunities for the public. Analysis of the contribution of the project’s cumulative effects to any such projected increase. Description of the physical characteristics of the site and its proximity to the sea, tideland viewing points, upland recreation areas, and trail linkages to tidelands or recreation areas. Analysis of the importance and potential of the site, because of its location or other characteristics, for creating, preserving or enhancing public access to tidelands or public recreation opportunities;
- The proposed project is located along Brommer Street between 41st Avenue and 38th Avenue. The project is not located in an area with coastal access. The project will, however, increase the public’s access to public trails and locations with beach access.
- b. **Shoreline Processes.** Description of the existing shoreline conditions, including beach profile, accessibility and usability of the beach, history of erosion or accretion, character and sources of sand, wave and sand movement, presence of shoreline protective structures, location of the line of mean high tide during the season when the beach is at its narrowest (generally during the late winter) and the proximity of that line to existing structures, and any other factors which substantially characterize or affect the shoreline processes at the site. Identification of anticipated changes to shoreline processes at the site. Identification of anticipated changes to shoreline processes and beach profile unrelated to the proposed development. Description and analysis of any reasonably likely changes, attributable to the primary and cumulative effects of the project, to: wave and sand movement affecting beaches in the vicinity of the project; the profile of the beach; the character, extent, accessibility and usability of the beach; and any other factors which characterize or affect beaches in the vicinity. Analysis of the effect of any identified changes of the project, alone or in combination with other anticipated changes, will have upon the ability of the public to use public tidelands and shoreline recreation areas;
- The proposed project is located along Brommer Street between 41st Avenue and 38th Avenue. No portion of the project is located along the shoreline or beach.

- c. **Historic Public Use.** Evidence of use of the site by members of the general public for a continuous five-year period (such use may be seasonal). Evidence of the type and character of use made by the public (vertical, lateral, blufftop, etc., and for passive and/or active recreational use, etc.). Identification of any agency (or person) who has maintained and/or improved the area subject to historic public use and the nature of the maintenance performed and improvements made. Identification of the record owner of the area historically used by the public and any attempts by the owner to prohibit public use of the area, including the success or failure of those attempts. Description of the potential for adverse impact on public use of the area from the proposed development (including but not limited to, creation of physical or psychological impediments to public use);
- There is a history of public use in the proposed project area. The project involves the public right-of-way for Brommer Street, which currently has a public street and bike lanes. The project is designed to increase the safety and accessibility of public streets and sidewalks along Brommer Street.
- d. **Physical Obstructions.** Description of any physical aspects of the development which block or impede the ability of the public to get to or along the tidelands, public recreation areas, or other public coastal resources or to see the shoreline;
- The proposed project is located in the public right of way along Brommer Street. The project will not block or impede the ability of the public to get to or along the tidelands, public recreation areas, or views to the shoreline. The project will increase the ability of the public to get to those areas.
- e. **Other Adverse Impacts on Access and Recreation.** Description of the development's physical proximity and relationship to the shoreline and any public recreation area. Analysis of the extent of which buildings, walls, signs, streets or other aspects of the development, individually or cumulatively, are likely to diminish the public's use of tidelands or lands committed to public recreation. Description of any alteration of the aesthetic, visual or recreational value of public use areas, and of any diminution of the quality or amount of recreational use of public lands which may be attributable to the individual or cumulative effects of the development.
- The proposed project is located in the public right of way along Brommer Street and will increase the public's access to coastal areas and recreational opportunities. The project does not diminish the public's use of tidelands or lands committed to public recreation nor alter the aesthetic, visual, or recreational value of public use areas.
- 3. Required Findings for Public Access Exceptions. Any determination that one of the exceptions of subsection (F)(2) applies to a development shall be supported by written findings of fact, analysis and conclusions which address all of the following:**
- a. The type of access potentially applicable to the site involved (vertical, lateral, bluff top, etc.) and its location in relation to the fragile coastal resource to be protected, the agricultural use, the public safety concern, or the military facility which is the basis for the exception, as applicable;

- b. Unavailability of any mitigating measures to manage the type, character, intensity, hours, season or location of such use so that agricultural resources, fragile coastal resources, public safety, or military security, as applicable, are protected;
 - c. Ability of the public, through another reasonable means, to reach the same area of public tidelands as would be made accessible by an accessway on the subject land.
 - The project is not requesting a Public Access Exception, therefore these findings do not apply.
- 4. Findings for Management Plan Conditions. Written findings in support of a condition requiring a management plan for regulating the time and manner or character of public access use must address the following factors, as applicable:**
- a. Identification and protection of specific habitat values including the reasons supporting the conclusions that such values must be protected by limiting the hours, seasons, or character of public use;
 - The project is located in an urban area without sensitive habitat areas.
 - b. Topographic constraints of the development site;
 - The project is in the public right of way along Brommer Street with no significant topographic constraints.
 - c. Recreational needs of the public;
 - The project does not impact the recreational needs of the public.
 - d. Rights of privacy of the landowner which could not be mitigated by setting the project back from the access way or otherwise conditioning the development;
 - e. The requirements of the possible accepting agency, if an offer of dedication is the mechanism for securing public access;
 - f. Feasibility of adequate setbacks, fencing, landscaping, and other methods as part of a management plan to regulate public use.
- 5. Project complies with public access requirements, including submittal of appropriate legal documents to ensure the right of public access whenever, and as, required by the certified land use plan and Section 17.46.010 (coastal access requirements);**
- No legal documents to ensure public access rights are required for the proposed project.
- 6. Project complies with visitor-serving and recreational use policies;**

SEC. 30222

The use of private lands suitable for visitor-serving commercial recreational facilities designed to enhance public opportunities for coastal recreation shall have priority over private residential, general industrial, or general commercial development, but not over agriculture or coastal-dependent industry.

- The project involves a new sidewalk on the north side of Brommer Street and road repaving and restriping in the public right of way along Brommer Street. The new striping will include Class 2 bike lines.

SEC. 30223

Upland areas necessary to support coastal recreational uses shall be reserved for such uses, where feasible.

- The project involves a new sidewalk on the north side and road repaving and restriping in the public right of way along Brommer Street.

c) Visitor-serving facilities that cannot be feasibly located in existing developed areas shall be located in existing isolated developments or at selected points of attraction for visitors.

- The project involves a new sidewalk on the north side and road repaving and restriping in the public right of way along Brommer Street.

7. Project complies with applicable standards and requirements for provision of public and private parking, pedestrian access, alternate means of transportation and/or traffic improvements;

- The project involves the construction of a new sidewalk on the north side of Brommer Street and road repaving and restriping. The project complies with applicable standards and requirements for provision for parking, pedestrian access, alternate means of transportation, and/or traffic improvements.

8. Review of project design, site plan, signing, lighting, landscaping, etc., by the city's architectural and site review committee, and compliance with adopted design guidelines and standards, and review committee recommendations;

- The project complies with the design guidelines and standards established by the Municipal Code.

9. Project complies with LCP policies regarding protection of public landmarks, protection or provision of public views; and shall not block or detract from public views to and along Capitola's shoreline;

- The project will not negatively impact public landmarks and/or public views. The project will not block or detract from public views to and along Capitola's shoreline.

10. Demonstrated availability and adequacy of water and sewer services;

- The project is located in the public right of way along Brommer Street.

11. Provisions of minimum water flow rates and fire response times;

- The project is located 1.2 miles from the Central Fire Protection District Live Oak Station. Water is available at the location.

12. Project complies with water and energy conservation standards;

- The project is for a new sidewalk on the north side of Brommer Street and road repaving and restriping. The GHG emissions for the project are projected at less than significant impact.
- 13. Provision of park dedication, school impact, and other fees as may be required;**
- The project will be required to pay appropriate fees prior to building permit issuance.
- 14. Project complies with coastal housing policies, and applicable ordinances including condominium conversion and mobile home ordinances;**
- The project does not involve a condo conversion or mobile homes.
- 15. Project complies with natural resource, habitat, and archaeological protection policies;**
- Conditions of approval have been included to ensure compliance with established policies.
- 16. Project complies with Monarch butterfly habitat protection policies;**
- The project is outside of any identified sensitive habitats, specifically areas where Monarch Butterflies have been encountered, identified, and documented.
- 17. Project provides drainage and erosion and control measures to protect marine, stream, and wetland water quality from urban runoff and erosion;**
- Conditions of approval have been included to ensure compliance with applicable erosion control measures.
- 18. Geologic/engineering reports have been prepared by qualified professional for projects in seismic areas, geologically unstable areas, or coastal bluffs, and project complies with hazard protection policies including provision of appropriate setbacks and mitigation measures;**
- Geologic/engineering reports have been prepared by qualified professionals for this project. Conditions of approval have been included to ensure the project applicant shall comply with all applicable requirements of the most recent version of the California Building Standards Code.
- 19. All other geological, flood and fire hazards are accounted for and mitigated in the project design;**
- Conditions of approval have been included to ensure the project complies with geological, flood, and fire hazards and are accounted for and will be mitigated in the project design.
- 20. Project complies with shoreline structure policies;**
- The proposed project is not located along a shoreline.

21. The uses proposed are consistent with the permitted or conditional uses of the zoning district in which the project is located;

- Not applicable.

22. Conformance to requirements of all other city ordinances, zoning requirements, and project review procedures; and

- The project conforms to the requirements of all city ordinances, zoning requirements, and project development review and development procedures.

23. Project complies with the Capitola parking permit program as follows:

- a. The village area preferential parking program areas and conditions as established in Resolution No. 2596 and no permit parking of any kind shall be allowed on Capitola Avenue.
 - b. The neighborhood preferential parking program areas are as established in Resolution Numbers 2433 and 2510.
 - c. The village area preferential parking program shall be limited to three hundred fifty permits.
 - d. Neighborhood permit areas are only in force when the shuttle bus is operating except that:
 - i. The Fanmar area (Resolution No. 2436) program may operate year-round, twenty-four hours a day on weekends,
 - ii. The Burlingame, Cliff Avenue/Grand Avenue area (Resolution No. 2435) have year-round, twenty-four hour per day “no public parking.”
 - e. Except as specifically allowed under the village parking program, no preferential residential parking may be allowed in the Cliff Drive parking areas.
 - f. Six Depot Hill twenty-four minute “Vista” parking spaces (Resolution No. 2510) shall be provided as corrected in Exhibit A attached to the ordinance codified in this section and found on file in the office of the city clerk.
 - g. A limit of fifty permits for the Pacific Cove parking lot may be issued to village permit holders and transient occupancy permit holders.
 - h. No additional development in the village that intensifies use and requires additional parking shall be permitted. Changes in use that do not result in additional parking demand can be allowed and exceptions for onsite parking as allowed in the land use plan can be made.
- The project site is not located within the area of the Capitola parking permit program.

ATTACHMENTS:

1. Brommer Street Improvements - Plan Set - Letter

Prepared By: Sean Sesanto

PROJECT DESCRIPTION

CONSTRUCT COMPLETE STREET IMPROVEMENTS ON BROMMER STREET FROM CITY OF CAPITOLA WESTERN CITY LIMITS TO 41ST AVENUE TO IMPROVE ACCESS TO THE PROJECT SITE AND TO RECONSTRUCT AND IMPROVE BROMMER STREET RECONSTRUCTING THE BROMMER STREET ROADWAY AND CONSTRUCTING A SIDEWALK ON THE NORTH SIDE.

BASIS OF BEARINGS AND ELEVATIONS

THE BASIS OF BEARINGS FOR THIS SURVEY IS THE CALCULATED BEARING BETWEEN THE ROUND RAILROAD STREET, A THE INTERSECTION OF BLUE AVENUE AND BROMMER STREET, AND THE INTERSECTION OF BROMMER STREET AND THE NORTHWEST CORNER OF LOT 9, AS SHOWN ON RECORD OF SURVEY OF A SANITATION DISTRICT RECORDED IN VOLUME 47 OF MAPS AT PAGE 10 & 11, BEARING = 118°56'57" W

THE BASIS OF ELEVATIONS FOR THIS MAP IS THE COUNTY OF SANTA CRUZ CROSSING SIGNAL AT THE NORTHWEST CORNER OF INTERSECTION OF RAILROAD AND 41ST AVENUE.

ELEVATION = 66.60 (NAD83)
CONTOUR INTERVAL = 1 FOOT
DIMENSIONS ARE SHOWN IN FEET AND DECIMALS THEREOF

SCHEDULE A

STA 15+50 TO 22+48
38TH AVENUE TO 41ST AVENUE: IMPROVEMENTS INCLUDE PAVEMENT RECONSTRUCTION, CURB, GUTTER, SIDEWALK, DRIVEWAY IMPROVEMENTS, SIGNING AND STRIPING ALONG BROMMER STREET.

SCHEDULE B

STA 12+25 TO 15+00
CITY OF CAPITOLA CITY LIMITS TO 38TH AVENUE: IMPROVEMENTS INCLUDE PAVEMENT RECONSTRUCTION, SIGNING AND STRIPING ALONG BROMMER STREET.

ACCEPTANCE OF PLANS

THE CITY OF CAPITOLA HEREBY ACCEPTS THESE PLANS FOR CONSTRUCTION AS BEING IN GENERAL COMPLIANCE WITH PLANS PREPARATION REQUIREMENTS OF THIS GOVERNMENT, RESPONSIBILITY FOR THE COMPLETENESS AND ACCURACY OF THESE PLANS REMAINS WITH THE ENGINEER AND HIS ASSOCIATES, INC. AND ENGINEERING FIRM OF RECORD.

Steve Jesberg
STEVE JESBERG P.E.
DIRECTOR OF PUBLIC WORKS
CITY ENGINEER
CITY OF CAPITOLA
DATE 11/22/2019



BROMMER STREET COMPLETE STREET IMPROVEMENTS

SANTA CRUZ COUNTY
CAPITOLA, CALIFORNIA

TO BE SUPPLEMENTED BY THE PROJECT SPECIFICATIONS - CITY OF CAPITOLA STANDARD DRAWINGS, CALTRANS STANDARD PLANS DATED OCTOBER 2018, AND CALIFORNIA MUTCD REV 4 DATED MARCH 2019.

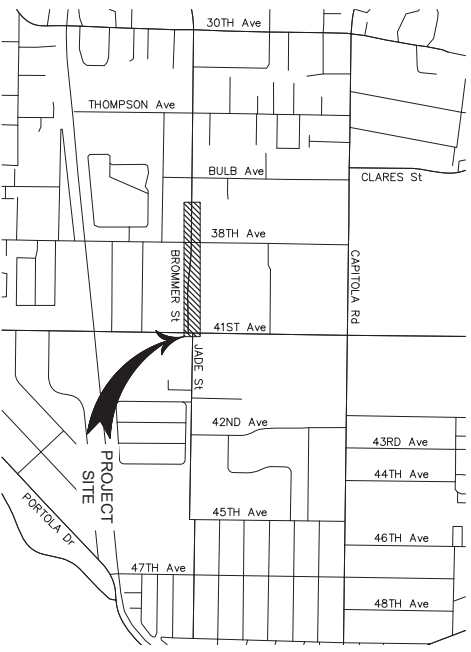

SHEET INDEX	
SHEET NO	DRAWING NO
1	CV-1
2	X-1
3	HC-1
4-6	L-1 TO L-3
7	P-1
8-10	CD-1 TO CD-3
11-13	SS-1 TO SS-3

NO.	REVISIONS	DATE	BY

Kimley-Horn
© 2019 KIMLEY-HORN AND ASSOCIATES, INC.
100 WEST 24th STREET
PHONE: 866-400-4139
WWW.KIMLEY-HORN.COM

**BROMMER COMPLETE STREET
IMPROVEMENTS**
PREPARED FOR
CITY OF CAPITOLA
SANTA CRUZ COUNTY



COVER SHEET
SHEET NO. 1
OF 13 SHEETS
CV-1

GENERAL PROJECT NOTES

1. ALL IMPROVEMENTS SHALL BE CONSTRUCTED IN ACCORDANCE WITH THESE PLANS AND THE PROJECT SPECIFICATIONS.
2. CONTRACTOR SHALL POSSESS THE CLASS (OR CLASSES) OF LICENSE AS SPECIFIED IN THE "NOTICE TO CONTRACTORS"
3. EXACT FIELD LOCATION FOR NEW IMPROVEMENTS SHALL BE APPROVED BY THE ENGINEER BEFORE CONSTRUCTION.
4. VERIFICATION OF EXISTING CONDITIONS: CONTRACTOR SHALL VERIFY ALL EXISTING CONDITIONS, ELEVATIONS, AND DIMENSIONS IN THE FIELD PRIOR TO CONSTRUCTION. ANY DISCREPANCIES SHALL BE REPORTED TO THE ENGINEER IMMEDIATELY.
5. UNRECORDED INTERSECTIONS: CONTRACTOR SHALL VERIFY THE LOCATION OF EXISTING UNRECORDED INTERSECTIONS. CONTRACTOR SHALL CONTACT THE APPROPRIATE AGENCIES TO OBTAIN NECESSARY SAFETY DATA FOR THE PROJECT.
6. UNRECORDED UTILITIES: CONTRACTOR SHALL VERIFY THE LOCATION OF EXISTING UNRECORDED UTILITIES. CONTRACTOR SHALL CONTACT THE APPROPRIATE AGENCIES TO OBTAIN NECESSARY SAFETY DATA FOR THE PROJECT.
7. NOTICE TO PROCEED: CONTRACTOR SHALL NOT COMMENCE WORK UNTIL AFTER A NOTICE HAS BEEN ISSUED BY THE CITY.
8. TRAFFIC CONTROL: DURING CONSTRUCTION SHALL BE THE CONTRACTOR'S RESPONSIBILITY AND SHALL BE IN ACCORDANCE WITH THE CONTRACT DOCUMENTS. THE CONTRACTOR SHALL PROVIDE PASSAGE OF PUBLIC VEHICLES, BIKES, AND PEDESTRIAN TRAFFIC.
9. THE CONTRACTOR SHALL SUBMIT A DETAILED TRAFFIC CONTROL & SIGNING PLAN TO THE ENGINEER AT THE PRE-CONSTRUCTION MEETING. THE NOTICE TO PROCEED SHALL NOT BE ISSUED UNTIL SAID TRAFFIC CONTROL PLAN HAS BEEN SUBMITTED AND APPROVED BY THE CITY.
10. CONTRACTOR SHALL PROVIDE ALL NECESSARY SAFETY DEVICES IN ACCORDANCE WITH CURRENT EDITIONS OF THE CALIFORNIA MUTCD, INCLUDING BUT NOT LIMITED TO, STRIPING, SIGNS, BARRIERS, AND FLAG PERSONS.
11. CONTRACTOR SHALL KEEP EXISTING STREETS FREE FROM DIRT AND DEBRIS DURING ALL PHASES OF CONSTRUCTION.
12. CONTRACTOR SHALL PREPARE DUST CONTROL AT ALL TIMES PRIOR TO OPERATING WATER FROM FIRE HYDRANTS. CONTRACTOR SHALL OBTAIN A HYDRANT METER FROM OPERATOR OF WATER SYSTEM.
13. CONTRACTOR SHALL MAINTAIN ACCESS TO PROPERTIES ALONG BROMMER STREET THROUGHOUT THE DURATION OF CONSTRUCTION ACTIVITIES.
14. ALL EXISTING UTILITY FACILITIES WITHIN THE PROJECT SHOWN ON THE PLANS ARE TO ADJUSTED TO GRADE. BLESSED CONTRACTOR SHALL VERIFY THE LOCATION AND DEPTH OF ALL EXISTING UTILITIES. CONTRACTOR SHALL VERIFY THE LOCATION AND DEPTH OF ALL EXISTING UTILITIES. CONTRACTOR SHALL VERIFY THE LOCATION AND DEPTH OF ALL EXISTING UTILITIES. CONTRACTOR SHALL VERIFY THE LOCATION AND DEPTH OF ALL EXISTING UTILITIES. CONTRACTOR SHALL VERIFY THE LOCATION AND DEPTH OF ALL EXISTING UTILITIES.
15. UTILITY REPAIR: CONTRACTOR SHALL REPAIR ANY DAMAGE OR INTERFERENCE TO EXISTING UTILITIES CAUSED BY CONSTRUCTION IMMEDIATELY.
16. THE CONTRACTOR IS RESPONSIBLE FOR CONFIRMING EXISTING STREETS, SURROUNDING LANDSCAPE, AND OTHER IMPROVEMENTS WITH A SMOOTH TRANSITION IN PAVING AND GRADING. CONTRACTOR SHALL VERIFY THE LOCATION AND DEPTH OF ALL EXISTING UTILITIES. CONTRACTOR SHALL VERIFY THE LOCATION AND DEPTH OF ALL EXISTING UTILITIES. CONTRACTOR SHALL VERIFY THE LOCATION AND DEPTH OF ALL EXISTING UTILITIES. CONTRACTOR SHALL VERIFY THE LOCATION AND DEPTH OF ALL EXISTING UTILITIES.
17. CONTRACTOR SHALL COMPLY WITH THE RULES AND REGULATIONS OF THE STATE CONSTRUCTION SAFETY ORDERS AND CAL OSHA.
18. WHEN HANDLING ANY EARTH, SAND, GRAVEL, STONE, DEBRIS, PAPER, OR ANY OTHER SUBSTANCE OVER ANY PUBLIC STREET, ALLEY, OR PUBLIC PLACE, THE CONTRACTOR SHALL NOT ALLOW MATERIAL TO BLOW OR SPILL OVER AND UPON SAND PUBLIC, ADJACENT OR PRIVATE PROPERTY.
19. GRADING OR ANY OTHER OPERATION THAT CREATES DUST SHALL BE STOPPED IMMEDIATELY IF DUST LEVELS EXCEED THE PERMITTED LIMITS. CONTRACTOR SHALL TAKE ALL NECESSARY PRECAUTIONS TO AVOID EXCESSIVE DUST. CONTRACTOR SHALL TAKE ALL NECESSARY PRECAUTIONS TO AVOID EXCESSIVE DUST. CONTRACTOR SHALL TAKE ALL NECESSARY PRECAUTIONS TO AVOID EXCESSIVE DUST. CONTRACTOR SHALL TAKE ALL NECESSARY PRECAUTIONS TO AVOID EXCESSIVE DUST.
20. ALL NEW STORM DRAIN INLETS SHALL BE STICKED TO CROWN WITH THE CITY'S CLEAN WATER COORDINATE WITH ENGINEER.
21. ALL EXISTING IRREGULAR, LANDSCAPE MATERIALS, PAVEMENT DESTRUCTION, CURB AND GUTTER, CONSTRUCTION, SHALL BE REPLACED OR RESTORED TO EXISTING CONDITION AT NO ADDITIONAL EXPENSE TO THE CITY.
22. TREES TO REMAIN SHALL BE FLAGGED AND MARKED PRIOR TO ANY CLEARING OR GRUBBING. CONTRACTOR SHALL TAKE ALL NECESSARY PRECAUTIONS TO PROTECT REMAINING TREES. CONTRACTOR SHALL TAKE ALL NECESSARY PRECAUTIONS TO PROTECT REMAINING TREES. CONTRACTOR SHALL TAKE ALL NECESSARY PRECAUTIONS TO PROTECT REMAINING TREES. CONTRACTOR SHALL TAKE ALL NECESSARY PRECAUTIONS TO PROTECT REMAINING TREES.
23. TOPOGRAPHIC DATA SHOWN ON THESE PLANS BASED ON SURVEY DATA PROVIDED BY BOWMAN & WILLIAMS, OCTOBER 2018.
24. ROADWAY STRUCTURAL SECTIONS SHOWN ON THESE PLANS BASED ON GEOTECHNICAL INVESTIGATION PROVIDED BY BOWMAN & WILLIAMS, JANUARY 2019.

This document, together with the concepts and designs presented herein, is an instrument of service, it is intended only for the specific purpose and client for which it was prepared. Users of and improper reliance on this document without written authorization and adaptation by Kimley-Horn and Associates, Inc. shall be without liability to Kimley-Horn and Associates, Inc.

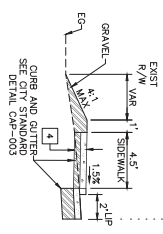
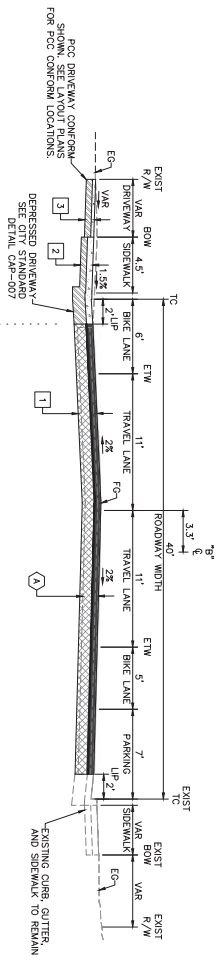

BROMMER STREET
NO SCALE
STA 18+80.32 TO STA 22+11.84
SCHEDULE A

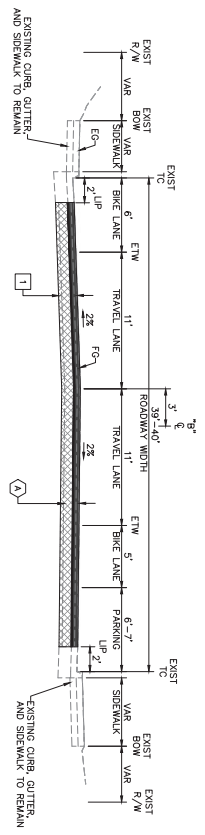

BROMMER STREET
NO SCALE
STA 15+59.91 TO STA 18+80.32
SCHEDULE A

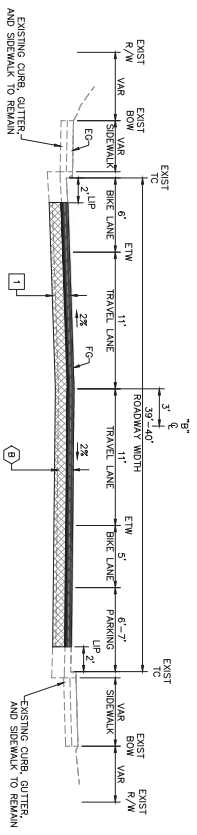

BROMMER STREET
NO SCALE
STA 12+50.00 TO STA 14+75.80
SCHEDULE B

- NOTES (THIS SHEET ONLY)**
- EXISTING PAVEMENT STRUCTURAL SECTIONS BASED ON CORE SAMPLE DATA FROM GEOTECHNICAL INVESTIGATION BY BUTANO GEOTECHNICAL ENGINEERING DATED JANUARY 2019.
 - PROPOSED PAVEMENT STRUCTURAL SECTIONS BASED ON CORE SAMPLE DATA FROM GEOTECHNICAL INVESTIGATION BY BUTANO GEOTECHNICAL ENGINEERING DATED JANUARY 2019.
 - PROPOSED PAVEMENT STRUCTURAL SECTIONS SHOWN FOR SCHEDULE A AND SCHEDULE B WALK.

- PAVEMENT STRUCTURAL SECTIONS**
- 1 0.50" HMA (TYPE A)
 - 11 & 1.00" STRESS ABSORBING MEMBRANE LAYER (SAM)
 - 1.00" FDR-C (3% CEMENT)
 - 2 0.50" FCC
 - 3 0.50" AG (CLASS 2)
 - 4 0.25" FCC
 - 5 0.50" AG (CLASS 2)
 - 6 0.33" FCC
 - 7 0.33" AG (CLASS 2)

- EXISTING PAVEMENT STRUCTURAL SECTIONS**
- 1 0.25" HMA
 - 2 1.16" AG (CLASS 2)
 - 3 0.375" HMA
 - 4 1.08" AG (CLASS 2)

- LEGEND**
- 1 PORTLAND CEMENT CONCRETE [FCC] (SIDEWALK/CURB/GUTTER/DRIVEWAY)
 - 2 AGGREGATE BASE [AB] (CLASS 2)
 - 3 HOT MIX ASPHALT [HMA] (TYPE A)
 - 4 FULL DEPTH RECLAMATION [FDR]

NO.	REVISIONS	DATE	BY

Kimley-Horn
© 2019 KIMLEY-HORN AND ASSOCIATES, INC.
100 WEST 28th STREET, SUITE 500, SAN DIEGO, CA 92101
PHONE: 619-444-1430
WWW.KIMLEY-HORN.COM

BROMMER COMPLETE STREET IMPROVEMENTS
PREPARED FOR
CITY OF CAPITOLA
SANTA CRUZ COUNTY
CITY OF CAPITOLA



TYPICAL SECTIONS

SHEET NO. - 2
OF - 13 - SHEETS
X-1



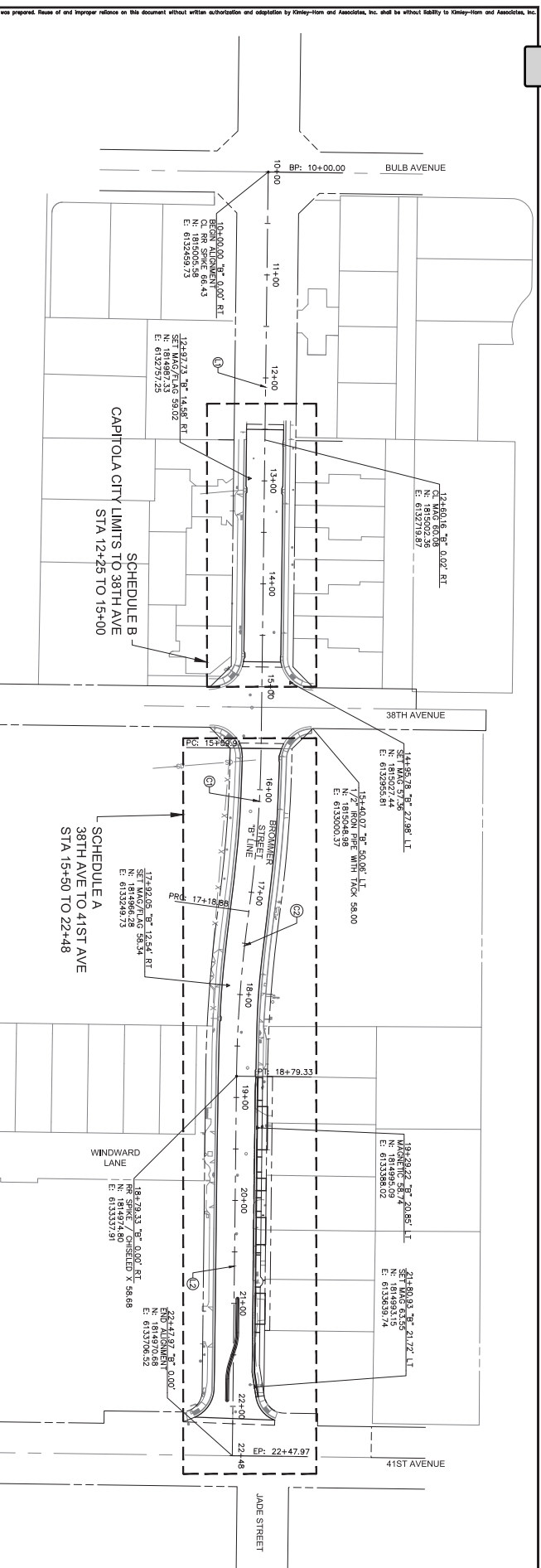

ALIGNMENT LINE TABLE

LINE	LENGTH	BEARING
L1	559.91	S89°43'51.51"E
L2	368.64	S89°43'56.14"E

ALIGNMENT CURVE TABLE

CURVE	RADIUS	LENGTH	CHORD BEARING	CHORD	DELTA	TANGENT
C1	1265.52'	158.97'	S89°41'40"E	158.97'	71°15'	79.59'
C2	1265.90'	160.45'	S85°43'36"E	160.34'	71°54'	80.33'

GENERAL PROJECT NOTES

1. THE BASIS OF BEARINGS FOR THIS SURVEY IS THE CALCULATED BEARING BETWEEN THE FOUND RAILROAD SPIKE AT THE INTERSECTION OF BULB AVENUE AND BROMMER STREET AND THE FOUND RAILROAD SPIKE WITH CHISELED X AT THE NORTHEAST CORNER OF LOT 0, AS SHOWN ON RECORD MAP 1641000, SAN DIEGO COUNTY RECORDS MAP 885957, W.
2. THE BASIS OF ELEVATIONS FOR THIS MAP IS THE COUNTY OF SANTA CRUZ BENCHMARK NO. 4 (NAVD83). DESCRIPTION: PAINTED BOLT AT THE SOUTHWESTERLY BASE OF CROSSING SIGNAL AT THE NORTHWEST CORNER OF INTERSECTION OF RAILROAD AND 41ST AVENUE HELD AT ELEVATION 66.66 (NAVD83).
3. THIS SURVEY DOES NOT REPRESENT A COMPLETE BOUNDARY SURVEY. ALL PROPERTY CORNERS SURVEYED AND NEW CORNERS OR MONUMENTS HAVE NOT BEEN SET DURING THIS SURVEY. THE BOUNDARY (PROPERTY) LINES SHOWN HEREON ARE APPROXIMATE AND ARE BASED ON RECORD MAP 1641000, SAN DIEGO COUNTY RECORDS MAP 885957, W. AND FIELD MEASUREMENTS AND FIELD SURVEYING AND THE PHYSICAL LOCATION OF EXISTING MONUMENTS.
4. CONTRACTOR IS RESPONSIBLE FOR SURVEY MONUMENT PRESERVATION, PREPARE A PRE AND POST CONSTRUCTION CORNER RECORD FOR MONUMENTS IN PROJECT CONSTRUCTION AREA.
5. THE PROJECT IS SEPARATED INTO TWO SCHEDULES. SCHEDULE A INCLUDES ALL CONSTRUCTION IMPROVEMENTS ON BROMMER STREET BETWEEN 38TH AVENUE AND 41ST AVENUE. SCHEDULE B INCLUDES ALL CONSTRUCTION IMPROVEMENTS ON BROMMER STREET BETWEEN CITY OF CAPITOLA WESTERN CITY LIMITS AND 38TH AVENUE.

REGIONS

No.	DATE	BY

Kimley-Horn

© 2019 KIMLEY-HORN AND ASSOCIATES, INC.
100 WEST 34th STREET, SUITE 400, SAN ANTONIO, TX 78215
PHONE: 682-400-4139
WWW.KIMLEY-HORN.COM

KHA PROJECT: 09/17/2019
SCALE: AS SHOWN
DESIGNED BY: DW
DRAWN BY: DJW
CHECKED BY: DC

BROMMER COMPLETE STREET IMPROVEMENTS
PREPARED FOR CITY OF CAPITOLA
SANTA CRUZ COUNTY, CA



HORIZONTAL CONTROL

SHEET NO. 3
OF 13 SHEETS
HC-1

This document, together with the concepts and designs presented herein, is intended only for the specific purpose and client for which it was prepared. Use of or improper reliance on this document without written authorization and adaptation by Kimley-Horn and Associates, Inc. shall be without liability to Kimley-Horn and Associates, Inc.

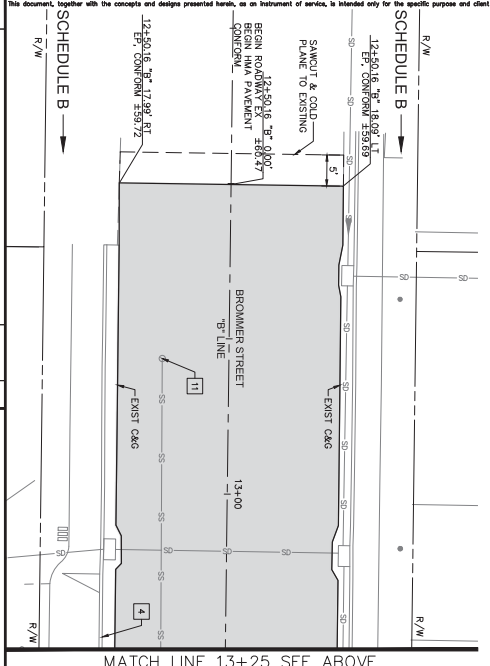
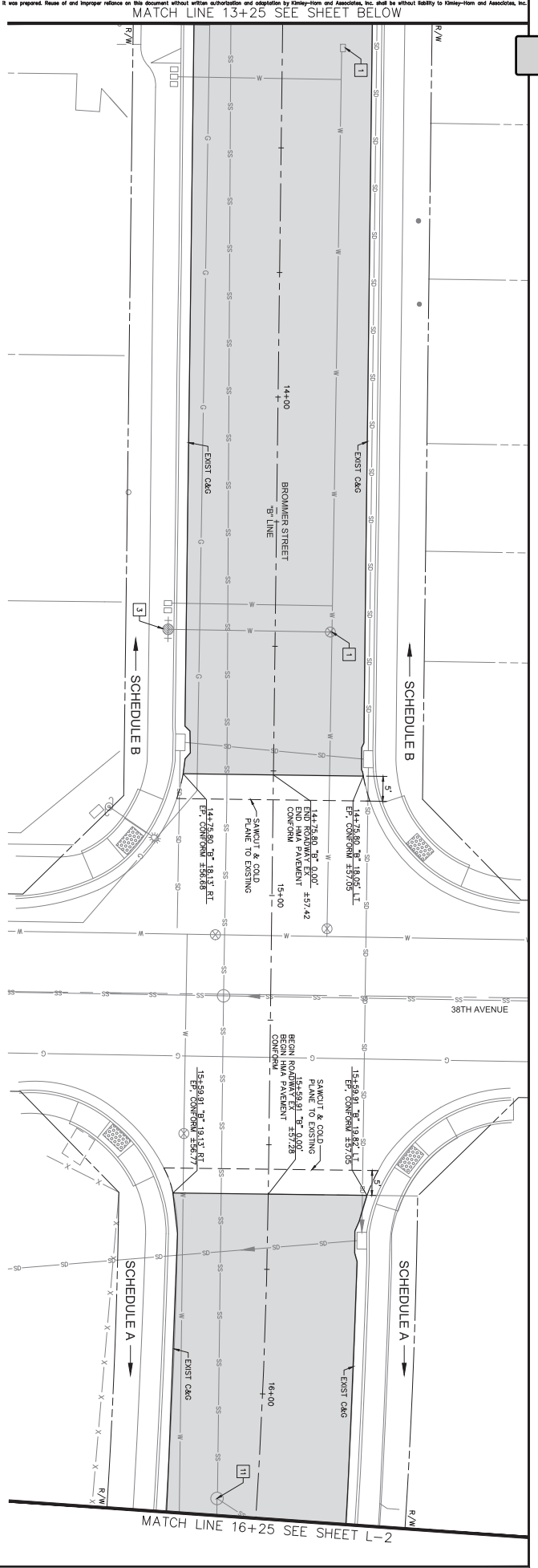

GENERAL CONSTRUCTION NOTES

1. SAWCUT SHALL BE PER CITY DETAIL C&G-002 ON A NEXT LINE WITHOUT DAMAGING EXISTING AC CURB, GUTTER, OR SIDEWALK. MATERIAL TO REMAIN SHALL BE REPAIRED OR REPLACED TO A CONDITION SATISFACTORY TO THE ENGINEER AT THE CONTRACTOR'S EXPENSE.
2. CURB, GUTTER, AND SIDEWALK IMPROVEMENTS SHOWN ARE BASED ON EXISTING OR VERTICAL PROFILE ELEVATIONS AT PROPOSED UP OF GUTTER.
3. ALL STATION CALLOUTS REFERENCE "B" LINE STATIONS, UNLESS OTHERWISE NOTED.
4. CONTRACTOR SHALL VERIFY ALL RIGHTS OF WAY PRIOR TO CONSTRUCTION.
5. SEE TYPICAL SECTIONS FOR STANDARD SIDEWALK, CURB AND GUTTER, AND DRIVEWAY SECTIONS.
6. SEE CONSTRUCTION DETAIL SHEETS FOR CURB, DRIVEWAY, SIDEWALK, MEDIAN, AND DRAINAGE DETAILS.
7. SEE SIGNING AND STRIPING PLAN FOR PAVEMENT DELINEATION AND SIGNING DETAILS.
8. ALL TREES NOT SPECIFICALLY INDICATED FOR REMOVAL SHALL BE PROTECTED IN PLACE. ANY ADDITIONAL EXPENSE TO THE CITY.
9. IF TREE ROOTS ARE ENCOUNTERED DURING EXCAVATION THEY SHALL BE PROTECTED AND A PROTECTIVE SHIELD SHALL BE ENHANCED TO PROVIDE PROTECTION TO PROTECTED TREE AND ROOTS FROM DAMAGE.
10. SEE TILE AND H-C-01 SHEET FOR TRANSLATION OF NORTHING AND EASTING PROJECT COORDINATES TO NORTH AMERICAN DATUM (NAD83).
11. EXISTING UTILITIES ARE PRESENT CLOSE TO THE PROPOSED WORK. CONTRACTOR SHALL POHPOE AND FIELD LOCATE EXISTING UTILITIES AND NOTIFY THE ENGINEER OF ANY CONFLICTS WITH THE PROPOSED WORK PRIOR TO THE START OF CONSTRUCTION.
12. UTILITIES SHOWN ARE BASED ON SCHEMATIC AS-BUILT DATA, SURFACE OBSERVATIONS OF RESPONSIBILITY FOR LOCATIONS, DEPTHS, OR FUNCTIONS OF ALL UTILITIES SHOWN HEREON. SOME UNDERGROUND UTILITIES MAY NOT BE SHOWN.
13. REMOVE EXISTING DETECTOR LOOPS AT BROMMER/1ST AVE WEST INTERSECTION LEG. SAWCUT AND INSTALL PROPOSED DETECTOR LOOPS AS SHOWN PER CALTRANS STANDARD PLAN ES-5A AND ES-5B.
14. SPLICE EXISTING D/C WITH NEW DETECTOR LOOP WIRE AT TRAFFIC SIGNAL PULL BOX.

LEGEND

- HMA (SEE TYPICAL SECTIONS)
- PCC (CURB/GUTTER/SIDEWALK/DRIVEWAY)
- PCC (DRIVEWAY CONFORM)
- SAWCUT
- GAS LINE
- OVERHEAD UTILITY LINE(S)
- SS— SANITARY SEWER LINE
- S— STORM DRAIN LINE
- W— WATER LINE
- (X) DETAIL NO. / SHEET REFERENCE
- C&G CURB AND GUTTER

CONSTRUCTION NOTES

- 1 ADJUST EXISTING WATER MANHOLES TO GRADE
- 2 EXISTING UTILITY POLE TO REMAIN
- 3 EXISTING FIRE HYDRANT TO REMAIN
- 4 EXISTING DRIVEWAY TO REMAIN
- 5 EXISTING FENCE TO REMAIN
- 6 DRIVEWAY CONFORM (PCC)
- 7 ADJUST EXISTING WATER VALVE BOXES TO GRADE
- 8 RELOCATE EXISTING MAILBOX
- 9 CALTRANS TYPE A LOOP DETECTOR
- 10 CALTRANS TYPE D LOOP DETECTOR
- 11 ADJUST EXISTING SANITARY SEWER MANHOLES TO GRADE

	<p>Kimley-Horn</p> <p>© 2019 KIMLEY-HORN AND ASSOCIATES, INC. 100 WEST 24th STREET, SUITE 400, DENVER, CO 80202 PHONE: 303-733-1139 WWW.KIMLEY-HORN.COM</p>	<p>BROMMER COMPLETE STREET IMPROVEMENTS</p> <p>PREPARED FOR CITY OF CAPITOLA</p>	<p>LAYOUT PLAN</p> <p>SHEET NO. - 4 OF - 13 SHEETS L-1</p>
<p>NO. _____</p> <p>REVISIONS _____</p>	<p>DATE _____ BY _____</p>	<p>DATE SPOKE: Nov. 20, 2019</p>	<p>GRAPHIC SCALE IN FEET 0 5 10 20</p>

This document, together with the concepts and designs presented herein, is an instrument of service, is intended only for the specific purpose and client for which it was prepared. Users of and improper reliance on this document without written authorization and approval by Kimley-Horn and Associates, Inc. shall be without liability to Kimley-Horn and Associates, Inc.

APN 036-09-430
302 PARK AVE
LOT 20

APN 034-16-443
3865 BROMMER ST

APN 034-16-416
3881 BROMMER ST

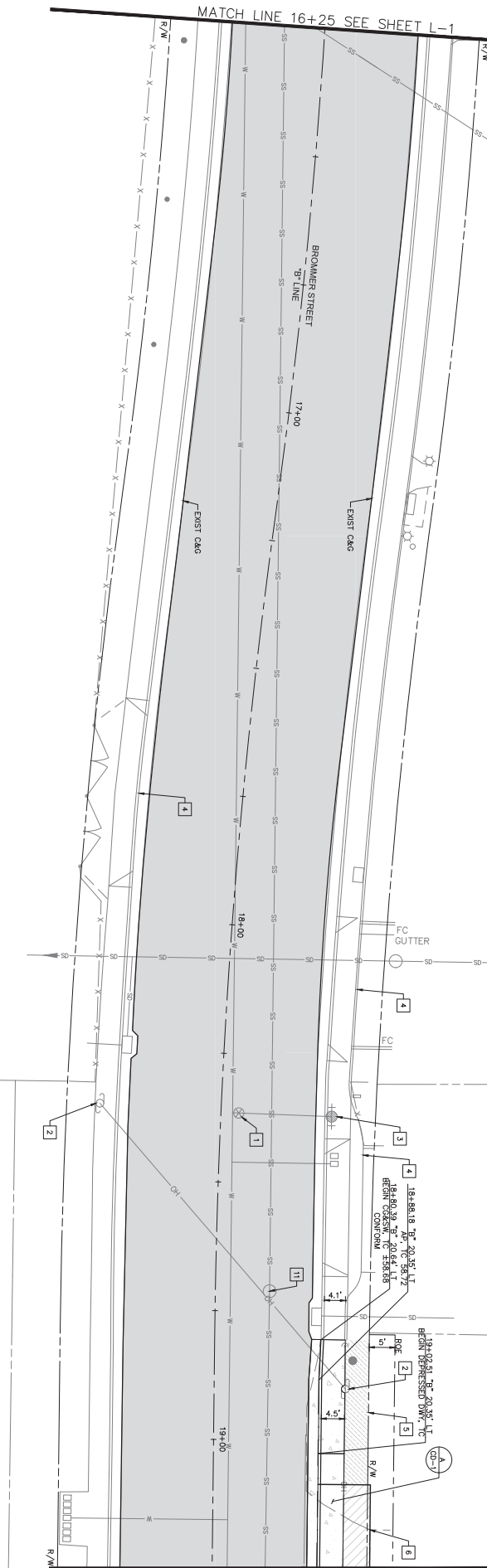

LEGEND

- 1 MAH (SEE TYPICAL SECTIONS)
- 2 PCC CURB/GUTTER/SIDEWALK/DRIVEWAY
- 3 PCC (DRIVEWAY CONFORM)
- 4 GRAVEL
- 5 SAMCUT
- 6 GAS LINE
- 7 OVERHEAD UTILITY LINE(S)
- 8 SANITARY SEWER LINE
- 9 STORM DRAIN LINE
- 10 WATER LINE
- 11 DETAIL NO. / SHEET REFERENCE
- 12 C&G CURB AND GUTTER

CONSTRUCTION NOTES

- 1 ADJUST EXISTING WATER MANHOLES TO GRADE
- 2 EXISTING UTILITY POLE TO REMAIN
- 3 EXISTING FIRE HYDRANT TO REMAIN
- 4 EXISTING FENCE TO REMAIN
- 5 EXISTING DRIVEWAY TO REMAIN
- 6 DRIVEWAY CONFORM (PCC)
- 7 ADJUST EXISTING WATER VALVE BOXES TO GRADE
- 8 RELOCATE EXISTING MAILBOX
- 9 CALTRANS TYPE A LOOP DETECTOR
- 10 CALTRANS TYPE B LOOP DETECTOR
- 11 ADJUST EXISTING SANITARY SEWER MANHOLES TO GRADE

GENERAL CONSTRUCTION NOTES

1. SAMCUT SHALL BE PER CITY DETAIL CAP-002 ON A NEXT LINE WITHOUT DAMAGING EXISTING AC MATERIAL TO REMAIN. ALL EXISTING UTILITIES SHALL BE REPAIRED OR REPLACED TO A CONDITION SATISFACTORY TO THE CONTRACTOR'S EXPENSE.
2. CURB, GUTTER, AND SIDEWALK IMPROVEMENTS SHOWN ARE BASED ON EXISTING OR VERTICAL PROFILE ELEVATIONS AT PROPOSED UP OF GUTTER.
3. ALL STATION CALLOUTS REFERENCE "B" LINE STATIONS, UNLESS OTHERWISE NOTED.
4. CONTRACTOR SHALL VERIFY ALL RIGHTS OF WAY PRIOR TO CONSTRUCTION.
5. SEE TYPICAL SECTIONS FOR STANDARD SIDEWALK, CURB AND GUTTER, AND DRIVEWAY SECTIONS.
6. SEE CONSTRUCTION DETAIL SHEETS FOR CURB, DRIVEWAY, SIDEWALK, MEDIAN, AND DRAINAGE DETAILS.
7. SEE SIGNING AND STRIPING PLAN FOR PAVEMENT DELINEATION AND SIGNING DETAILS.
8. ALL TREES NOT SPECIFICALLY INDICATED FOR REMOVAL SHALL BE PROTECTED IN KIND AT NO ADDITIONAL EXPENSE TO THE CITY.
9. IF TREE ROOTS ARE ENCOUNTERED DURING EXCAVATION THEY SHALL BE PROTECTED AND A TREE PROTECTION SYSTEM SHALL BE INSTALLED TO PROTECT TREE AND ROOTS FROM DAMAGE.
10. SEE TITLE AND H-C-01 SHEET FOR TRANSLATION OF NORTHING AND EASTING PROJECT COORDINATES TO NORTH AMERICAN DATUM (NAD83).
11. EXISTING UTILITIES ARE PRESENT CLOSE TO THE PROPOSED WORK. CONTRACTOR SHALL POHOFE AND FIELD LOCATE EXISTING UTILITIES AND NOTIFY THE ENGINEER OF ANY CONTACTS WITH THE PROPOSED WORK PRIOR TO THE START OF CONSTRUCTION.
12. UTILITIES SHOWN ARE BASED ON SCHEMATIC AS-BUILT DATA, SURFACE OBSERVATIONS OF EXISTING UTILITIES, AND FIELD DATA. THE LOCATION, DEPTH, AND FUNCTION OF ALL UTILITIES SHOWN HEREON, SOME UNDERGROUND UTILITIES MAY NOT BE SHOWN.
13. REMOVE EXISTING DETECTOR LOOPS AT BROMMER/1ST AVE WEST INTERSECTION LEG. SAMCUT AND INSTALL PROPOSED DETECTOR LOOPS AS SHOWN PER CALTRANS STANDARD PLAN ES-5A AND ES-5B.
14. SPLICE EXISTING DLC WITH NEW DETECTOR LOOP WIRE AT TRAFFIC SIGNAL PULL BOX.

NO.	REVISIONS	DATE	BY

Kimley-Horn
© 2019 KIMLEY-HORN AND ASSOCIATES, INC.
100 WEST 24th STREET, SUITE 200, DENVER, CO 80202, USA 97113
WWW.KIMLEY-HORN.COM
PHONE: 866-400-4139

NO.	REVISIONS	DATE	BY

BROMMER COMPLETE STREET IMPROVEMENTS
PREPARED FOR
CITY OF CAPITOLA
SANTA CRUZ COUNTY



LAYOUT PLAN

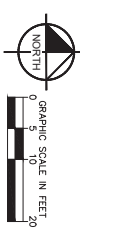

SHEET NO. - 5
OF - 13 SHEETS
L-2



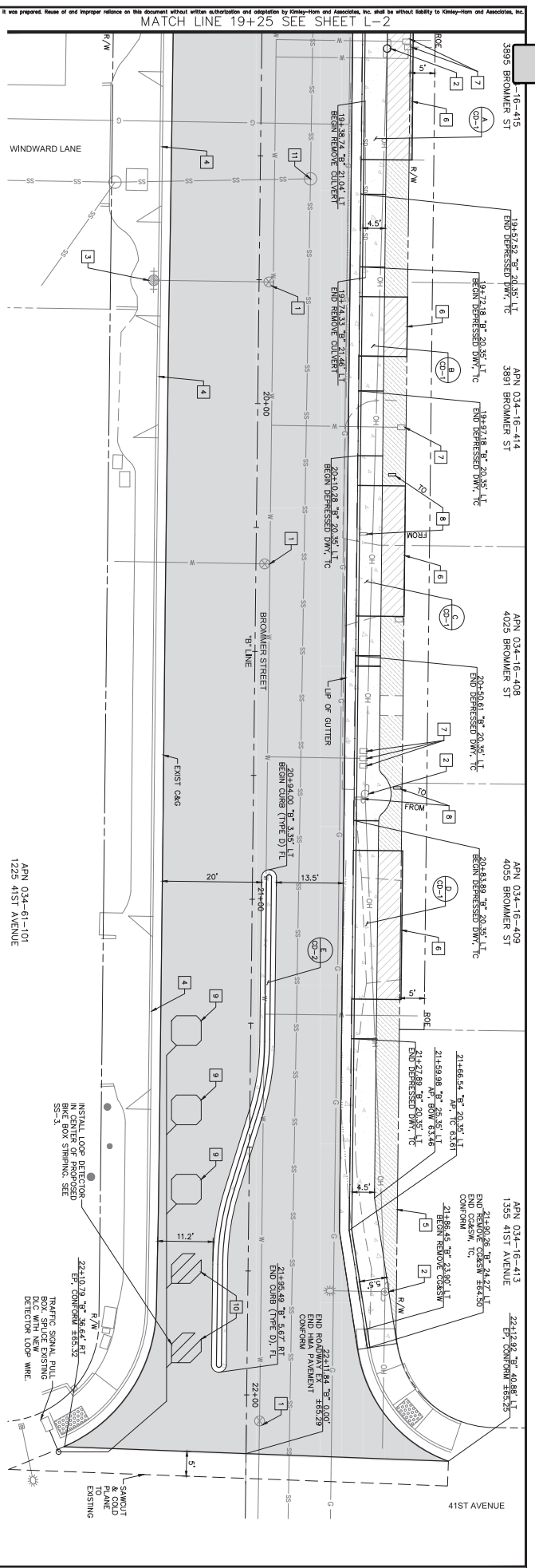

LEGEND

- 1 HMA (SEE TYPICAL SECTIONS)
- 2 FCC (CURB/GUTTER/SIDEWALK/DRIVEWAY)
- 3 FCC (PNEWAYWAY CONFORM)
- 4 GRAVEL
- 5 SAMCUT
- 6 G - GAS LINE
- 7 OH - OVERHEAD UTILITY LINE(S)
- 8 SS - SANITARY SEWER LINE
- 9 SP - STORM DRAIN LINE
- 10 W - WATER LINE
- 11 (XX) DETAIL NO. / SHEET REFERENCE

CONSTRUCTION NOTES

- 1 ADJUST EXISTING WATER MANHOLES TO GRADE
- 2 EXISTING UTILITY FOLE TO REMAIN
- 3 EXISTING FIRE PROGRAM TO REMAIN
- 4 EXISTING DRIVEWAY TO REMAIN
- 5 DRIVEWAY CONFORM (FCC)
- 6 ADJUST EXISTING WATER VALVE BOXES TO GRADE
- 7 RELOCATE EXISTING MAILBOX
- 8 CALTRANS TYPE A LOOP DETECTOR
- 9 CALTRANS TYPE D LOOP DETECTOR
- 10 ADJUST EXISTING SANITARY SEWER MANHOLES TO GRADE

GENERAL CONSTRUCTION NOTES

1. SAMCUT SHALL BE PER CITY DETAIL CAP-002 ON A NEARLY UNIFORM DAMAGING EXISTING AC MATERIAL TO BE REPAIRED OR REPLACED TO A CONDITION SATISFACTORY TO THE ENGINEER AT THE CONTRACTOR'S EXPENSE.
2. CURB, GUTTER, AND SIDEWALK IMPROVEMENTS SHOWN ARE BASED ON EXISTING OR VERTICAL PROFILE ELEVATIONS AT PROPOSED UP OF GUTTER.
3. ALL STATION CALLOUTS REFERENCE "P" LINE STATIONS, UNLESS OTHERWISE NOTED.
4. CONTRACTOR SHALL VERIFY ALL RIGHTS OF WAY PRIOR TO CONSTRUCTION.
5. SEE TYPICAL SECTIONS FOR STANDARD SIDEWALK, CURB AND GUTTER, AND DRIVEWAY SECTIONS.
6. SEE CONSTRUCTION DETAIL SHEETS FOR CURB, DRIVEWAY, SIDEWALK, MEDIAN, AND DRAINAGE DETAILS.
7. SEE SIGNING AND STRIPING PLAN FOR PAVEMENT DELINEATION AND SIGNING DETAILS.
8. ALL TREES NOT SPECIFICALLY INDICATED FOR REMOVAL SHALL BE PROTECTED IN KIND AT NO ADDITIONAL EXPENSE TO THE CITY.
9. IF TREE ROOTS ARE ENCOUNTERED DURING EXCAVATION THEY SHALL BE PROTECTED AND A TREE PROTECTION PLAN SHALL BE SUBMITTED TO THE CITY.
10. SEE TILE AND H-C-OI SHEET FOR TRANSLATION OF NORTHING AND EASTING PROJECT COORDINATES TO NORTH AMERICAN DATUM (NAD83).
11. EXISTING UTILITIES ARE PRESENT CLOSE TO THE PROPOSED WORK. CONTRACTOR SHALL POINTE AND FIELD LOCATE EXISTING UTILITIES AND NOTIFY THE ENGINEER OF ANY CONFLICTS WITH THE PROPOSED WORK PRIOR TO THE START OF CONSTRUCTION.
12. UTILITIES SHOWN ARE BASED ON SCHEMATIC AS-BUILT DATA, SURFACE OBSERVATIONS OF RESPONSIBILITY FOR LOCATIONS APPLICABLE TO FUNCTIONALITY OF ALL UTILITIES SHOWN HEREON. SOME UNDERGROUND UTILITIES MAY NOT BE SHOWN.
13. REMOVE EXISTING DETECTOR LOOPS AT BROMMER/41ST AVE WEST INTERSECTION LEG. SAMCUT AND INSTALL PROPOSED DETECTOR LOOPS AS SHOWN PER CALTRANS STANDARD PLAN ES-5A AND ES-5B.
14. SPRUCE EXISTING D/C WITH NEW DETECTOR LOOP WIRE AT TRAFFIC SIGNAL PULL BOX.

NO.	REVISIONS	DATE	BY

Kimley»Horn

© 2018 KIMLEY-HORN AND ASSOCIATES, INC.
100 WEST 34th STREET, SUITE 400, DENVER, CO 80202, USA 97113
WWW.KIMLEY-HORN.COM

BROMMER COMPLETE STREET IMPROVEMENTS

PREPARED FOR
CITY OF CAPITOLA

CA



LAYOUT PLAN

DATE: 10-20-2018

SHEET NO. - 6
OF - 13 SHEETS

L-3

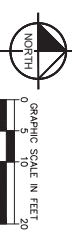

This document, together with the concepts and designs presented herein, is an instrument of service, is intended only for the specific purpose and client for which it was prepared. Please do not make or rely on this document without written authorization and adaptation by Kimley-Horn and Associates, Inc. shall be without liability to Kimley-Horn and Associates, Inc.

- GENERAL PROFILE NOTES**
- EXISTING CENTERLINE PROFILE SHOWN IS APPROXIMATE BASED ON TOPOGRAPHIC DATA PROVIDED BY BISHMAN & WILDMAN, OCTOBER 2019

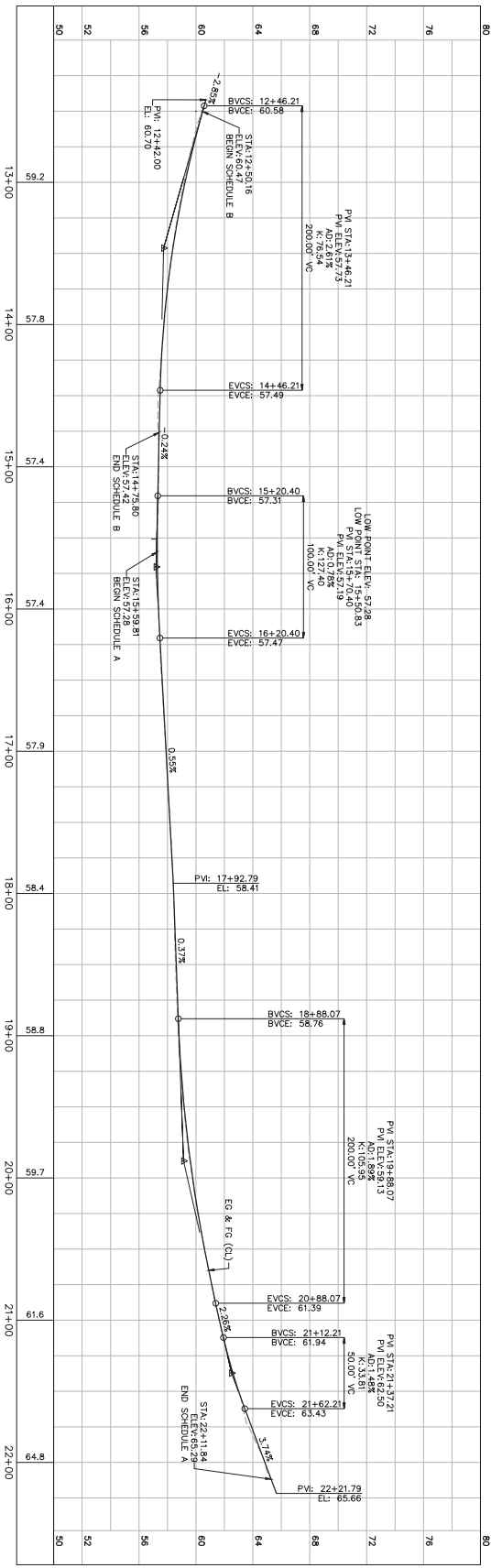

"B LINE"
BROMMER STREET

SCALE:
HORIZONTAL 1" = 40'
VERTICAL 1" = 4'

NO.	REVISIONS	DATE	BY

Kimley-Horn

© 2019 KIMLEY-HORN AND ASSOCIATES, INC.
100 WEST 2ND STREET, SUITE 2000, SAN DIEGO, CA 92101
PHONE: 619-441-4139
WWW.KIMLEY-HORN.COM

KHA PROJECT	09/27/2019
DESIGNED BY	DJW
DRAWN BY	DJW
CHECKED BY	DC

BROMMER COMPLETE STREET IMPROVEMENTS
PREPARED FOR
CITY OF CAPITOLA
SANTA CRUZ COUNTY
CA



ROADWAY PROFILE



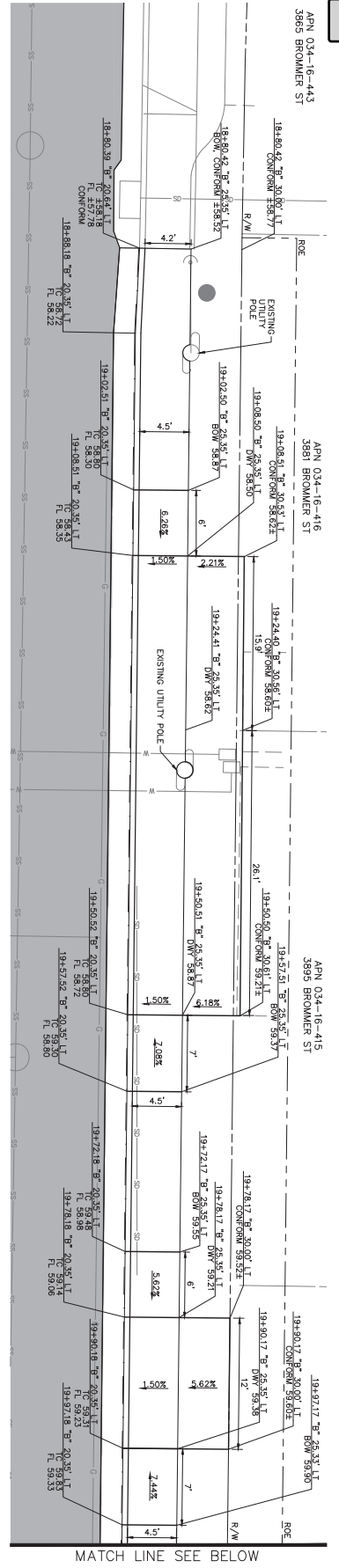

DRIVEWAY DETAIL A

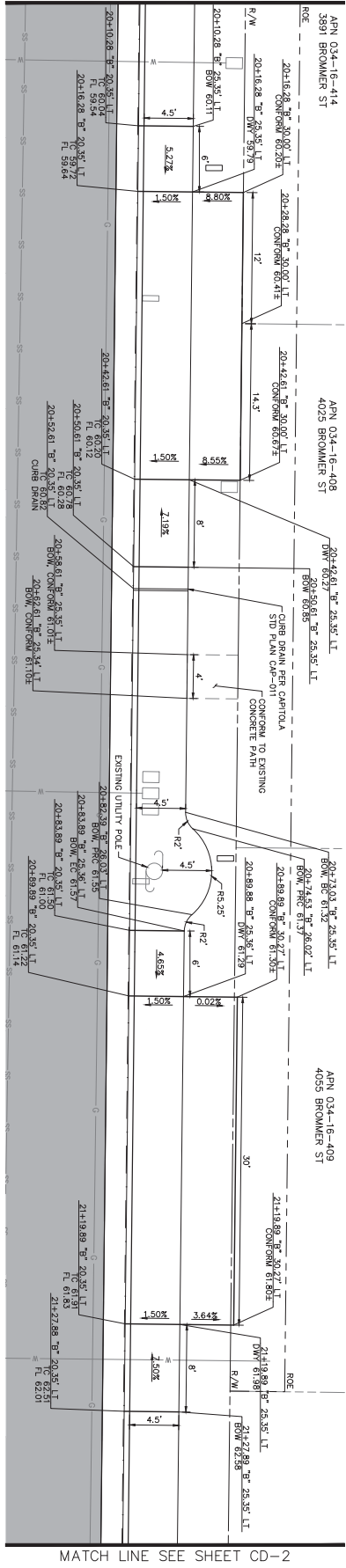

DRIVEWAY DETAIL B

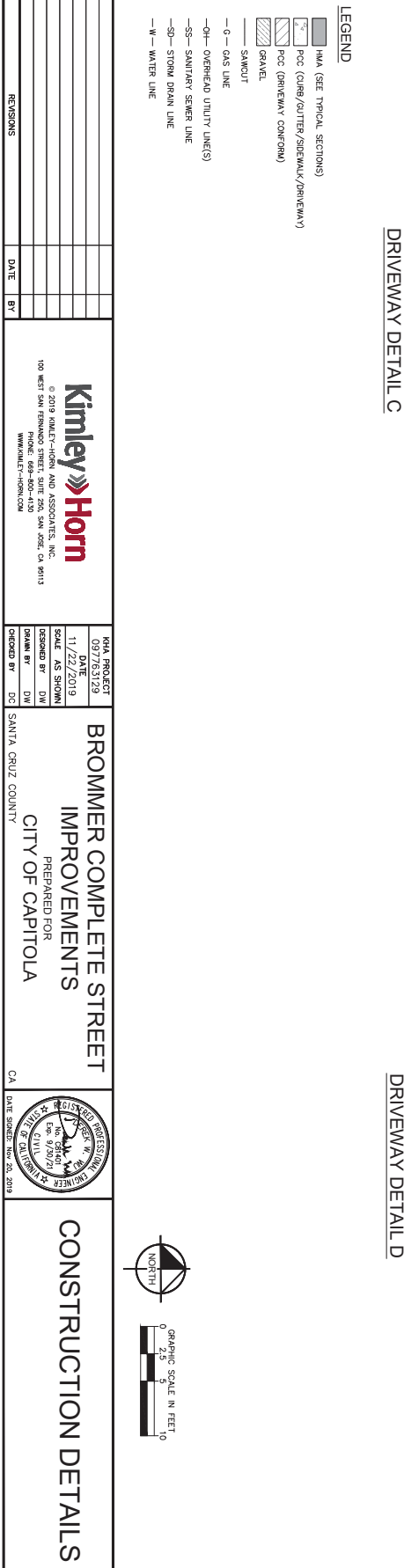

DRIVEWAY DETAIL C

- LEGEND**
- HMA (SEE TYPICAL SECTIONS)
 - ▨ PCC (CURB/GUTTER/SIDEWALK/DRIVEWAY)
 - ▨ PCC (DRIVEWAY CONFORM)
 - ▨ GRAVEL
 - ▨ SAWCUT
 - G — GAS LINE
 - OH — OVERHEAD UTILITY LINES
 - SS — SANITARY SEWER LINE
 - SD — STORM DRAIN LINE
 - W — WATER LINE

Kimley-Horn

© 2019 KIMLEY-HORN AND ASSOCIATES, INC.
100 WEST 24th STREET, SUITE 500, DENVER, CO 80202, USA 303.733.1913
WWW.KIMLEY-HORN.COM

BROMMER COMPLETE STREET IMPROVEMENTS

PREPARED FOR
CITY OF CAPITOLA

CA SANTA CRUZ COUNTY

PROFESSIONAL ENGINEER
KIMLEY-HORN AND ASSOCIATES, INC.
No. 112212019
Exp. 9/30/24

CONSTRUCTION DETAILS

SHEET NO. - 8
OF - 13 SHEETS
CD-1

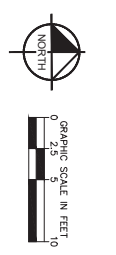

This document, together with the concepts and designs presented herein, is an instrument of service, is intended only for the specific purpose and client for which it was prepared. Release of and improper reliance on this document without written authorization and adoption by Kimley-Horn and Associates, Inc. shall be without liability to Kimley-Horn and Associates, Inc.

APN 034-16-413
1359 41ST AVENUE

MATCH LINE SEE SHEET CD-1

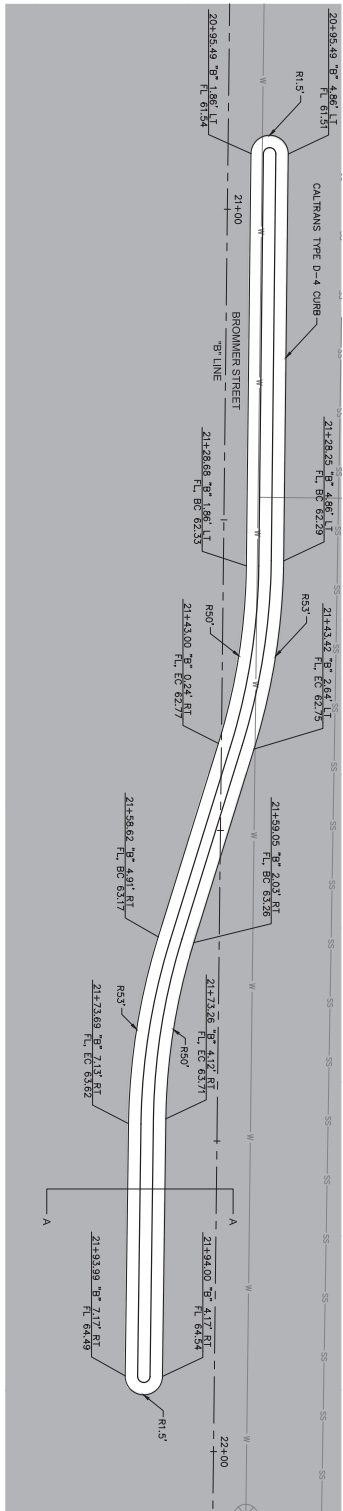
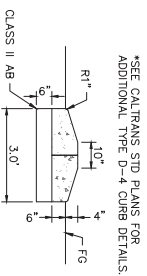
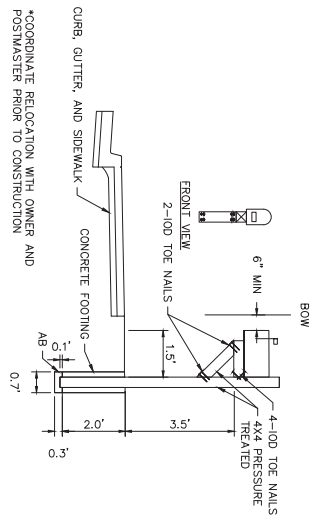
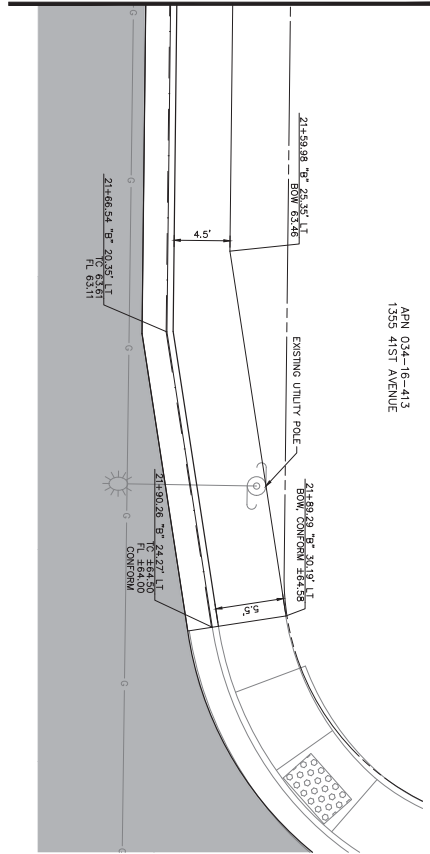

MEDIAN DETAIL E



NO.	REVISIONS	DATE	BY

Kimley-Horn
© 2019 KIMLEY-HORN AND ASSOCIATES, INC.
100 WEST 24TH STREET, SUITE 200, DENVER, CO 80202, USA 303.733.1113
WWW.KIMLEY-HORN.COM

QA PROJECT	09/17/2019
DESIGNED BY	DW
DRAWN BY	DW
CHECKED BY	DC

BROWNER COMPLETE STREET IMPROVEMENTS
PREPARED FOR
CITY OF CAPITOLA
SANTA CRUZ COUNTY, CA



CONSTRUCTION DETAILS

SHEET NO. 8
OF 13 SHEETS
CD-2

This document, together with the concepts and designs presented herein, is an instrument of service, is intended only for the specific purpose and client for which it was prepared. Please do not make or rely on this document without written authorization and adaptation by Kimley-Horn and Associates, Inc. shall be without liability to Kimley-Horn and Associates, Inc.

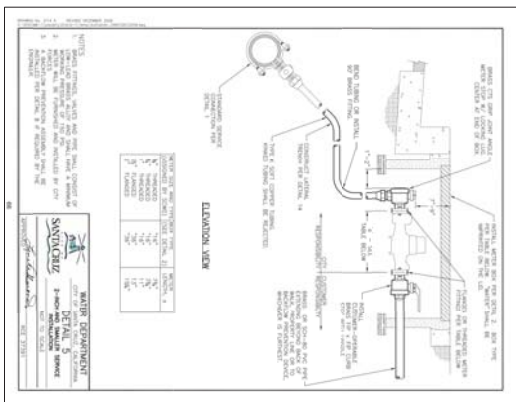
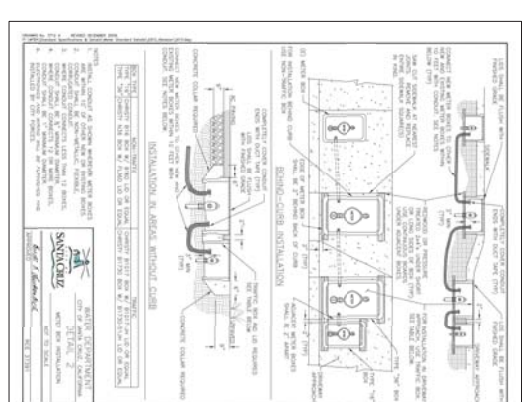
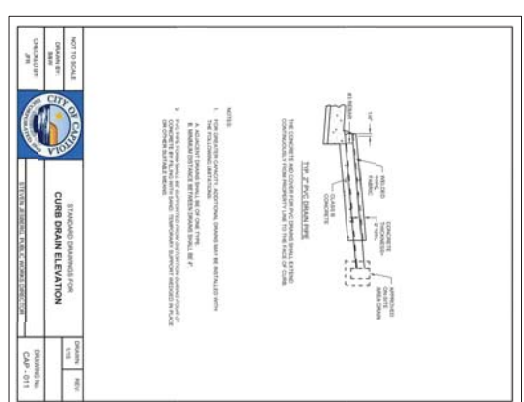
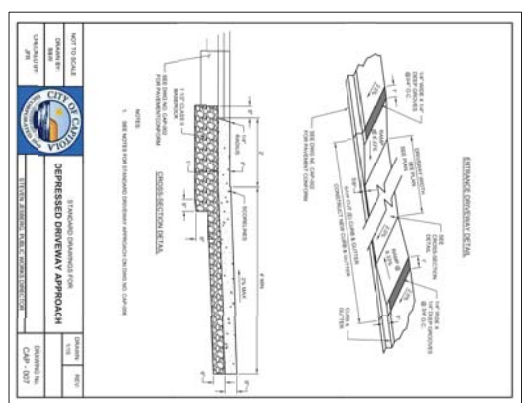
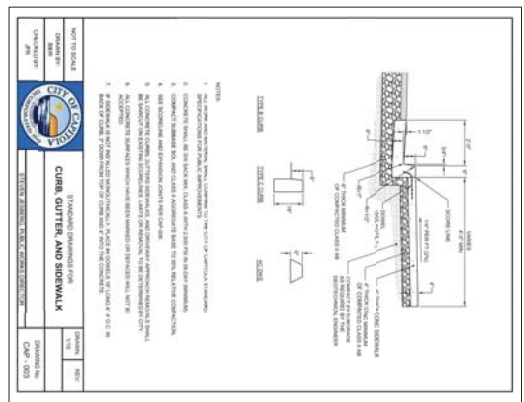

Kimley-Horn

© 2019 KIMLEY-HORN AND ASSOCIATES, INC.
100 WEST SAN TERCERO AVENUE, SUITE 202, SANTA CRUZ, CA 95113
WWW.KIMLEY-HORN.COM

BROMMER COMPLETE STREET IMPROVEMENTS
PREPARED FOR
CITY OF CAPITOLA

CA 1-800-277-8000

DATE: 11/22/2019

DESIGNED BY: DW

DRAWN BY: DW

CHECKED BY: DC

SANTA CRUZ COUNTY

CA 1-800-277-8000

100 WEST SAN TERCERO AVENUE, SUITE 202, SANTA CRUZ, CA 95113

WWW.KIMLEY-HORN.COM

© 2019 KIMLEY-HORN AND ASSOCIATES, INC.



SHEET NO. - 10
OF - 13 - SHEETS
CD-3

CONSTRUCTION DETAILS

5.B.1

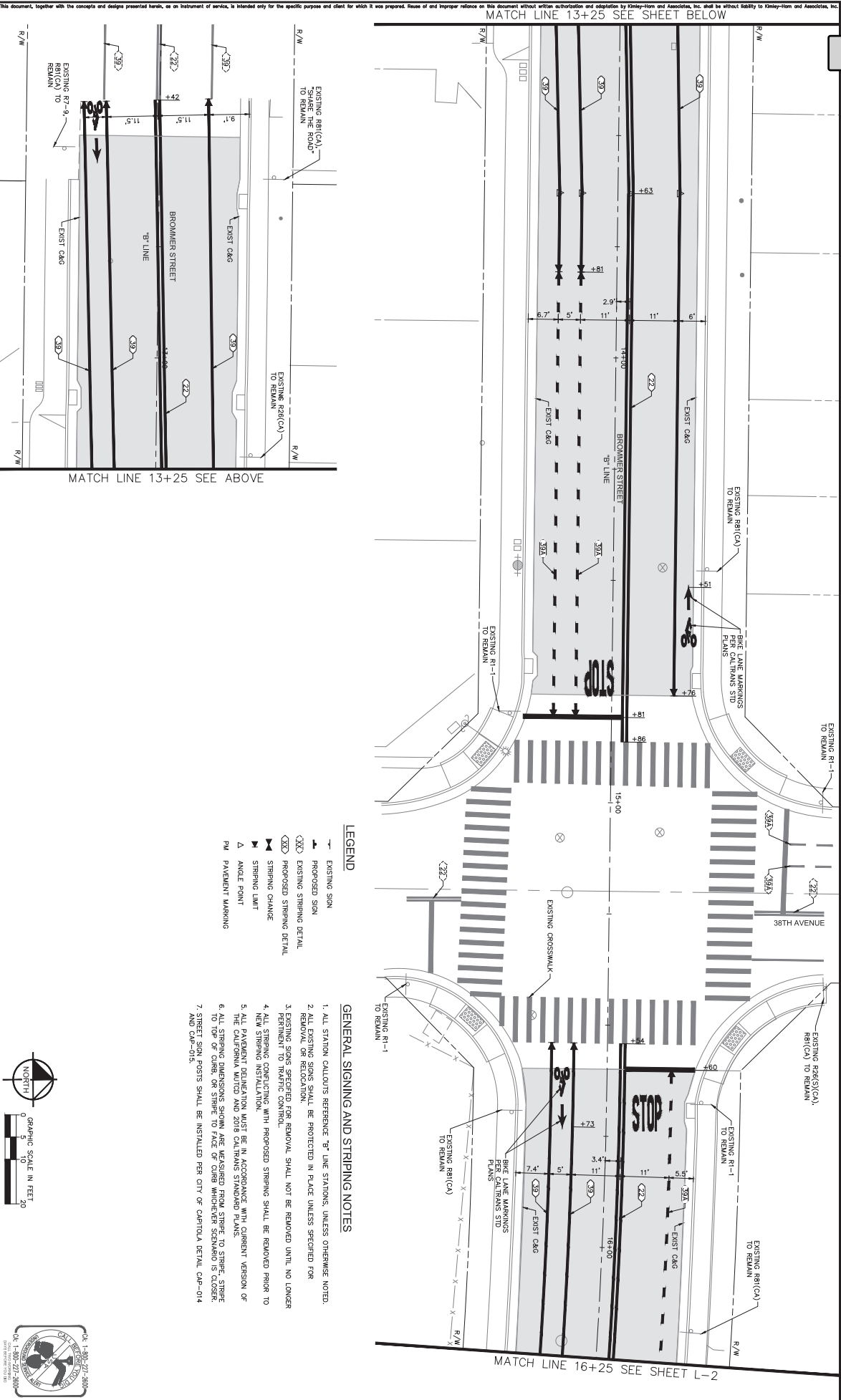

LEGEND

- EXISTING SIGN
- ▲ PROPOSED SIGN
- ⊗ EXISTING STRIPING DETAIL
- ⊗ PROPOSED STRIPING DETAIL
- ⚡ STRIPING CHANGE
- ▬ STRIPING LIMIT
- △ ANGLE POINT
- PM PAVEMENT MARKING

GENERAL SIGNING AND STRIPING NOTES

1. ALL STATION CALLOUTS REFERENCE "B" LINE STATIONS, UNLESS OTHERWISE NOTED.
2. ALL EXISTING SIGNS SHALL BE PROTECTED IN PLACE UNLESS SPECIFIED FOR REMOVAL OR RELOCATION.
3. EXISTING SIGNS SPECIFIED FOR REMOVAL SHALL NOT BE REMOVED UNTIL NO LONGER PERTINENT TO TRAFFIC CONTROL.
4. ALL STRIPING INSTALLATION WITH PROPOSED STRIPING SHALL BE REMOVED PRIOR TO NEW STRIPING INSTALLATION.
5. ALL PAVEMENT DELINEATION MUST BE IN ACCORDANCE WITH CURRENT VERSION OF THE CALIFORNIA WIDTH AND 2018 CALTRANS STANDARD PLANS.
6. ALL STRIPING DIMENSIONS SHOWN ARE MEASURED FROM STRIPE TO STRIPE, STRIPE TO TOP OF CURB, OR STRIPE TO FACE OF CURB UNLESS OTHERWISE SPECIFIED IS CLOSER.
7. STREET SIGN POSTS SHALL BE INSTALLED PER CITY OF CAPITOLA DETAIL CAP-014 AND CAP-015.

		KIMLEY-HORN 100 WEST 20th STREET SUITE 200 DENVER, CO 80202 PHONE: 303-733-1313 WWW.KIMLEY-HORN.COM
KIMLEY-HORN PROJECT 09/27/2019 11/22/2019 SCALE AS SHOWN DESIGNED BY: DJM DRAWN BY: DJM CHECKED BY: DJM DATE: 11/22/2019	BROMMER COMPLETE STREET IMPROVEMENTS PREPARED FOR CITY OF CAPITOLA SANTA CRUZ COUNTY CA DATE SUBMITTED: NOV. 22, 2019	
SIGNING AND STRIPING PLAN		SHEET NO. 11 OF 13 SHEETS SS-1

This document, together with the concepts and designs presented herein, is an instrument of service, is intended only for the specific purpose and client for which it was prepared. Please do not make or rely on this document without written authorization and approval by Kimley-Horn and Associates, Inc. and be without liability to Kimley-Horn and Associates, Inc.

APN 036-09-430
302 PARK AVE
LOT 20

APN 034-16-443
3865 BROMMER ST

APN 034-16-416
3881 BROMMER ST

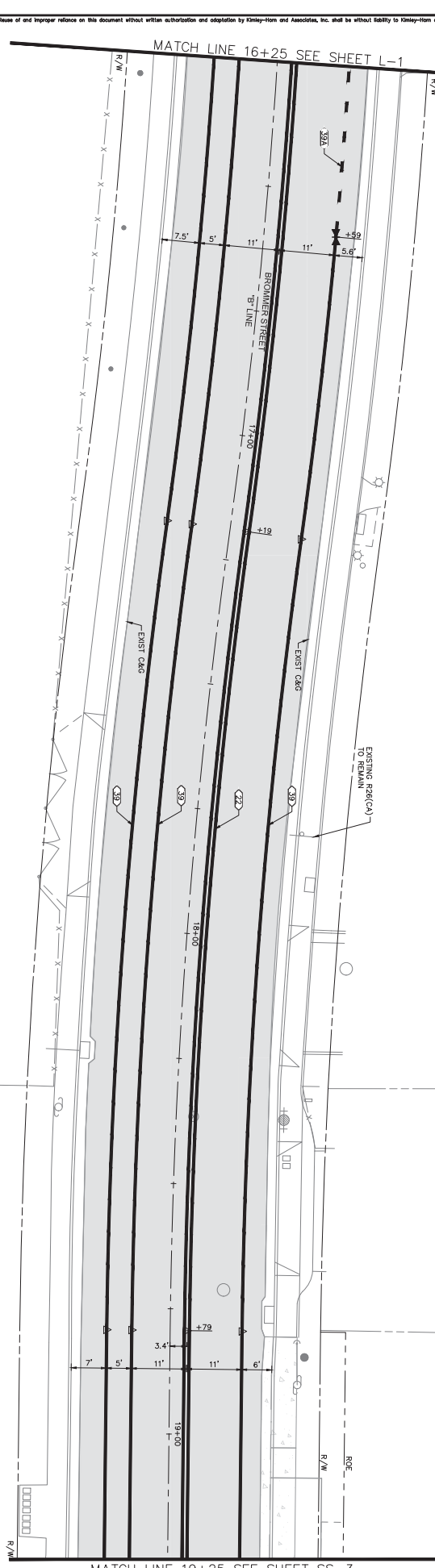

LEGEND

- EXISTING SIGN
 - ▲ PROPOSED SIGN
 - <X> EXISTING STRIPING DETAIL
 - <X> PROPOSED STRIPING DETAIL
 - STRIPING CHANGE
 - STRIPING LIMIT
 - ▲ ANGLE POINT
 - PM PAVEMENT MARKINGS
- GENERAL SIGNING AND STRIPING NOTES**
- ALL STATION CALLOUTS REFERENCE "P" LINE STATIONS, UNLESS OTHERWISE NOTED.
 - ALL EXISTING SIGNS SHALL BE PROTECTED IN PLACE UNLESS SPECIFIED FOR REMOVAL OR RELOCATION.
 - EXISTING SIGNS SPECIFIED FOR REMOVAL SHALL NOT BE REMOVED UNTIL NO LONGER PERTINENT TO TRAFFIC CONTROL.
 - ALL STRIPING CONFLICTING WITH PROPOSED STRIPING SHALL BE REMOVED PRIOR TO NEW STRIPING INSTALLATION.
 - ALL PAVEMENT DELINEATION MUST BE IN ACCORDANCE WITH CURRENT VERSION OF THE CALIFORNIA MUTCD AND 2018 CALTRANS STANDARD PLANS.
 - ALL STRIPING DIMENSIONS SHOWN ARE MEASURED FROM STRIPE TO STRIPE, STRIPE TO TOP OF CURB, OR STRIPE TO FACE OF CURB WHICHEVER SOLUTION IS CLEARER.
 - STREET SIGN POSTS SHALL BE INSTALLED PER CITY OF CARPUELA DETAIL CAP-014 AND CAP-015.

STRIPING AND MARKING SCHEDULE

DETAIL	PATTERN OR LEGEND	LF	SOFT
22	CENTURINE	1567	—
25	LEFT EDGELINE & 6" DIAGONAL	188	—
39	BIKE LANE LINE (BIKE LANE)	1999	—
39A	INTERSECTION LINE (BIKE LANE)	333	—
PM	*"STOP" MARKINGS	—	44
PM	*"KEEP CLEAR" MARKINGS	—	36
PM	TYPE VII ARROW	—	51
PM	CONTINENTAL CROSSWALK MARKING	—	194
PM	STOP BAR MARKING	—	66
PM	BIKE SYMBOL/ARROW MARKING	—	30
PM	SHARROW MARKING	—	24
PM	GREEN PAINT FOR BIKE LANE & BOX	—	201
	TOTAL	4097	666.0

SIGN SCHEDULE

DETAIL	STATION	DESCRIPTION	EA
R2-2	21+14	NO LEFT TURN	1
R2-7aP	21+55	EXCEPT BICYCLES	1
R4-7	20+94	KEEP RIGHT	1
R4-11	20+94	BIKES MAY USE FULL LANE	1
R10-6A	21+55	STOP HERE ON RED	1
R10-11A	22+48	NO TURN ON RED	1
R28(CA)	21+36	NO PARKING	1
FR1(CA)	20+94, 21+62	BIKE LANE	2
FR1(CA)	21+62	BEIGN	1
FR1(CA)	20+94	END	1
OM2-2H	20+94, 21+98	TYPE 2 OBJECT MARKER	2
	TOTAL		13



Kimley-Horn

© 2019 KIMLEY-HORN AND ASSOCIATES, INC.
100 WEST 20th STREET, SUITE 500, SAN DIEGO, CA 92113
WWW.KIMLEY-HORN.COM

KHA PROJECT
09/17/2019

SCALE AS SHOWN
11/22/2019

DESIGNED BY: DMW

DRAWN BY: DMW

CHECKED BY: DC

SANTA CRUZ COUNTY

CA 1-800-277-8600

GRAPHIC SCALE IN FEET
0 5 10 20

BROMMER COMPLETE STREET IMPROVEMENTS

PREPARED FOR
CITY OF CAPITOLA

SIGNING AND STRIPING PLAN

SHEET NO. 12
OF 13 SHEETS

SS-2

This document, together with the concepts and designs presented herein, is an instrument of service, is intended only for the specific purpose and client for which it was prepared. Users of and improper reliance on this document without written authorization and adaptation by Kimley-Horn and Associates, Inc. shall be without liability to Kimley-Horn and Associates, Inc.

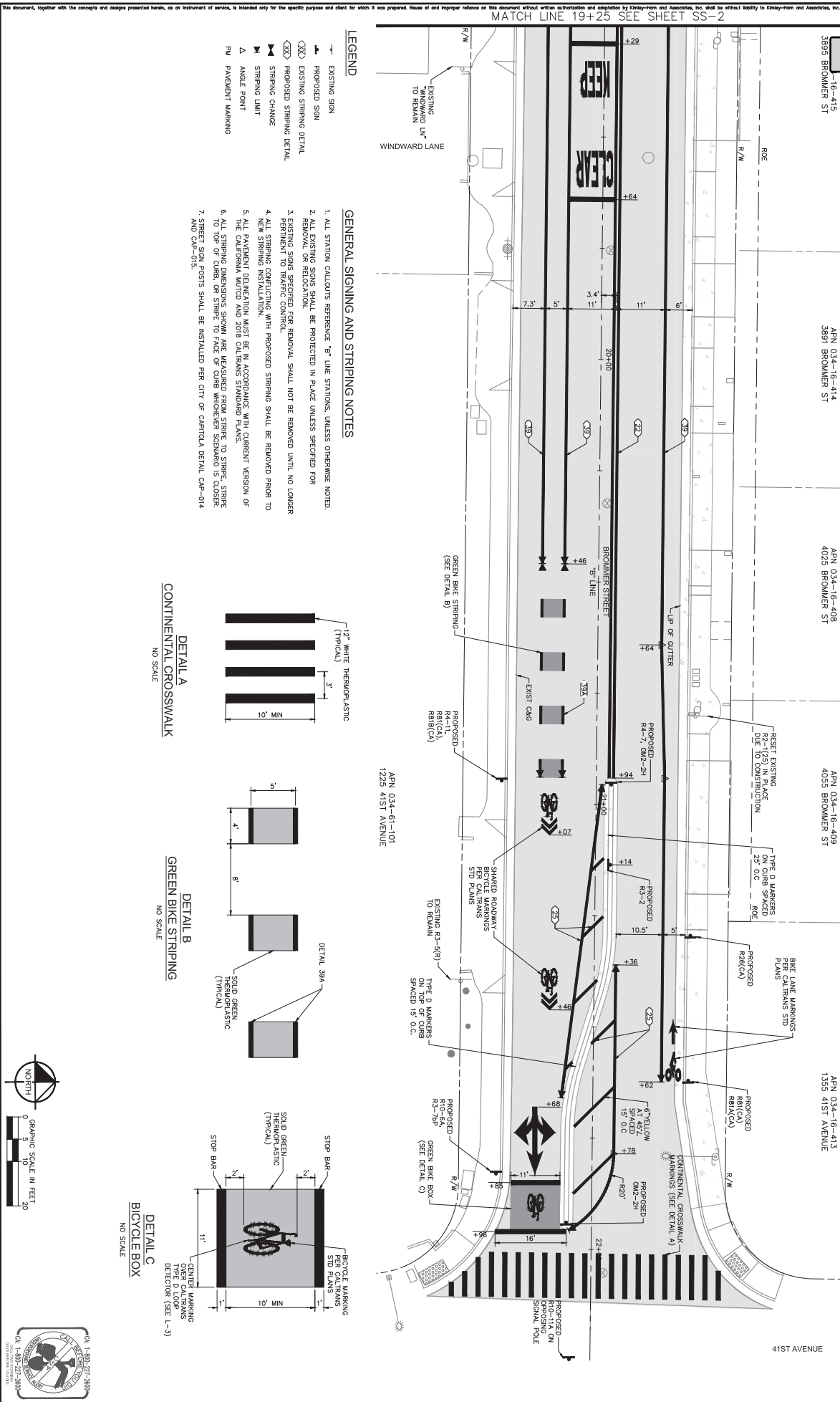

LEGEND

- EXISTING SIGN
- ▲ PROPOSED SIGN
- <X> EXISTING STRIPING DETAIL
- <X> PROPOSED STRIPING DETAIL
- <X> PROPOSED STRIPING CHANGE
- <X> STRIPING LIMIT
- ▲ ANGLE POINT
- PM PAVEMENT MARKINGS

GENERAL SIGNING AND STRIPING NOTES

1. ALL STATION CALLOUTS REFERENCE "P" LINE STATIONS, UNLESS OTHERWISE NOTED.
2. ALL EXISTING SIGNS SHALL BE PROTECTED IN PLACE UNLESS SPECIFIED FOR REMOVAL OR RELOCATION.
3. EXISTING SIGNS SPECIFIED FOR REMOVAL SHALL NOT BE REMOVED UNTIL NO LONGER PERTINENT TO TRAFFIC CONTROL.
4. ALL STRIPING CONFLICTING WITH PROPOSED STRIPING SHALL BE REMOVED PRIOR TO NEW STRIPING INSTALLATION.
5. ALL PAVEMENT DELINEATION MUST BE IN ACCORDANCE WITH CURRENT VERSION OF THE CALIFORNIA MUTCD AND 2018 CALTRANS STANDARD PLANS.
6. ALL STRIPING DIMENSIONS SHOWN ARE MEASURED FROM STRIPE TO STRIPE, STRIPE TO TOP OF CURB, OR STRIPE TO FACE OF CURB UNLESS OTHERWISE SPECIFIED IS CLEAR.
7. STREET SIGN POSTS SHALL BE INSTALLED PER CITY OF CARPUELA DETAIL CAP-014 AND CAP-015.

**DETAIL A
CONTINENTAL CROSSWALK
NO SCALE**

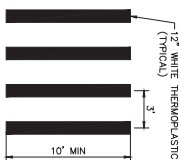

**DETAIL B
GREEN BIKE STRIPING
NO SCALE**

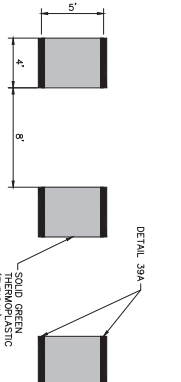

**DETAIL C
BICYCLE BOX
NO SCALE**

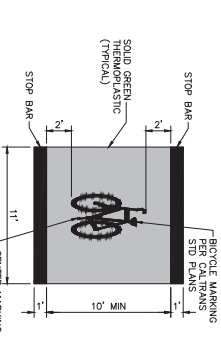

<p>Kimley-Horn</p> <p>© 2019 KIMLEY-HORN AND ASSOCIATES, INC. 100 WEST 29th STREET, SUITE 400, DENVER, CO 80202, USA 303.733.1911 WWW.KIMLEY-HORN.COM</p>		<p>KHA PROJECT 09/27/2019 11/22/2019 SCALE AS SHOWN DESIGNED BY: DM DRAWN BY: DM CHECKED BY: DC</p>		<p>BROMMER COMPLETE STREET IMPROVEMENTS PREPARED FOR CITY OF CARPUELA SANTA CRUZ COUNTY</p>		<p>CA DATE SHOWN: Nov. 20, 2019</p>		<p>SIGNING AND STRIPING PLAN</p>		<p>SHEET NO. - 13 OF - 13 - SHEETS SS-3</p>	
No.	REVISIONS	DATE	BY								

This document, together with the concepts and designs presented herein, is an instrument of service, is intended only for the specific purpose and client for which it was prepared. Please do not and do not rely on this document without written authorization and approval by Kimley-Horn and Associates, Inc. and without liability to Kimley-Horn and Associates, Inc.



STAFF REPORT

TO: PLANNING COMMISSION

FROM: COMMUNITY DEVELOPMENT

DATE: JANUARY 16, 2020

SUBJECT: **Update to Zoning Ordinance/Local Coastal Plan Implementation Plan**

Update to the City of Capitola Zoning Code including Chapter 17.74 Accessory Dwelling Units, density limits in Chapter 17.25 Commercial and Industrial Zoning Districts, and temporary sign standards and non-commercial messaging in Chapter 17.80 Signs.

The Zoning Code serves as the Implementation Plan of the City's Local Coastal Program and therefore must be certified by the Coastal Commission.

Environmental Determination: Addendum to the General Plan Update EIR

Property: The Zoning Code update affects all properties within the City of Capitola.

Representative: Matt Orbach, Associate Planner, City of Capitola

BACKGROUND:

Following adoption of the general plan in 2014, staff began the process of updating the City's zoning code, which was adopted by the City Council on January 25, 2018. Since the adoption of the zoning code, staff has been working with Coastal Commission toward certification of the new code within the coastal zone which currently is under review by the City Council. The changes to the zoning code proposed in this staff report will be submitted for Coastal Commission certification separate from the comprehensive zoning code update with the goal of having them certified expeditiously to bring the code into compliance with state legislation and for consistency with the General Plan.

DISCUSSION:

There are three proposed zoning code amendments within the current review. The first part of this zoning code update proposes to remove the maximum residential density limits in the C-R and C-C zoning district sections to ensure consistency with the General Plan amendment of 2019. The second part proposes updates to Chapter 17.74 regulating Accessory Dwelling Units (ADUs) in order to be in compliance with new state laws. The third amendment is to the Chapter 17.80 regulating signs to incorporate non-commercial allowances based on recent court rulings.

During the January 16, 2020, Planning Commission meeting, staff will provide an overview of recent legislation requiring modifications to ADUs. The state legislation includes substantial changes which require major modifications to Capitola's current ADU regulations. Staff will also introduce the future amendments to commercial density limits and non-commercial signs. On February 6, 2020, the three zoning code amendments will be published in full.

Density limits in CC and CR zones: Staff identified that the residential density limits in the Community Commercial (CC) and Regional Commercial (CR) zoning districts are not in conformance with the General Plan as amended in 2019. Staff is proposing that the maximum residential density limits in the CC and CR zoning districts be removed from Table 17.24-3 on page 24-5. The action would bring the zoning code into conformance with the General Plan, with the development standards of floor area ratio, height, setbacks, open space, and parking establishing the limits for residential and commercial development in commercial and mixed-use zones.

Chapter 17.74: Accessory Dwelling Units: Major changes in state law effective in 2020 require that Capitola update the regulations for ADUs. The state mandated modifications include:

1. Requires action on ADU applications within 60 days. Additional changes to existing permit requirements include clarification on what is considered action on an application and permit requirements for an ADU subject to a discretionary permit.
2. Requires the city to ministerially approve four certain types of ADUs subjected to limited standards. For these types of ADUs, the City may not require compliance with any additional development or design standards.
3. Expands permitted location to include any zoning district where single-family or multi-family dwellings are allowed. This includes all residential, mixed-use, and commercial zoning districts.
4. Allows more than one ADU per parcel in certain circumstances on multi-family properties.
5. Allow a Junior ADU in conjunction with a detached ADU on a single-family property in certain circumstances.
6. Prohibits the City from applying development standards that would prevent a 16-foot-tall, 800-square-foot ADU four feet from rear and side property lines.
7. Allows conversion and replacement of existing structures with nonconforming setbacks and building separation standards for ADUs.
8. Development standards:
 - a. Removed minimum parcel size
 - b. Increased maximum unit size
 - c. Reduced minimum setbacks
 - d. Increased height for one-story detached ADU
9. Removes parking requirements for internal ADUs, attached ADUs, and junior ADUs. Removes parking for detached ADUs with certain characteristics, such as being located within one-half mile walking distance of public transit.
10. Limits review to objective standards (measurable, quantitative) and architectural standards (specific siding design or window type) rather than subjective development standards (compatibility, privacy).
11. Allows objective standards to minimize adverse impacts to historic properties consistent with the Secretary of the Interior Standards for the Treatment of Historic Properties.
12. Removes size, attribute, and owner-occupancy deed restriction requirements for all ADUs except junior ADUs.
13. Provides an option for cities to allow separate sale of deed-restricted affordable ADUs by a non-profit corporation.

Chapter 17.80: Signs: The City Attorney has recommended several changes to the regulations for signs based on court rulings. Those changes include:

1. Adding language allowing noncommercial content wherever commercial content is allowed.
2. Adding definitions for “commercial message,” “commercial sign,” and “election period.”

3. Adding a section allowing small temporary noncommercial signs on residential property.

CEQA: An Addendum to the General Plan Update Environmental Impact Report (EIR) was adopted for the amendment to the Zoning Code of Chapter 17.

STAFF RECOMMENDATION:

Accept staff presentation and continue this item to the February 6, 2020, Planning Commission meeting.

ATTACHMENTS:

1. Government Code 65852.2 - Accessory Dwelling Units - 01.01.2020
2. Government Code 65852.22 - Junior Accessory Dwelling Units - 01.01.2020
3. Health and Safety Code 18007 - Manufactured Homes - 01.01.2008

Prepared By: Matt Orbach
Associate Planner

State of California

GOVERNMENT CODE

Section 65852.2

65852.2. (a) (1) A local agency may, by ordinance, provide for the creation of accessory dwelling units in areas zoned to allow single-family or multifamily dwelling residential use. The ordinance shall do all of the following:

(A) Designate areas within the jurisdiction of the local agency where accessory dwelling units may be permitted. The designation of areas may be based on the adequacy of water and sewer services and the impact of accessory dwelling units on traffic flow and public safety. A local agency that does not provide water or sewer services shall consult with the local water or sewer service provider regarding the adequacy of water and sewer services before designating an area where accessory dwelling units may be permitted.

(B) (i) Impose standards on accessory dwelling units that include, but are not limited to, parking, height, setback, landscape, architectural review, maximum size of a unit, and standards that prevent adverse impacts on any real property that is listed in the California Register of Historic Resources. These standards shall not include requirements on minimum lot size.

(ii) Notwithstanding clause (i), a local agency may reduce or eliminate parking requirements for any accessory dwelling unit located within its jurisdiction.

(C) Provide that accessory dwelling units do not exceed the allowable density for the lot upon which the accessory dwelling unit is located, and that accessory dwelling units are a residential use that is consistent with the existing general plan and zoning designation for the lot.

(D) Require the accessory dwelling units to comply with all of the following:

(i) The accessory dwelling unit may be rented separate from the primary residence, but may not be sold or otherwise conveyed separate from the primary residence.

(ii) The lot is zoned to allow single-family or multifamily dwelling residential use and includes a proposed or existing dwelling.

(iii) The accessory dwelling unit is either attached to, or located within, the proposed or existing primary dwelling, including attached garages, storage areas or similar uses, or an accessory structure or detached from the proposed or existing primary dwelling and located on the same lot as the proposed or existing primary dwelling.

(iv) If there is an existing primary dwelling, the total floor area of an attached accessory dwelling unit shall not exceed 50 percent of the existing primary dwelling.

(v) The total floor area for a detached accessory dwelling unit shall not exceed 1,200 square feet.

(vi) No passageway shall be required in conjunction with the construction of an accessory dwelling unit.

(vii) No setback shall be required for an existing living area or accessory structure or a structure constructed in the same location and to the same dimensions as an existing structure that is converted to an accessory dwelling unit or to a portion of an accessory dwelling unit, and a setback of no more than four feet from the side and rear lot lines shall be required for an accessory dwelling unit that is not converted from an existing structure or a new structure constructed in the same location and to the same dimensions as an existing structure.

(viii) Local building code requirements that apply to detached dwellings, as appropriate.

(ix) Approval by the local health officer where a private sewage disposal system is being used, if required.

(x) (I) Parking requirements for accessory dwelling units shall not exceed one parking space per accessory dwelling unit or per bedroom, whichever is less. These spaces may be provided as tandem parking on a driveway.

(II) Offstreet parking shall be permitted in setback areas in locations determined by the local agency or through tandem parking, unless specific findings are made that parking in setback areas or tandem parking is not feasible based upon specific site or regional topographical or fire and life safety conditions.

(III) This clause shall not apply to an accessory dwelling unit that is described in subdivision (d).

(xi) When a garage, carport, or covered parking structure is demolished in conjunction with the construction of an accessory dwelling unit or converted to an accessory dwelling unit, the local agency shall not require that those offstreet parking spaces be replaced.

(xii) Accessory dwelling units shall not be required to provide fire sprinklers if they are not required for the primary residence.

(2) The ordinance shall not be considered in the application of any local ordinance, policy, or program to limit residential growth.

(3) A permit application for an accessory dwelling unit or a junior accessory dwelling unit shall be considered and approved ministerially without discretionary review or a hearing, notwithstanding Section 65901 or 65906 or any local ordinance regulating the issuance of variances or special use permits. The permitting agency shall act on the application to create an accessory dwelling unit or a junior accessory dwelling unit within 60 days from the date the local agency receives a completed application if there is an existing single-family or multifamily dwelling on the lot. If the permit application to create an accessory dwelling unit or a junior accessory dwelling unit is submitted with a permit application to create a new single-family dwelling on the lot, the permitting agency may delay acting on the permit application for the accessory dwelling unit or the junior accessory dwelling unit until the permitting agency acts on the permit application to create the new single-family dwelling, but the application to create the accessory dwelling unit or junior accessory dwelling unit shall be considered without discretionary review or hearing. If the applicant requests a delay, the 60-day time period shall be tolled for the period of the delay. A local agency may charge a fee to reimburse it for costs incurred to implement this paragraph,

including the costs of adopting or amending any ordinance that provides for the creation of an accessory dwelling unit.

(4) An existing ordinance governing the creation of an accessory dwelling unit by a local agency or an accessory dwelling ordinance adopted by a local agency shall provide an approval process that includes only ministerial provisions for the approval of accessory dwelling units and shall not include any discretionary processes, provisions, or requirements for those units, except as otherwise provided in this subdivision. If a local agency has an existing accessory dwelling unit ordinance that fails to meet the requirements of this subdivision, that ordinance shall be null and void and that agency shall thereafter apply the standards established in this subdivision for the approval of accessory dwelling units, unless and until the agency adopts an ordinance that complies with this section.

(5) No other local ordinance, policy, or regulation shall be the basis for the delay or denial of a building permit or a use permit under this subdivision.

(6) This subdivision establishes the maximum standards that local agencies shall use to evaluate a proposed accessory dwelling unit on a lot that includes a proposed or existing single-family dwelling. No additional standards, other than those provided in this subdivision, shall be used or imposed, including any owner-occupant requirement, except that a local agency may require that the property be used for rentals of terms longer than 30 days.

(7) A local agency may amend its zoning ordinance or general plan to incorporate the policies, procedures, or other provisions applicable to the creation of an accessory dwelling unit if these provisions are consistent with the limitations of this subdivision.

(8) An accessory dwelling unit that conforms to this subdivision shall be deemed to be an accessory use or an accessory building and shall not be considered to exceed the allowable density for the lot upon which it is located, and shall be deemed to be a residential use that is consistent with the existing general plan and zoning designations for the lot. The accessory dwelling unit shall not be considered in the application of any local ordinance, policy, or program to limit residential growth.

(b) When a local agency that has not adopted an ordinance governing accessory dwelling units in accordance with subdivision (a) receives an application for a permit to create an accessory dwelling unit pursuant to this subdivision, the local agency shall approve or disapprove the application ministerially without discretionary review pursuant to subdivision (a). The permitting agency shall act on the application to create an accessory dwelling unit or a junior accessory dwelling unit within 60 days from the date the local agency receives a completed application if there is an existing single-family or multifamily dwelling on the lot. If the permit application to create an accessory dwelling unit or a junior accessory dwelling unit is submitted with a permit application to create a new single-family dwelling on the lot, the permitting agency may delay acting on the permit application for the accessory dwelling unit or the junior accessory dwelling unit until the permitting agency acts on the permit application to create the new single-family dwelling, but the application to create the accessory dwelling unit or junior accessory dwelling unit shall still be considered ministerially without discretionary review or a hearing. If the applicant requests a

delay, the 60-day time period shall be tolled for the period of the delay. If the local agency has not acted upon the completed application within 60 days, the application shall be deemed approved.

(c) (1) Subject to paragraph (2), a local agency may establish minimum and maximum unit size requirements for both attached and detached accessory dwelling units.

(2) Notwithstanding paragraph (1), a local agency shall not establish by ordinance any of the following:

(A) A minimum square footage requirement for either an attached or detached accessory dwelling unit that prohibits an efficiency unit.

(B) A maximum square footage requirement for either an attached or detached accessory dwelling unit that is less than either of the following:

(i) 850 square feet.

(ii) 1,000 square feet for an accessory dwelling unit that provides more than one bedroom.

(C) Any other minimum or maximum size for an accessory dwelling unit, size based upon a percentage of the proposed or existing primary dwelling, or limits on lot coverage, floor area ratio, open space, and minimum lot size, for either attached or detached dwellings that does not permit at least an 800 square foot accessory dwelling unit that is at least 16 feet in height with four-foot side and rear yard setbacks to be constructed in compliance with all other local development standards.

(d) Notwithstanding any other law, a local agency, whether or not it has adopted an ordinance governing accessory dwelling units in accordance with subdivision (a), shall not impose parking standards for an accessory dwelling unit in any of the following instances:

(1) The accessory dwelling unit is located within one-half mile walking distance of public transit.

(2) The accessory dwelling unit is located within an architecturally and historically significant historic district.

(3) The accessory dwelling unit is part of the proposed or existing primary residence or an accessory structure.

(4) When on-street parking permits are required but not offered to the occupant of the accessory dwelling unit.

(5) When there is a car share vehicle located within one block of the accessory dwelling unit.

(e) (1) Notwithstanding subdivisions (a) to (d), inclusive, a local agency shall ministerially approve an application for a building permit within a residential or mixed-use zone to create any of the following:

(A) One accessory dwelling unit or junior accessory dwelling unit per lot with a proposed or existing single-family dwelling if all of the following apply:

(i) The accessory dwelling unit or junior accessory dwelling unit is within the proposed space of a single-family dwelling or existing space of a single-family dwelling or accessory structure and may include an expansion of not more than 150 square feet beyond the same physical dimensions as the existing accessory structure.

An expansion beyond the physical dimensions of the existing accessory structure shall be limited to accommodating ingress and egress.

(ii) The space has exterior access from the proposed or existing single-family dwelling.

(iii) The side and rear setbacks are sufficient for fire and safety.

(iv) The junior accessory dwelling unit complies with the requirements of Section 65852.22.

(B) One detached, new construction, accessory dwelling unit that does not exceed four-foot side and rear yard setbacks for a lot with a proposed or existing single-family dwelling. The accessory dwelling unit may be combined with a junior accessory dwelling unit described in subparagraph (A). A local agency may impose the following conditions on the accessory dwelling unit:

(i) A total floor area limitation of not more than 800 square feet.

(ii) A height limitation of 16 feet.

(C) (i) Multiple accessory dwelling units within the portions of existing multifamily dwelling structures that are not used as livable space, including, but not limited to, storage rooms, boiler rooms, passageways, attics, basements, or garages, if each unit complies with state building standards for dwellings.

(ii) A local agency shall allow at least one accessory dwelling unit within an existing multifamily dwelling and shall allow up to 25 percent of the existing multifamily dwelling units.

(D) Not more than two accessory dwelling units that are located on a lot that has an existing multifamily dwelling, but are detached from that multifamily dwelling and are subject to a height limit of 16 feet and four-foot rear yard and side setbacks.

(2) A local agency shall not require, as a condition for ministerial approval of a permit application for the creation of an accessory dwelling unit or a junior accessory dwelling unit, the correction of nonconforming zoning conditions.

(3) The installation of fire sprinklers shall not be required in an accessory dwelling unit if sprinklers are not required for the primary residence.

(4) A local agency shall require that a rental of the accessory dwelling unit created pursuant to this subdivision be for a term longer than 30 days.

(5) A local agency may require, as part of the application for a permit to create an accessory dwelling unit connected to an onsite water treatment system, a percolation test completed within the last five years, or, if the percolation test has been recertified, within the last 10 years.

(6) Notwithstanding subdivision (c) and paragraph (1) a local agency that has adopted an ordinance by July 1, 2018, providing for the approval of accessory dwelling units in multifamily dwelling structures shall ministerially consider a permit application to construct an accessory dwelling unit that is described in paragraph (1), and may impose standards including, but not limited to, design, development, and historic standards on said accessory dwelling units. These standards shall not include requirements on minimum lot size.

(f) (1) Fees charged for the construction of accessory dwelling units shall be determined in accordance with Chapter 5 (commencing with Section 66000) and Chapter 7 (commencing with Section 66012).

(2) An accessory dwelling unit shall not be considered by a local agency, special district, or water corporation to be a new residential use for purposes of calculating connection fees or capacity charges for utilities, including water and sewer service, unless the accessory dwelling unit was constructed with a new single-family dwelling.

(3) (A) A local agency, special district, or water corporation shall not impose any impact fee upon the development of an accessory dwelling unit less than 750 square feet. Any impact fees charged for an accessory dwelling unit of 750 square feet or more shall be charged proportionately in relation to the square footage of the primary dwelling unit.

(B) For purposes of this paragraph, “impact fee” has the same meaning as the term “fee” is defined in subdivision (b) of Section 66000, except that it also includes fees specified in Section 66477. “Impact fee” does not include any connection fee or capacity charge charged by a local agency, special district, or water corporation.

(4) For an accessory dwelling unit described in subparagraph (A) of paragraph (1) of subdivision (e), a local agency, special district, or water corporation shall not require the applicant to install a new or separate utility connection directly between the accessory dwelling unit and the utility or impose a related connection fee or capacity charge, unless the accessory dwelling unit was constructed with a new single-family home.

(5) For an accessory dwelling unit that is not described in subparagraph (A) of paragraph (1) of subdivision (e), a local agency, special district, or water corporation may require a new or separate utility connection directly between the accessory dwelling unit and the utility. Consistent with Section 66013, the connection may be subject to a connection fee or capacity charge that shall be proportionate to the burden of the proposed accessory dwelling unit, based upon either its square feet or the number of its drainage fixture unit (DFU) values, as defined in the Uniform Plumbing Code adopted and published by the International Association of Plumbing and Mechanical Officials, upon the water or sewer system. This fee or charge shall not exceed the reasonable cost of providing this service.

(g) This section does not limit the authority of local agencies to adopt less restrictive requirements for the creation of an accessory dwelling unit.

(h) (1) A local agency shall submit a copy of the ordinance adopted pursuant to subdivision (a) to the Department of Housing and Community Development within 60 days after adoption. After adoption of an ordinance, the department may submit written findings to the local agency as to whether the ordinance complies with this section.

(2) (A) If the department finds that the local agency’s ordinance does not comply with this section, the department shall notify the local agency and shall provide the local agency with a reasonable time, no longer than 30 days, to respond to the findings before taking any other action authorized by this section.

(B) The local agency shall consider the findings made by the department pursuant to subparagraph (A) and shall do one of the following:

(i) Amend the ordinance to comply with this section.

(ii) Adopt the ordinance without changes. The local agency shall include findings in its resolution adopting the ordinance that explain the reasons the local agency believes that the ordinance complies with this section despite the findings of the department.

(3) (A) If the local agency does not amend its ordinance in response to the department's findings or does not adopt a resolution with findings explaining the reason the ordinance complies with this section and addressing the department's findings, the department shall notify the local agency and may notify the Attorney General that the local agency is in violation of state law.

(B) Before notifying the Attorney General that the local agency is in violation of state law, the department may consider whether a local agency adopted an ordinance in compliance with this section between January 1, 2017, and January 1, 2020.

(i) The department may review, adopt, amend, or repeal guidelines to implement uniform standards or criteria that supplement or clarify the terms, references, and standards set forth in this section. The guidelines adopted pursuant to this subdivision are not subject to Chapter 3.5 (commencing with Section 11340) of Part 1 of Division 3 of Title 2.

(j) As used in this section, the following terms mean:

(1) "Accessory dwelling unit" means an attached or a detached residential dwelling unit that provides complete independent living facilities for one or more persons and is located on a lot with a proposed or existing primary residence. It shall include permanent provisions for living, sleeping, eating, cooking, and sanitation on the same parcel as the single-family or multifamily dwelling is or will be situated. An accessory dwelling unit also includes the following:

(A) An efficiency unit.

(B) A manufactured home, as defined in Section 18007 of the Health and Safety Code.

(2) "Accessory structure" means a structure that is accessory and incidental to a dwelling located on the same lot.

(3) "Efficiency unit" has the same meaning as defined in Section 17958.1 of the Health and Safety Code.

(4) "Living area" means the interior habitable area of a dwelling unit, including basements and attics, but does not include a garage or any accessory structure.

(5) "Local agency" means a city, county, or city and county, whether general law or chartered.

(6) "Neighborhood" has the same meaning as set forth in Section 65589.5.

(7) "Nonconforming zoning condition" means a physical improvement on a property that does not conform with current zoning standards.

(8) "Passageway" means a pathway that is unobstructed clear to the sky and extends from a street to one entrance of the accessory dwelling unit.

(9) “Proposed dwelling” means a dwelling that is the subject of a permit application and that meets the requirements for permitting.

(10) “Public transit” means a location, including, but not limited to, a bus stop or train station, where the public may access buses, trains, subways, and other forms of transportation that charge set fares, run on fixed routes, and are available to the public.

(11) “Tandem parking” means that two or more automobiles are parked on a driveway or in any other location on a lot, lined up behind one another.

(k) A local agency shall not issue a certificate of occupancy for an accessory dwelling unit before the local agency issues a certificate of occupancy for the primary dwelling.

(l) Nothing in this section shall be construed to supersede or in any way alter or lessen the effect or application of the California Coastal Act of 1976 (Division 20 (commencing with Section 30000) of the Public Resources Code), except that the local government shall not be required to hold public hearings for coastal development permit applications for accessory dwelling units.

(m) A local agency may count an accessory dwelling unit for purposes of identifying adequate sites for housing, as specified in subdivision (a) of Section 65583.1, subject to authorization by the department and compliance with this division.

(n) In enforcing building standards pursuant to Article 1 (commencing with Section 17960) of Chapter 5 of Part 1.5 of Division 13 of the Health and Safety Code for an accessory dwelling unit described in paragraph (1) or (2) below, a local agency, upon request of an owner of an accessory dwelling unit for a delay in enforcement, shall delay enforcement of a building standard, subject to compliance with Section 17980.12 of the Health and Safety Code:

(1) The accessory dwelling unit was built before January 1, 2020.

(2) The accessory dwelling unit was built on or after January 1, 2020, in a local jurisdiction that, at the time the accessory dwelling unit was built, had a noncompliant accessory dwelling unit ordinance, but the ordinance is compliant at the time the request is made.

(o) This section shall remain in effect only until January 1, 2025, and as of that date is repealed.

(Amended by Stats. 2019, Ch. 659, Sec. 1.5. (AB 881) Effective January 1, 2020. Repealed as of January 1, 2025, by its own provisions. See later operative version added by Sec. 2.5 of Stats. 2019, Ch. 659.)

State of California

GOVERNMENT CODE

Section 65852.22

65852.22. (a) Notwithstanding Section 65852.2, a local agency may, by ordinance, provide for the creation of junior accessory dwelling units in single-family residential zones. The ordinance may require a permit to be obtained for the creation of a junior accessory dwelling unit, and shall do all of the following:

(1) Limit the number of junior accessory dwelling units to one per residential lot zoned for single-family residences with a single-family residence built, or proposed to be built, on the lot.

(2) Require owner-occupancy in the single-family residence in which the junior accessory dwelling unit will be permitted. The owner may reside in either the remaining portion of the structure or the newly created junior accessory dwelling unit. Owner-occupancy shall not be required if the owner is another governmental agency, land trust, or housing organization.

(3) Require the recordation of a deed restriction, which shall run with the land, shall be filed with the permitting agency, and shall include both of the following:

(A) A prohibition on the sale of the junior accessory dwelling unit separate from the sale of the single-family residence, including a statement that the deed restriction may be enforced against future purchasers.

(B) A restriction on the size and attributes of the junior accessory dwelling unit that conforms with this section.

(4) Require a permitted junior accessory dwelling unit to be constructed within the walls of the proposed or existing single-family residence.

(5) Require a permitted junior accessory dwelling to include a separate entrance from the main entrance to the proposed or existing single-family residence.

(6) Require the permitted junior accessory dwelling unit to include an efficiency kitchen, which shall include all of the following:

(A) A cooking facility with appliances.

(B) A food preparation counter and storage cabinets that are of reasonable size in relation to the size of the junior accessory dwelling unit.

(b) (1) An ordinance shall not require additional parking as a condition to grant a permit.

(2) This subdivision shall not be interpreted to prohibit the requirement of an inspection, including the imposition of a fee for that inspection, to determine if the junior accessory dwelling unit complies with applicable building standards.

(c) An application for a permit pursuant to this section shall, notwithstanding Section 65901 or 65906 or any local ordinance regulating the issuance of variances or special use permits, be considered ministerially, without discretionary review or a

hearing. The permitting agency shall act on the application to create a junior accessory dwelling unit within 60 days from the date the local agency receives a completed application if there is an existing single-family dwelling on the lot. If the permit application to create a junior accessory dwelling unit is submitted with a permit application to create a new single-family dwelling on the lot, the permitting agency may delay acting on the permit application for the junior accessory dwelling unit until the permitting agency acts on the permit application to create the new single-family dwelling, but the application to create the junior accessory dwelling unit shall still be considered ministerially without discretionary review or a hearing. If the applicant requests a delay, the 60-day time period shall be tolled for the period of the delay. A local agency may charge a fee to reimburse the local agency for costs incurred in connection with the issuance of a permit pursuant to this section.

(d) For purposes of any fire or life protection ordinance or regulation, a junior accessory dwelling unit shall not be considered a separate or new dwelling unit. This section shall not be construed to prohibit a city, county, city and county, or other local public entity from adopting an ordinance or regulation relating to fire and life protection requirements within a single-family residence that contains a junior accessory dwelling unit so long as the ordinance or regulation applies uniformly to all single-family residences within the zone regardless of whether the single-family residence includes a junior accessory dwelling unit or not.

(e) For purposes of providing service for water, sewer, or power, including a connection fee, a junior accessory dwelling unit shall not be considered a separate or new dwelling unit.

(f) This section shall not be construed to prohibit a local agency from adopting an ordinance or regulation, related to parking or a service or a connection fee for water, sewer, or power, that applies to a single-family residence that contains a junior accessory dwelling unit, so long as that ordinance or regulation applies uniformly to all single-family residences regardless of whether the single-family residence includes a junior accessory dwelling unit.

(g) If a local agency has not adopted a local ordinance pursuant to this section, the local agency shall ministerially approve a permit to construct a junior accessory dwelling unit that satisfies the requirements set forth in subparagraph (A) of paragraph (1) of subdivision (e) of Section 65852.2 and the requirements of this section.

(h) For purposes of this section, the following terms have the following meanings:

(1) “Junior accessory dwelling unit” means a unit that is no more than 500 square feet in size and contained entirely within a single-family residence. A junior accessory dwelling unit may include separate sanitation facilities, or may share sanitation facilities with the existing structure.

(2) “Local agency” means a city, county, or city and county, whether general law or chartered.

(Amended by Stats. 2019, Ch. 655, Sec. 2. (AB 68) Effective January 1, 2020.)

State of California

HEALTH AND SAFETY CODE

Section 18007

18007. (a) “Manufactured home,” for the purposes of this part, means a structure that was constructed on or after June 15, 1976, is transportable in one or more sections, is eight body feet or more in width, or 40 body feet or more in length, in the traveling mode, or, when erected on site, is 320 or more square feet, is built on a permanent chassis and designed to be used as a single-family dwelling with or without a foundation when connected to the required utilities, and includes the plumbing, heating, air conditioning, and electrical systems contained therein. “Manufactured home” includes any structure that meets all the requirements of this paragraph except the size requirements and with respect to which the manufacturer voluntarily files a certification and complies with the standards established under the National Manufactured Housing Construction and Safety Act of 1974 (42 U.S.C., Sec. 5401, and following).

(b) Notwithstanding any other provision of law, if a codified provision of state law uses the term “manufactured home,” and it clearly appears from the context that the term “manufactured home” should apply only to manufactured homes, as defined under subdivision (a), the codified provision shall apply only to those manufactured homes. If any codified provision of state law, by its context, requires that the term applies to manufactured homes or mobilehomes without regard to the date of construction, the codified provision shall apply to both manufactured homes, as defined under subdivision (a), and mobilehomes as defined under Section 18008.

(Amended by Stats. 2007, Ch. 540, Sec. 4. Effective January 1, 2008.)