



AGENDA

CAPITOLA PLANNING COMMISSION

Thursday, November 5, 2020 – 7:00 PM

Chairperson Ed Newman
Commissioners Courtney Christiansen
Mick Routh
TJ Welch
Peter Wilk

NOTICE OF REMOTE ACCESS ONLY:

In accordance with the current Order from Santa Cruz County Health Services and Executive Order regarding social distancing, the Planning Commission meeting will not be physically open to the public and in person attendance cannot be accommodated.

To watch:

1. Online <http://capitolaca.igam2.com/Citizens/Default.aspx>
2. Spectrum Cable Television channel 8
3. Zoom Meeting (link and phone numbers below)

To participate remotely and make public comment:

1. Send email:
 - a. As always, send additional materials to the Planning Commission via planningcommission@ci.capitola.ca.us by 5 p.m. the Wednesday before the meeting and they will be distributed to agenda recipients.
 - b. During the meeting, send comments via email to publiccomment@ci.capitola.ca.us
 - Identify the item you wish to comment on in your email's subject line. Emailed comments will be accepted during the Public Comments meeting item and for General Government / Public Hearing items.
 - Emailed comments on each General Government/ Public Hearing item will be accepted after the start of the meeting until the Chairman announces that public comment for that item is closed.
 - Emailed comments should be a maximum of 450 words, which corresponds to approximately 3 minutes of speaking time.
 - Each emailed comment will be read aloud for up to three minutes and/or displayed on a screen.
 - Emails received by publiccomment@ci.capitola.ca.us outside of the comment period outlined above will not be included in the record.
2. Zoom Meeting (Via Computer or Phone)
 - a. Please click the link below to join the meeting:
 - <https://us02web.zoom.us/j/87968524994?pwd=NIY2SmtPZktnMXd2MUI0N215bks3QT09> (link is external)
 - If prompted for a password, enter 694466
 - Use participant option to "raise hand" during the public comment period for the item you wish to speak on. Once unmuted, you will have up to 3 minutes to speak
 - b. Dial in with phone:

- Before the start of the item you wish to comment on, call any of the numbers below. If one is busy, try the next one
- **1 669 900 6833**
- **1 408 638 0968**
- **1 346 248 7799**
- **1 253 215 8782**
- **1 301 715 8592**
- **1 312 626 6799**
- **1 646 876 9923**
- Enter the meeting ID number: **879 6852 4994**
- When prompted for a Participant ID, press #
- Press *6 on your phone to “raise your hand” when the Chairman calls for public comment. It will be your turn to speak when the Chairman unmutes you. You will hear an announcement that you have been unmuted. The timer will then be set to 3 minutes.

REGULAR MEETING OF THE PLANNING COMMISSION - 7 PM

All correspondences received prior to 5:00 p.m. on the Wednesday preceding a Planning Commission Meeting will be distributed to Commissioners to review prior to the meeting. Information submitted after 5 p.m. on that Wednesday may not have time to reach Commissioners, nor be read by them prior to consideration of an item.

All matters listed on the Regular Meeting of the Capitola Planning Commission Agenda shall be considered as Public Hearings.

1. ROLL CALL AND PLEDGE OF ALLEGIANCE

2. ORAL COMMUNICATIONS

A. Additions and Deletions to Agenda

B. Public Comments

Short communications from the public concerning matters not on the Agenda. All speakers are requested to print their name on the sign-in sheet located at the podium so that their name may be accurately recorded in the Minutes.

C. Commission Comments

D. Staff Comments

3. APPROVAL OF MINUTES

A. Planning Commission - Regular Meeting - Oct 1, 2020 7:00 PM

4. CONSENT CALENDAR

All matters listed under "Consent Calendar" are considered by the Planning Commission to be routine and will be enacted by one motion in the form listed below. There will be no separate discussion on these items prior to the time the Planning Commission votes on the action unless members of the public or the Planning Commission request specific items to be discussed for separate review. Items pulled for separate discussion will be considered in the order listed on the Agenda.

A. **201 Esplanade** **#19-0371** **APN: 035-211-05**

Sign Permit for a wall sign for Tacos Moreno restaurant located within the CV (Central Village) zoning district.

This project is in the Coastal Zone but does not require a Coastal Development Permit.

Environmental Determination: Categorical Exemption

Owner: Michael Brosky

Representative: Gabriela Castro, Filed: 08.07.19

B. **Capitola Village Bollards** **#20-0398** **N/A**

REQUEST TO CONTINUE - Coastal Development Permit for the installation of anchors for 15 removable bollards/security barriers at three priority intersections within Capitola Village located within the C-V (Central Village) zoning district.

This project is in the Coastal Zone and requires a Coastal Development Permit.

Environmental Determination: Categorical Exemption

Property Owner: City of Capitola

Representative: Kailash Mozumder, City of Capitola, Filed: 09.25.2020

5. PUBLIC HEARINGS

Public Hearings are intended to provide an opportunity for public discussion of each item listed as a Public Hearing. The following procedure is as follows: 1) Staff Presentation; 2) Public Discussion; 3) Planning Commission Comments; 4) Close public portion of the Hearing; 5) Planning Commission Discussion; and 6) Decision.

A. 1360 41st Avenue**#20-0359****APN: 034-101-16**

Design Permit and Conditional Use Permit for a mixed-use development adding two new residential units within an existing commercial structure located within the C-C (Community Commercial) zoning district.

This project is in the Coastal Zone but does not require a Coastal Development Permit.

Environmental Determination: Categorical Exemption

Property Owner: Santa Cruz Beach, LLC

Representative: Steven Allen, Filed: 08.31.2020

B. Grand Avenue Pathway Improvements**#20-0395**

Coastal Development Permit (CDP) for drainage improvements between Oakland and Hollister Avenues on the Grand Avenue Pathway in front of 100 Oakland Avenue and 404 Grand Avenue in the R-1 (Single-Family Residential) Zoning District.

This project is in the Coastal Zone and requires a Coastal Development Permit which is appealable to the California Coastal Commission after all possible appeals are exhausted through the City. Work was completed under an Emergency CDP.

Environmental Determination: Categorical Exemption

Property Owners: City of Capitola

Representative: John David, Filed: 09.23.20

6. DIRECTOR'S REPORT**7. COMMISSION COMMUNICATIONS****8. ADJOURNMENT**

APPEALS: The following decisions of the Planning Commission can be appealed to the City Council within the (10) calendar days following the date of the Commission action: Conditional Use Permit, Variance, and Coastal Permit. The decision of the Planning Commission pertaining to an Architectural and Site Review Design Permit can be appealed to the City Council within the (10) working days following the date of the Commission action. If the tenth day falls on a weekend or holiday, the appeal period is extended to the next business day.

All appeals must be in writing, setting forth the nature of the action and the basis upon which the action is considered to be in error, and addressed to the City Council in care of the City Clerk. An appeal must be accompanied by a five hundred dollar (\$500) filing fee, unless the item involves a Coastal Permit that is appealable to the Coastal Commission, in which case there is no fee. If you challenge a decision of the Planning Commission in court, you may be limited to raising only those issues you or someone else raised at the public hearing described in this agenda, or in written correspondence delivered to the City at, or prior to, the public hearing.

Notice regarding Planning Commission meetings: The Planning Commission meets regularly on the 1st Thursday of each month at 7 p.m. in the City Hall Council Chambers located at 420 Capitola Avenue, Capitola.

Agenda and Agenda Packet Materials: The Planning Commission Agenda and complete Agenda Packet are available on the Internet at the City's website: www.cityofcapitola.org. Need more information? Contact the Community Development Department at (831) 475-7300.

Agenda Materials Distributed after Distribution of the Agenda Packet: Materials that are a public record under Government Code § 54957.5(A) and that relate to an agenda item of a regular meeting of the Planning Commission that are distributed to a majority of all the members of the Planning Commission more than 72 hours prior to that meeting shall be available for public inspection at City Hall located at 420 Capitola Avenue, Capitola, during normal business hours.

Americans with Disabilities Act: Disability-related aids or services are available to enable persons with a disability to participate in this meeting consistent with the Federal Americans with Disabilities Act of 1990. Assisted listening devices are available for individuals with hearing impairments at the meeting in the City Council Chambers. Should you require special accommodations to participate in the meeting due to a disability, please contact the Community Development Department at least 24 hours in advance of the meeting at (831) 475-7300. In an effort to accommodate individuals with environmental sensitivities, attendees are requested to refrain from wearing perfumes and other scented products.

Televised Meetings: Planning Commission meetings are cablecast "Live" on Charter Communications Cable TV Channel 8 and are recorded to be replayed on the following Monday and Friday at 1:00 p.m. on Charter Channel 71 and Comcast Channel 25. Meetings can also be viewed from the City's website: www.cityofcapitola.org.



**FINAL MINUTES
CAPITOLA PLANNING COMMISSION MEETING
THURSDAY, OCTOBER 1, 2020
7 P.M. – CAPITOLA CITY COUNCIL CHAMBERS**

1. ROLL CALL AND PLEDGE OF ALLEGIANCE

Commissioners Routh, Wilk, Christiansen, Welch, and Chair Newman were present.

2. ORAL COMMUNICATIONS

A. Additions and Deletions to Agenda

B. Public Comments

C. Commission Comments

Commissioner Routh asked for the status of the palm tree removal on Monterey Ave. Planner Sesanto answered that PG&E has been working on other priorities and the project has been delayed.

Chair Newman asked about a sign violation and a taqueria that was blocking a walkway with their tables.

D. Staff Comments

3. APPROVAL OF MINUTES

A. Planning Commission - Regular Meeting - May 7, 2020 7:00 PM

MOTION: Approve the minutes.

RESULT:	ACCEPTED [UNANIMOUS]
MOVER:	Peter Wilk
SECONDER:	Courtney Christiansen
AYES:	Newman, Welch, Wilk, Routh, Christiansen

4. CONSENT CALENDAR

A. 606 Escalona Drive #20-0355 APN: 036-141-25

Design Permit for second-story additions to a nonconforming two-story single-family residence located within the R-1 (Single-Family Residential) zoning district. This project is in the Coastal Zone but does not require a Coastal Development Permit. Environmental Determination: Categorical Exemption
Property Owner: Gary Lew
Representative: Eric Iverson – Fuse Architects, Filed: 09.02.2020

MOTION: Approve the Design Permit with the following conditions and findings.

Minutes Acceptance: Minutes of Oct 1, 2020 7:00 PM (Approval of Minutes)

CONDITIONS:

1. The project approval consists of construction of 28-square-feet of second-story additions to an existing nonconforming single-family residence. The maximum Floor Area Ratio for the 2,993-square-foot property is 57% (1,706 square feet). The total FAR of the project is 56.9% with a total of 1,704 square feet, compliant with the maximum FAR within the zone. The proposed project is approved as indicated on the final plans reviewed and approved by the Planning Commission on October 1, 2020, except as modified through conditions imposed by the Planning Commission during the hearing.
2. Prior to construction, a building permit shall be secured for any new construction or modifications to structures authorized by this permit. Final building plans shall be consistent with the plans approved by the Planning Commission. All construction and site improvements shall be completed according to the approved plans
3. At time of submittal for building permit review, the Conditions of Approval must be printed in full on the cover sheet of the construction plans.
4. At time of submittal for building permit review, Public Works Standard Detail SMP STRM shall be printed in full and incorporated as a sheet into the construction plans. All construction shall be done in accordance with the Public Works Standard Detail BMP STRM.
5. Prior to making any changes to approved plans, modifications must be specifically requested and submitted in writing to the Community Development Department. Any significant changes to the size or exterior appearance of the structure shall require Planning Commission approval.
6. Prior to issuance of building permit, a landscape plan shall be submitted and approved by the Community Development Department. The landscape plan can be produced by the property owner, landscape professional, or landscape architect. Landscape plans shall reflect the Planning Commission approval and shall identify type, size, and location of species and details of any proposed (but not required) irrigation systems.
7. Prior to issuance of building permit, all Planning fees associated with permit #20-0355 shall be paid in full.
8. Prior to issuance of building permit, the developer shall pay Affordable housing in-lieu fees as required to assure compliance with the City of Capitola Affordable (Inclusionary) Housing Ordinance.
9. Prior to issuance of a building permit, the applicant must provide documentation of plan approval by the following entities: Santa Cruz County Sanitation Department, Soquel Creek Water District, and Central Fire Protection District.
10. Prior to issuance of building permits, a drainage plan, grading, sediment and erosion control plan, shall be submitted to the City and approved by Public Works. The plans shall be in compliance with the requirements specified in Capitola Municipal Code Chapter 13.16 Storm Water Pollution Prevention and Protection.
11. Prior to issuance of building permits, the applicant shall submit a stormwater management plan to the satisfaction of the Director of Public Works which implements all applicable Post

Construction Requirements (PCRs) and Public Works Standard Details, including all standards relating to low impact development (LID).

12. Prior to any land disturbance, a pre-site inspection must be conducted by the grading official to verify compliance with the approved erosion and sediment control plan.
13. Prior to any work in the City road right of way, an encroachment permit shall be acquired by the contractor performing the work. No material or equipment storage may be placed in the road right-of-way.
14. During construction, any construction activity shall be subject to a construction noise curfew, except when otherwise specified in the building permit issued by the City. Construction noise shall be prohibited between the hours of nine p.m. and seven-thirty a.m. on weekdays. Construction noise shall be prohibited on weekends with the exception of Saturday work between nine a.m. and four p.m. or emergency work approved by the building official. §9.12.010B
15. Prior to a project final, all cracked or broken driveway approaches, curb, gutter, or sidewalk shall be replaced per the Public Works Standard Details and to the satisfaction of the Public Works Department. All replaced driveway approaches, curb, gutter or sidewalk shall meet current Accessibility Standards.
16. Prior to issuance of a Certificate of Occupancy, compliance with all conditions of approval shall be demonstrated to the satisfaction of the Community Development Director. Upon evidence of non-compliance with conditions of approval or applicable municipal code provisions, the applicant shall remedy the non-compliance to the satisfaction of the Community Development Director or shall file an application for a permit amendment for Planning Commission consideration. Failure to remedy a non-compliance in a timely manner may result in permit revocation.
17. This permit shall expire 24 months from the date of issuance. The applicant shall have an approved building permit and construction underway before this date to prevent permit expiration. Applications for extension may be submitted by the applicant prior to expiration pursuant to Municipal Code section 17.81.160 (Coastal).
18. The planning and infrastructure review and approval are transferable with the title to the underlying property so that an approved project may be conveyed or assigned by the applicant to others without losing the approval. The permit cannot be transferred off the site on which the approval was granted.
19. Upon receipt of certificate of occupancy, garbage and recycling containers shall be placed out of public view on non-collection days.
20. Prior to issuance of building permits, the building plans must show that the existing overhead utility lines will be underground to the nearest utility pole.
21. Prior to issuance of building permits the applicant shall provide details of the existing sub-grade drainage system.

FINDINGS:

A. The project, subject to the conditions imposed, secures the purposes of the Zoning Ordinance, General Plan, and Local Coastal Plan.

Community Development Staff, the Architectural and Site Review Committee, and the Planning Commission have all reviewed the project. The proposed second-story additions comply with the development standards of the R-1 (Single-Family Residential) District. The project secures the purpose of the Zoning Ordinance, General Plan, and Local Coastal Plan

B. The project will maintain the character and integrity of the neighborhood.

Community Development Staff, the Architectural and Site Review Committee, and the Planning Commission have all reviewed the application for the second-story additions. The design of the home with board and batten siding and gabled roof will fit in nicely with the existing neighborhood. The project will maintain the character and integrity of the neighborhood.

CALIFORNIA ENVIRONMENTAL QUALITY ACT (CEQA) FINDINGS

A. This project is categorically exempt under Section 15301(e) of the California Environmental Quality Act and is subject to Section 753.5 of Title 14 of the California Code of Regulations.

Section 15301(e) of the CEQA Guidelines exempts additions to existing structures provided that the addition will not result in an increase of more than 50 percent of the floor area of the structures before the addition, or 2,500 square feet, whichever is less. The proposed additions add 28 square feet (1.7%) of floor area, so this exemption applies. No adverse environmental impacts were discovered during project review by Planning Department Staff

RESULT:	APPROVED [3 TO 0]
MOVER:	Peter Wilk
SECONDER:	Mick Routh
AYES:	Newman, Wilk, Routh
RECUSED:	Welch, Christiansen

B. 521 Riverview Drive #20-0050 APN: 035-042-10

Design Permit for a second-story addition to a two-story single-family residence located within the R-1 (Single-Family Residential) zoning district.

This project is in the Coastal Zone but does not require a Coastal Development Permit.

Environmental Determination: Categorical Exemption

Owner/Representative: Geno Benvenuto, Filed: 02.10.20

MOTION: Approve the Design Permit with the following conditions and findings.

CONDITIONS:

1. The project approval consists of construction of a 169-square-foot second-story addition. The maximum Floor Area Ratio for the 7,285-square-foot property is 48% (3,497 square feet). The total FAR of the project is 46.5% with a total of 3,394 square feet, compliant with the maximum FAR within the zone. The proposed project is approved as indicated on the final plans reviewed and approved by the Planning Commission on October 1, 2020, except as modified through conditions imposed by the Planning Commission during the hearing.

Minutes Acceptance: Minutes of Oct 1, 2020 7:00 PM (Approval of Minutes)

2. Prior to construction, a building permit shall be secured for any new construction or modifications to structures authorized by this permit. Final building plans shall be consistent with the plans approved by the Planning Commission. All construction and site improvements shall be completed according to the approved plans
3. At time of submittal for building permit review, the Conditions of Approval must be printed in full on the cover sheet of the construction plans.
4. At the time of submittal for building permit review, Public Works Standard Detail Storm Water Best Management Practices (STRM-BMP) shall be printed in full and incorporated as a sheet into the construction plans. All construction shall be done in accordance with Public Works Standard Detail Storm Water Best Management Practices (STRM-BMP).
5. Prior to making any changes to approved plans, modifications must be specifically requested and submitted in writing to the Community Development Department. Any significant changes to the size or exterior appearance of the structure shall require Planning Commission approval.
6. Prior to issuance of building permit, all Planning fees associated with permit #20-0050 shall be paid in full.
7. Prior to issuance of building permit, the developer shall pay Affordable housing in-lieu fees as required to assure compliance with the City of Capitola Affordable (Inclusionary) Housing Ordinance.
8. Prior to issuance of a building permit, the applicant must provide documentation of plan approval by the following entities: Santa Cruz County Sanitation Department, Soquel Creek Water District, and Central Fire Protection District.
9. Prior to issuance of building permits, a drainage plan, grading, sediment and erosion control plan, shall be submitted to the City and approved by Public Works. The plans shall be in compliance with the requirements specified in Capitola Municipal Code Chapter 13.16 Storm Water Pollution Prevention and Protection.
10. Prior to issuance of building permits, the applicant shall submit a stormwater management plan to the satisfaction of the Director of Public Works which implements all applicable Post Construction Requirements (PCRs) and Public Works Standard Details, including all standards relating to low impact development (LID).
11. Prior to any land disturbance, a pre-site inspection must be conducted by the grading official to verify compliance with the approved erosion and sediment control plan.
12. Prior to any work in the City road right of way, an encroachment permit shall be acquired by the contractor performing the work. No material or equipment storage may be placed in the road right-of-way.
13. During construction, any construction activity shall be subject to a construction noise curfew, except when otherwise specified in the building permit issued by the City. Construction noise shall be prohibited between the hours of nine p.m. and seven-thirty a.m. on weekdays. Construction noise shall be prohibited on weekends with the exception of Saturday work between nine a.m. and four p.m. or emergency work approved by the building official. §9.12.010B

14. Prior to a project final, all cracked or broken driveway approaches, curb, gutter, or sidewalk shall be replaced per the Public Works Standard Details and to the satisfaction of the Public Works Department. All replaced driveway approaches, curb, gutter or sidewalk shall meet current Accessibility Standards.
15. Prior to issuance of a Certificate of Occupancy, compliance with all conditions of approval shall be demonstrated to the satisfaction of the Community Development Director. Upon evidence of non-compliance with conditions of approval or applicable municipal code provisions, the applicant shall remedy the non-compliance to the satisfaction of the Community Development Director or shall file an application for a permit amendment for Planning Commission consideration. Failure to remedy a non-compliance in a timely manner may result in permit revocation.
16. This permit shall expire 24 months from the date of issuance. The applicant shall have an approved building permit and construction underway before this date to prevent permit expiration. Applications for extension may be submitted by the applicant prior to expiration pursuant to Municipal Code section 17.81.160.
17. The planning and infrastructure review and approval are transferable with the title to the underlying property so that an approved project may be conveyed or assigned by the applicant to others without losing the approval. The permit cannot be transferred off the site on which the approval was granted.
18. Upon receipt of certificate of occupancy, garbage and recycling containers shall be placed out of public view on non-collection days.
19. For new residential construction located within the floodplain/floodway, elevation certificates shall be provided at the following stages of construction: 1) prior to building permit issuance; 2) at the time of rough frame inspection; and prior to the finalization of the building permit. The certificates shall be prepared by a licensed engineer or surveyor. The certificate shall document that all residential occupancies are constructed above the Base Flood Elevation (BFE) as per the latest edition of the FEMA Flood Insurance Rate Map.

FINDINGS:

A. The project, subject to the conditions imposed, secures the purposes of the Zoning Ordinance, General Plan, and Local Coastal Plan.

Community Development Staff, the Architectural and Site Review Committee, and the Planning Commission have all reviewed the project. The proposed second-story addition complies with the development standards of the R-1 (Single Family Residential) District. The project secures the purpose of the Zoning Ordinance, General Plan, and Local Coastal Plan.

B. The project will maintain the character and integrity of the neighborhood.

Community Development Staff, the Architectural and Site Review Committee, and the Planning Commission have all reviewed the application for the second-story addition. The design of the home addition, with new slatwall panels and a new gabled roof, matches the existing design of the home, and will fit in nicely with the existing neighborhood. The project will maintain the character and integrity of the neighborhood.

CALIFORNIA ENVIRONMENTAL QUALITY ACT (CEQA) FINDINGS

A. This project is categorically exempt under Section 15301(e) of the California Environmental Quality Act and is subject to Section 753.5 of Title 14 of the California Code of Regulations.

Section 15301(e) of the CEQA Guidelines exempts additions to existing structures provided that the addition will not result in an increase of more than 50 percent of the floor area of the structures before the addition, or 2,500 square feet, whichever is less. The proposed addition will increase the floor area by 169 square feet (6.1%), so this exemption applies. No adverse environmental impacts were discovered during project review by Planning Department Staff.

RESULT:	APPROVED [UNANIMOUS]
MOVER:	Peter Wilk
SECONDER:	Mick Routh
AYES:	Newman, Welch, Wilk, Routh, Christiansen

5. PUBLIC HEARINGS

A. 1860 43rd Avenue #20-0356 APN: 034-122-18

Variance for a first-story patio encroachment into the required side yard setback for a two-story single-family residence located within the R-1 (Single-Family Residential) zoning district.

This project is in the Coastal Zone but does not require a Coastal Development Permit.

Environmental Determination: Categorical Exemption

Property Owner: Mike & Kristy Hughes

Representative: Mike & Kristy Hughes, Filed: 08.31.2020

Planner Orbach presented the staff report.

Chair Newman asked if the applicant was replacing the entire fence and Planner Orbach said yes.

Neighbor Debbie Hale said in public comment that they are not opposed to the patio location. Neighbor Andy Ward said any additional fencing is not necessary.

Commissioner Wilk agreed with the staff recommendation but is concerned about setting a precedent. He does not think there is a need for the fence addition.

Commissioner Routh agreed with Commissioner Wilk.

Commissioner Welch thanked the neighbors for being in support of the variance.

Commissioner Christiansen agreed with Commissioners Wilk and Welch.

Chair Newman thinks the variance is a good solution to this.

Commissioner Wilk asked Chair Newman if there would be a lawsuit against the City for the cost of the applicant's changes.

The special circumstance is that the patio was installed due to a City error during the review process.

Minutes Acceptance: Minutes of Oct 1, 2020 7:00 PM (Approval of Minutes)

Director Herlihy added that permits were issued to the applicants at no charge since it was an error by City Staff.

MOTION: Approve the Variance with the following conditions and findings.

CONDITIONS:

1. The project approval consists of a variance for a first-story patio encroachment into the required side yard setback for a two-story single-family residence. The proposed project is approved as indicated on the final plans reviewed and approved by the Planning Commission on October 1, 2020, except as modified through conditions imposed by the Planning Commission during the hearing.
2. Final building plans shall be consistent with the plans approved by the Planning Commission. All construction and site improvements shall be completed according to the approved plans.
3. Prior to making any changes to approved plans, modifications must be specifically requested and submitted in writing to the Community Development Department. Any significant changes to the size or exterior appearance of the structure shall require Planning Commission approval.
4. This permit shall expire 24 months from the date of issuance. The applicant shall have an approved building permit and construction underway before this date to prevent permit expiration. Applications for extension may be submitted by the applicant prior to expiration pursuant to Municipal Code section 17.81.160.
5. The planning and infrastructure review and approval are transferable with the title to the underlying property so that an approved project may be conveyed or assigned by the applicant to others without losing the approval. The permit cannot be transferred off the site on which the approval was granted.

VARIANCE FINDINGS:

- A. **Special circumstances applicable to the subject property, including size, shape, topography, location or surroundings, exist on the site and the strict application of this title is found to deprive subject property of privileges enjoyed by other properties in the vicinity and under identical zone classification;**
~~The subject property is relatively large by Capitola standards (6,316 square feet), regularly shaped, and flat. The special circumstance applicable to the subject property is that, at 60 feet wide, it is wider than the standard lot width of 40 feet for the majority of the lots on the street. The special circumstances applicable to the subject property are the City's error in approving a building permit that did not comply with the required side yard setback, the financial hardship of correcting the patio that was built within the side yard setback based on that error, and the lack of fire or safety concerns relating to the location of the patio that require correction.~~
- B. **The grant of a variance would not constitute a grant of a special privilege inconsistent with the limitation upon other properties in the vicinity and zone in which subject property is situated.**
 The majority of lots on 43rd Avenue have nonconforming residential structures that do not comply with side setback requirements. Staff utilized aerial images to access the existing

structures along the street relative to the setback requirements. From the aerial survey, the structures at 1858, 1863, 1853, 1843, 1820, 1814, 1788, 1799, 1789, 1791, 1854, 1755, 1736, 1730, 1731, and 1720 43rd Avenue all appear to be nonconforming in terms of compliance with side yard setbacks. Therefore, the granting of a variance to the side setback requirements would not constitute a grant special privilege inconsistent with the limitations upon other properties in the vicinity and zone in which the subject property is situated.

CALIFORNIA ENVIRONMENTAL QUALITY ACT (CEQA) FINDINGS

A. This project is categorically exempt under Section 15303(e) of the California Environmental Quality Act and is subject to Section 753.5 of Title 14 of the California Code of Regulations.

Section 15303(e) of the CEQA Guidelines exempts accessory (appurtenant) structures, including garages, carports, patios, swimming pools, and fences. The proposed project involves a raised concrete patio less than 30 inches in height. No adverse environmental impacts were discovered during review of the proposed project.

RESULT:	APPROVED [UNANIMOUS]
MOVER:	Peter Wilk
SECONDER:	Courtney Christiansen
AYES:	Newman, Welch, Wilk, Routh, Christiansen

B. Zoning Code Adoption and LCP Certification All Properties within Capitola

Update to the City of Capitola Zoning Code (Municipal Code Chapter 17) incorporating Coastal Commission staff edits in preparation for Local Coastal Program certification. The Zoning Code serves as the Implementation Plan of the City's Local Coastal Program and therefore must be certified by the Coastal Commission.

Environmental Determination: Addendum to the General Plan Update EIR

Property: The Zoning Code update affects all properties within the City of Capitola.

Representative: Katie Cattan, Community Development Director, City of Capitola

Director Herlihy presented the staff report.

Ben Noble presented Topics 5 and 6.

Commissioner Wilk asked for the definition of a rooftop deck. Director Herlihy said it would be the deck on the very top of the structure.

Commissioner Welch asked about public use and he couldn't find it in the coastal act. He also asked about shoreline processes.

Chair Newman asked Commissioner Welch if he wanted to set up a new public hearing and go over each issue one by one. Commissioner Welch does not wish to hold up this item if the rest of the commission approves of it.

Commissioner Wilk said we should approve it.

Commissioner Routh agrees with Commissioner Wilk but if individual commissioners have issues with it they should take those to the City Council.

MOTION: Approve the Update.

RESULT:	APPROVED [4 TO 1]
MOVER:	Peter Wilk
SECONDER:	Mick Routh
AYES:	Newman, Wilk, Routh, Christiansen
NAYS:	Welch

6. DIRECTOR'S REPORT

Director Herlihy presented the Director's Report.

The County of Santa Cruz has opened a grant opportunity to businesses in the county needing financial support because of COVID-19.

Director Herlihy gave an update on free temporary use agreements for businesses to move outdoors. Twenty-two permits were issued and will be continued until social distancing requirements are no longer in place.

The City Council reviewed the inclusionary housing ordinance.

The Coastal Commission certified the LCP amendments regarding signs and accessory dwelling units.

Commissioner Wilk asked about the outdoor seating in the walkway between Zelda's and the taqueria. Director Herlihy said that would not be allowed.

7. COMMISSION COMMUNICATIONS

8. ADJOURNED

The meeting was adjourned at 8:10 p.m. to the next regular meeting of the Planning Commission on November 5, 2020.

Liz Nichols, Clerk to the Commission



STAFF REPORT

TO: PLANNING COMMISSION
 FROM: COMMUNITY DEVELOPMENT
 DATE: NOVEMBER 5, 2020
 SUBJECT: **201 Esplanade** **#19-0371** **APN: 035-211-05**

Sign Permit for a wall sign for Tacos Moreno restaurant located within the CV (Central Village) zoning district.

This project is in the Coastal Zone but does not require a Coastal Development Permit.

Environmental Determination: Categorical Exemption

Owner: Michael Brosky

Representative: Gabriela Castro, Filed: 08.07.19

APPLICANT PROPOSAL

The applicant is proposing a new wall sign and menu box on the front of the building for Tacos Moreno located at 201 Esplanade in the CV (Central Village) Zoning District. The new wall sign requires Planning Commission approval of a sign permit.

BACKGROUND

In 2011, the City Council approved a Conditional Use Permit amendment for a previous tenant to include a to-go window.

In 2016, the Planning Commission approved a sign permit for two new awning signs on the front of the building.

The current application is the result of the installation of a wall signage without a permit. The current tenant removed and replaced the existing awnings with plain awnings with no logos or signage and installed a new wall sign and menu box.

DISCUSSION

Tacos Moreno is located at 201 Esplanade at the east end of the row of restaurants and bars closest to the beach. The application is for a wall sign and menu box to replace the previous two awning signs and a nonconforming menu box. The new wall sign is a non-illuminated, wooden sign with raised lettering. The wall sign measures two feet tall by sixteen feet in length, with a sign area of 32 square feet. The application also includes a new aluminum menu box measuring one-and-a-half feet tall by two feet in length, with an area of three square feet.

Pursuant to Section 17.57.070(B) of Capitola Municipal Code, wall signs are required to comply with the following underlined standards:

1. Each business shall be permitted only one wall sign.

Staff Analysis: The application includes one wall sign on the front façade of the building.

2. The size of each individual sign shall not be greater than one square foot of sign area for each one linear foot of business frontage.

Staff analysis: The business has approximately 40 linear feet of business frontage along the Esplanade. The wall sign is 32 square feet, below the maximum allowable wall sign size.

3. No such sign, including any light box or other structural part, shall project more than twelve inches from the building face.

Staff analysis: The proposed sign will have a maximum projection of three inches from the building face.

4. Wall signs shall be mounted parallel to the building, unless otherwise approved by the planning commission.

Staff analysis: The sign will be mounted parallel to the building face.

5. No part of any such sign shall extend above the top level of the wall upon or in front of which it is situated. Any such sign which is suspended or projects over any public walkway or walk area shall have an overhead clearance of at least eight feet. No permanent sign may be erected over any publicly dedicated walkway or street contrary to the building code.

Staff Analysis: The wall sign will be mounted directly to the wall. The sign is proposed on the first story above the front windows and below the roof eave.

6. No such sign shall list the products to be sold or the services to be provided by any business.

Staff Analysis: The sign includes the business name "Tacos Moreno" and a second line with "Burritos Quesadillas Tacos". The City cannot regulate the content of signs.

7. Menu Box. Pursuant to Section 17.57.060(D), Central Village restaurants are allowed one menu box that does not exceed three square feet.

Staff Analysis: The applicant is replacing a nonconforming menu box with a new three-square-foot menu box.

The proposed wall sign and menu box comply with all the required standards.

Awnings

The applicant removed the previous awning signs and replace with plain awnings with no signs. A condition has been added that the awnings be kept clean and appear in good condition.

CEQA REVIEW

Section 15311(a) of the CEQA Guidelines exempts the construction of on-premise commercial signs. This project involves one new wall sign for a restaurant. No adverse environmental impacts were discovered during review of the proposed project

RECOMMENDATION

Staff recommends the Planning Commission **approve** project application #19-0371 based on the following Conditions and Findings for Approval.

CONDITIONS

1. The project approval consists of a 32-square-foot wall sign and a three-square-foot menu box for Tacos Moreno at 201 Esplanade. The proposed project is approved as indicated on the final plans and photos and approved by the Planning Commission on November 5,

2020, except as modified through conditions imposed by the Planning Commission during the hearing.

2. The awnings must be kept clean and appear in good condition. Awnings are vulnerable to the natural elements and therefore the awnings shall be replaced by the owner when they show signs of wear.
3. Prior to making any changes to approved plans, modifications must be specifically requested and submitted in writing to the Community Development Department. Any significant changes shall require Planning Commission approval.
4. Prior to any work in the City road right of way, an encroachment permit shall be acquired by the contractor performing the work. No material or equipment storage may be placed in the road right-of-way.
5. Compliance with all conditions of approval shall be demonstrated to the satisfaction of the Community Development Director. Upon evidence of non-compliance with conditions of approval or applicable municipal code provisions, the applicant shall remedy the non-compliance to the satisfaction of the Community Development Director or shall file an application for a permit amendment for Planning Commission consideration. Failure to remedy a non-compliance in a timely manner may result in permit revocation.
6. A building permit shall be secured for any work authorized by this permit. Final building plans shall be consistent with the plans approved by the Planning Commission. All construction and site improvements shall be completed according to the approved plans.
7. This permit shall expire 24 months from the date of issuance. The applicant shall have an approved building permit and construction underway before this date to prevent permit expiration. Applications for extension may be submitted by the applicant prior to expiration pursuant to Municipal Code section 17.81.160.
8. The planning and infrastructure review and approval are transferable with the title to the underlying property so that an approved project may be conveyed or assigned by the applicant to others without losing the approval. The permit cannot be transferred off the site on which the approval was granted.

SIGN PERMIT FINDINGS

A. The application, subject to the conditions imposed, will secure the purposes of the Zoning Ordinance, General Plan, and Local Coastal Plan.

Community Development Department Staff and the Planning Commission have reviewed the sign application. The proposed wall sign secures the purposes of the Zoning Ordinance, General Plan, and Local Coastal Plan.

B. The application will maintain the character and integrity of the neighborhood.

Community Development Department Staff and the Planning Commission have reviewed the application and determined that the sign will maintain the character and integrity of the Central Village.

CALIFORNIA ENVIRONMENTAL QUALITY ACT (CEQA) FINDINGS

- A. **This project is categorically exempt under Section 15311(a) of the California Environmental Quality Act and is not subject to Section 753.5 of Title 14 of the California Code of Regulations.**

This project involves a new wall sign for a restaurant in the CV (Central Village) Zoning District. Section 15311(a) of the CEQA Guidelines exempts the construction of on-premise commercial signs.

ATTACHMENTS:

1. 201 Esplanade - Plan Set

Prepared By: Sean Sesanto

BENOTT

Site 1" = 10'

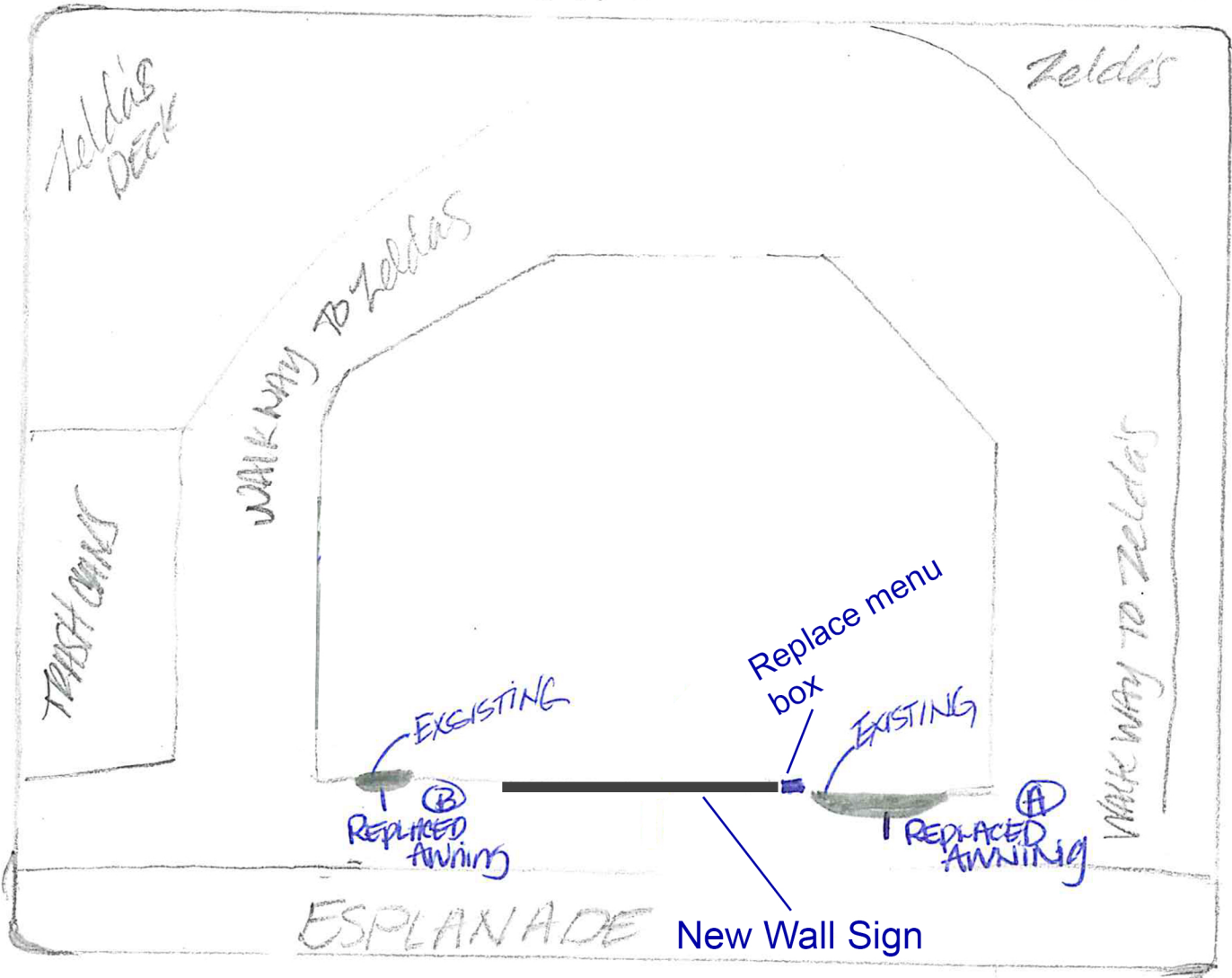

NEW SIGN WALL

* 12 concrete anchors holding

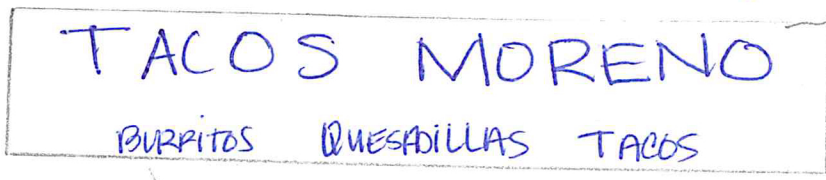

* ALL WOOD
 LETTER 6 in
 2ft+ GREY SIGN
 BLACK LETTERS



Attachment: 201 Esplanade - Plan Set (201 Esplanade)



STAFF REPORT

TO: PLANNING COMMISSION
FROM: COMMUNITY DEVELOPMENT
DATE: NOVEMBER 5, 2020
SUBJECT: **Capitola Village Bollards** **#20-0398** **N/A**

REQUEST TO CONTINUE - Coastal Development Permit for the installation of anchors for 15 removable bollards/security barriers at three priority intersections within Capitola Village located within the C-V (Central Village) zoning district. This project is in the Coastal Zone and requires a Coastal Development Permit. Environmental Determination: Categorical Exemption
Property Owner: City of Capitola
Representative: Kailash Mozumder, City of Capitola, Filed: 09.25.2020

RECOMMENDATION

Staff recommends the Planning Commission continue application #20-0398 to the December 3, 2020, Planning Commission meeting.

Prepared By: Matt Orbach
Associate Planner



STAFF REPORT

TO: PLANNING COMMISSION
 FROM: COMMUNITY DEVELOPMENT
 DATE: NOVEMBER 5, 2020
 SUBJECT: **1360 41st Avenue #20-0359 APN: 034-101-16**

Design Permit and Conditional Use Permit for a mixed-use development adding two new residential units within an existing commercial structure located within the C-C (Community Commercial) zoning district.

This project is in the Coastal Zone but does not require a Coastal Development Permit.

Environmental Determination: Categorical Exemption

Property Owner: Santa Cruz Beach, LLC

Representative: Steven Allen, Filed: 08.31.2020

APPLICANT PROPOSAL

The applicant is proposing a mixed-use development with two new residential units within an existing commercial structure. Multiple-family residences require a conditional use permit (CUP) within the C-C (Community Commercial) zoning district.

BACKGROUND

On October 14, 2020, the Architectural and Site Review Committee reviewed the application and provided the applicant with the following direction:

Public Works Representative, Danielle Uharriet: requested that two standard Public Works stormwater conditions be added to the conditions of approval.

Building Official, Robin Woodman: had no issues with the project.

Local Architect, Frank Phanton: stated that he appreciated the project design.

Associate Planner, Matt Orbach: informed the applicant that Fire Department approval of the proposed parking space encroachment into the vehicular right of way would be required prior to Planning Commission review of the project.

Following the Architecture & Site Review Committee Meeting, the applicant submitted Central Fire Protection District approval of the proposed parking space encroachment into the vehicular right of way.

Development Standards

The following table outlines the zoning code requirements for development in the C-C Zoning

District.

C-C (Community Commercial) Zoning District

Development Standards	Existing	Proposed
Use	Retail	Mixed Use: Retail/Office + Multi-Family Residential
Is Conditional Use Permit required?	No	Yes
Height: 40 ft. Maximum	20 ft.	20 ft.
Yards		
A. Landscaped areas of front yards shall be set back fifteen feet in accordance with the 41st Avenue design guidelines.		8 ft. 2 in. setback to front property line Existing Nonconforming 15 ft. of landscaping from sidewalk to building Existing Nonconforming
B. Side and rear yard setbacks may be required through architectural and site approval in order to provide adequate light and air, assure sufficient distance between adjoining uses to minimize any incompatibility and to promote excellence of development; except that where a side or rear yard is provided it shall be at least ten feet wide		9 ft. – North 2 ft. 2 in. – South Existing Nonconforming
C. Front yards and corner lot side yards shall not be used for required parking facilities.		Complies
Parking	Required	Proposed
Retail/Office- 1 space per 300 sq. ft. Duplex- 2 spaces per unit (1 covered space per unit)	Retail/Office = 10 spaces Duplex = 4 spaces (2 covered) Total = 14 spaces	9 spaces total 3 covered compact commercial spaces 1 van accessible stall Existing Nonconforming.
Landscaping. Five percent of the lot area shall be landscaped to ensure harmony with adjacent development in accordance with architectural and site approval standards		205 sq. ft. (2%) Existing Nonconforming
General Plan: Floor Area Ratio Allowance	CC – Maximum FAR of 1.0 (9,510 sq. ft.)	4,564 sq. ft. (0.479 FAR) - Complies
41st Avenue Design Guidelines	Proposal is aligned with all relevant guidelines	

DISCUSSION

The existing structure at 1360 41st Avenue is a nonconforming, two-story, commercial structure previously occupied by Hannah's Home Furnishing. The lot is in the 41st Avenue commercial corridor and is surrounded by one- and two-story commercial buildings. There is a large parking

area behind 1360 41st Avenue (Hannah's) that belongs to the parcels at 1408 41st Avenue (Helm) and the office building at 1350 41st Avenue. Access to the parking area is provided by two driveways, one off of 41st Avenue between 1360 41st Avenue and 1408 41st Avenue and one off of Jade Street at the rear of the office building at 1350 41st Avenue.

The applicant originally proposed one residential unit in the existing office area above the first-floor commercial space, but single-family residential units are not a permitted or conditional use in the C-C zoning district. Multiple-family residences, however, are a conditionally permitted use. Therefore, the current application is proposing to convert the existing second-story office space into two residential units. The project would not add any new floor area to the structure, and the only visible changes to the exterior of the building would be new larger second-story windows on the east elevation (rear) and a new opening on the north elevation providing access to the new stairway to the two upstairs residential units.

Conditional Use Permit

Under Capitola Municipal Code (CMC) §17.27.060(W), multiple-family residences are a conditional use in the C-C zoning district. The use may be permitted by the Planning Commission if the residential use is secondary to a principal permitted use on the same lot and subject to certain limitations. The application complies with the limitations as follows:

1. First floor uses shall be commercial uses;

Staff Analysis: The proposed project maintains the first floor for commercial uses, so the project complies.

2. Commercial ceiling height shall be greater in height than any residential ceiling height located above commercial uses,

Staff Analysis: The proposed project involves the conversion of existing floor area that does not change the ceiling heights of the existing structure. However, the existing first- and second-floor ceiling heights are both eight feet. Therefore, the structure does not comply with this limitation and is legal non-conforming.

3. First floor ceiling heights shall be a minimum of fifteen feet or one hundred twenty percent of the maximum ceiling height of the residential units located above the commercial uses, whichever is greater;

Staff Analysis: The first-floor ceiling height is eight feet. The proposed project involves a conversion of the existing structure that does not comply with this development standard and is legal non-conforming.

4. Commercial entrances shall be the primary building entries and shall be accented with strong architectural definition. Residential entrances shall be secondary and de-emphasized (e.g., located at the rear of the building, visually unobtrusive, etc.);

Staff Analysis: The proposed project maintains the primary building entry on the front façade facing 41st Avenue with strong architectural definition. The new residential entrances are secondary and de-emphasized, with locations on the side and rear of the building.

5. Adequate separation of different types of uses shall be maintained in order to avoid potential adverse impacts from one use on another due to noise, lighting, odors, vibration, and general nuisances;

Staff Analysis: The proposed project maintains separation of the commercial and residential use.

6. Adequate separation of different types of uses shall be maintained to protect the aesthetic values and primary uses of the site.

Staff Analysis: The proposed project provides adequate separation of the commercial and residential uses on the site and protects the aesthetic values and primary uses of the site.

Considerations

CMC §17.60.030(A) states that, “in considering an application for a conditional use, the planning commission shall give due regard to the nature and condition of all adjacent uses and structures.” Due to the limited size of the parking area behind the structure at 1360 41st Avenue and the close proximity of the large parking areas on the two adjacent parcels, the proposed project has the potential for adverse impacts on the availability of parking on the adjacent parcels. Parking is analyzed in the following section.

Parking

The proposed parking does not comply with the minimum number of required parking spaces, minimum parking space dimensions, or minimum covered parking space dimensions. However, pursuant to §17.51.135(A), because the proposed project does not add any new floor area or increase the intensity of the use by requiring more parking than is currently required, the nonconforming parking does not have to be brought into compliance.

The creation of a new residential use on the property, however, has the effect of reducing the number of available parking spaces for the under-parked existing commercial use, and could negatively affect the availability of parking on the adjacent parcels. Therefore, a parking study was conducted to analyze whether or not the nine proposed parking spaces at 1360 41st Avenue are adequate for the existing commercial use and the proposed residential use under a shared parking arrangement (Attachment 2).

The parking study, conducted by Kimley-Horn, utilized Institute of Transportation Engineers (ITE) parking generation rates to determine how many parking spaces are necessary for a shared parking area for the proposed commercial/residential mixed-use project. The study looked at two potential scenarios that would be permissible based on the parking standards for the existing retail use. Alternative one was the combination of retail and residential land uses and alternative two was a combination of office and residential land uses. The study demonstrated that the nine proposed parking spaces would be adequate under alternative one, which required nine spaces, but one parking space short under alternative two, which required ten spaces.

A new office use in the commercial space at 1360 41st Avenue would not require any planning permits from the City of Capitola, so in order to ensure adequate parking for a potential office/residential use combination in the future, the Planning Commission could include the following condition in the conditions of approval:

Prior to an office use occupying the commercial portion of the structure, the property owner shall pay for a parking study to determine whether an excess parking space is available on an adjacent parcel that could provide one additional parking space for the office/residential mixed-use development on the subject parcel. If an excess parking space is available, the applicant shall enter into a long-term lease (for the life of the office/residential mixed-use residential development) for one additional parking space on the adjacent parcel.

CEQA

This project is categorically exempt under Section 15332 of the California Environmental Quality Act and is not subject to Section 753.5 of Title 14 of the California Code of Regulations. The proposed project involves the conversion of existing second-story commercial space into two new residential units within a commercial zone. No adverse environmental impacts were discovered during project review by Planning Department Staff.

RECOMMENDATION

Staff recommends the Planning Commission consider application #20-0359 and **approve** the application as proposed based on the following Conditions and Findings for Approval.

CONDITIONS OF APPROVAL

1. The project approval consists of two new residential units within an existing commercial structure. The maximum Floor Area Ratio for the 9,510 square foot property is 1.0 (9,510 square feet). The total FAR of the project is 0.479 with a total of 4,564 square feet, compliant with the maximum FAR within the zone. The proposed project is approved as indicated on the final plans reviewed and approved by the Planning Commission on November 5, 2020, except as modified through conditions imposed by the Planning Commission during the hearing.
2. Prior to construction, a building permit shall be secured for any new construction or modifications to structures authorized by this permit. Final building plans shall be consistent with the plans approved by the Planning Commission. All construction and site improvements shall be completed according to the approved plans
3. At time of submittal for building permit review, the Conditions of Approval must be printed in full on the cover sheet of the construction plans.
4. At time of submittal for building permit review, Public Works Standard Detail SMP STRM shall be printed in full and incorporated as a sheet into the construction plans. All construction shall be done in accordance with the Public Works Standard Detail BMP STRM.
5. Prior to making any changes to approved plans, modifications must be specifically requested and submitted in writing to the Community Development Department. Any significant changes to the size or exterior appearance of the structure shall require Planning Commission approval.
6. Prior to issuance of building permit, all Planning fees associated with permit #20-0359 shall be paid in full.
7. Prior to issuance of building permit, the developer shall pay Affordable housing in-lieu fees as required to assure compliance with the City of Capitola Affordable (Inclusionary) Housing Ordinance.

8. Prior to issuance of a building permit, the applicant must provide documentation of plan approval by the following entities: Santa Cruz County Sanitation Department, Soquel Creek Water District, and Central Fire Protection District.
9. Prior to issuance of building permits, a drainage plan, grading, sediment and erosion control plan, shall be submitted to the City and approved by Public Works. The plans shall be in compliance with the requirements specified in Capitola Municipal Code Chapter 13.16 Storm Water Pollution Prevention and Protection.
10. Prior to issuance of building permits, the applicant shall submit a stormwater management plan to the satisfaction of the Director of Public Works which implements all applicable Post Construction Requirements (PCRs) and Public Works Standard Details, including all standards relating to low impact development (LID).
11. Prior to any land disturbance, a pre-site inspection must be conducted by the grading official to verify compliance with the approved erosion and sediment control plan.
12. Prior to any work in the City road right of way, an encroachment permit shall be acquired by the contractor performing the work. No material or equipment storage may be placed in the road right-of-way.
13. During construction, any construction activity shall be subject to a construction noise curfew, except when otherwise specified in the building permit issued by the City. Construction noise shall be prohibited between the hours of nine p.m. and seven-thirty a.m. on weekdays. Construction noise shall be prohibited on weekends with the exception of Saturday work between nine a.m. and four p.m. or emergency work approved by the building official. §9.12.010B
14. Prior to a project final, all cracked or broken driveway approaches, curb, gutter, or sidewalk shall be replaced per the Public Works Standard Details and to the satisfaction of the Public Works Department. All replaced driveway approaches, curb, gutter or sidewalk shall meet current Accessibility Standards.
15. Prior to issuance of a Certificate of Occupancy, compliance with all conditions of approval shall be demonstrated to the satisfaction of the Community Development Director. Upon evidence of non-compliance with conditions of approval or applicable municipal code provisions, the applicant shall remedy the non-compliance to the satisfaction of the Community Development Director or shall file an application for a permit amendment for Planning Commission consideration. Failure to remedy a non-compliance in a timely manner may result in permit revocation.
16. This permit shall expire 24 months from the date of issuance. The applicant shall have an approved building permit and construction underway before this date to prevent permit expiration. Applications for extension may be submitted by the applicant prior to expiration pursuant to Municipal Code section 17.81.160 (Coastal).
17. The planning and infrastructure review and approval are transferable with the title to the underlying property so that an approved project may be conveyed or assigned by the applicant to others without losing the approval. The permit cannot be transferred off the site on which the approval was granted.

18. Upon receipt of certificate of occupancy, garbage and recycling containers shall be placed out of public view on non-collection days.

DESIGN PERMIT FINDINGS

A. The project, subject to the conditions imposed, secures the purposes of the Zoning Ordinance, General Plan, and Local Coastal Plan.

Community Development Staff, the Architectural and Site Review Committee, and the Planning Commission have all reviewed the project. The proposed two new residential units within an existing commercial structure comply with the development standards of the C-C (Community Commercial) Zoning District. The project secures the purpose of the Zoning Ordinance, General Plan, and Local Coastal Plan.

B. The project will maintain the character and integrity of the neighborhood.

Community Development Staff, the Architectural and Site Review Committee, and the Planning Commission have all reviewed the application for the two new residential units within an existing commercial structure. The design of the new residential units will fit in nicely with the existing neighborhood. The project will maintain the character and integrity of the neighborhood.

CALIFORNIA ENVIRONMENTAL QUALITY ACT (CEQA) FINDINGS

A. This project is categorically exempt under Section 15332 of the California Environmental Quality Act and is subject to Section 753.5 of Title 14 of the California Code of Regulations.

Section 15332 of the CEQA Guidelines exempts projects characterized as in-fill development when: the project is consistent with the applicable general plan designation and all applicable general plan policies as well as with applicable zoning designation and regulations; the proposed development occurs within city limits on a project site of no more than five acres substantially surrounded by urban uses; the project site has no value as habitat for endangered, rare, or threatened species; the project would not result in any significant effects relating to traffic, noise, air quality, or water quality; and the site can be adequately served by all required utilities and public services. This project involves the conversion of existing commercial space into two new residential units within the C-C (Community Commercial) zoning district. The proposed project is consistent with the in-fill development exemption and no adverse environmental impacts were discovered by Planning Staff during review of the proposed project.

ATTACHMENTS:

1. 1360 41st Avenue - Full Plan Set - 10.29.2020
2. 1360 41st Avenue - Parking Study - 09.15.2020

Prepared By: Matt Orbach
Associate Planner

TWO APARTMENT CONVERSION FOR THE ALLEN PROPERTY GROUP

1360 41st AVENUE, CAPITOLA, CALIFORNIA

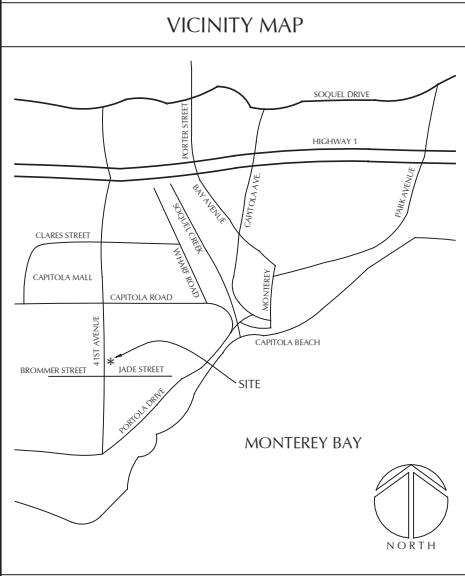

PROJECT DATA

OWNER:	ALLEN PROPERTY GROUP, INC. 347 SPRECKLES DRIVE APTOS, CALIFORNIA 95003 831 688-5100
PROJECT SITE:	1360 41st AVENUE CAPITOLA, CALIFORNIA
ASSESSORS PARCEL NUMBER:	034-101-16
LOT AREA:	9,510 S.F.
FLOOR AREA CALCULATION:	FIRST FLOOR: 3,665 S.F. SECOND FLOOR: 1,629 S.F. TOTAL: 4,564 S.F.
FIRST FLOOR BREAKDOWN:	HEATED AREA: 2,887 S.F. GARAGE AREA: 778 S.F.
OCCUPANCY TYPE:	GROUP B, R-3
CONSTRUCTION TYPE:	TYPE V-N
SPRINKLERS:	NONE EXISTING
PROJECT DESCRIPTION:	TENANT IMPROVEMENT OF EXISTING BUILDING TO ADD TWO NEW APARTMENTS IN THE EXISTING SECOND FLOOR SPACE

FIRE PROTECTION NOTES

GENERAL NOTES

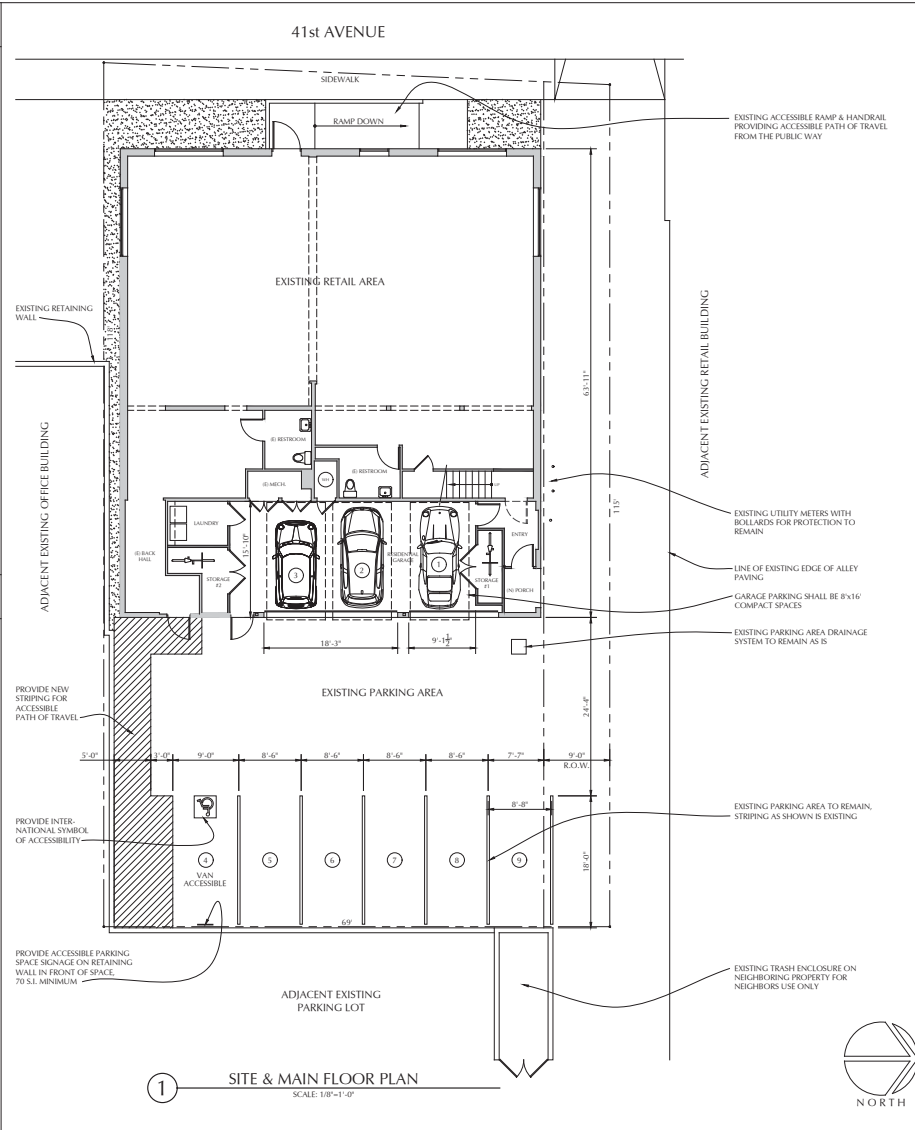

Attachment: 1360 41st Avenue - Full Plan Set - 10.29.2020 (1360 41st Avenue)



WILLIAM C. KEMPf
ARCHITECTS
911 Center Street, Suite F
Santa Cruz, CA 95060
831.459.0951
www.wckempf.com

TWO APARTMENT CONVERSION FOR
THE ALLEN PROPERTY GROUP
1360 41ST AVENUE, CAPITOLA, CALIFORNIA
SITE & MAIN FLOOR PLAN, VICINITY MAP

SAWING DATE: AUGUST 27, 2020
P.N.: 034-101-16
JOB NAME: ALLEN PROP. GROUP, INC.
PROJECT NAME: 1360 41ST AVENUE

REVISIONS	DESCRIPTION	DATE
1	PLANNING	10/6/20
2	PLANNING	10/29/20

DISCLAIMER
THE DATA SET FORTH ON THIS SHEET IS THE PROPERTY OF WILLIAM C. KEMPf ARCHITECTS. IT IS AN INSTRUMENT OF SERVICE AND MAY NOT BE REPRODUCED, COPIED, OR TRANSMITTED IN ANY FORM OR BY ANY MEANS, ELECTRONIC OR MECHANICAL, INCLUDING PHOTOCOPYING, RECORDING, OR BY ANY INFORMATION STORAGE AND RETRIEVAL SYSTEM, WITHOUT THE WRITTEN PERMISSION OF WILLIAM C. KEMPf ARCHITECTS.



A1.1



WILLIAM C. KEMPFF
ARCHITECTS
911 Center Street, Suite F
Santa Cruz, CA 95060
831.459.0951
www.wckempff.com

Attachment: 1360 41st Avenue - Full Plan Set - 10.29.2020 (1360 41st Avenue)

TWO APARTMENT CONVERSION FOR
THE ALLEN PROPERTY GROUP
1360 41ST AVENUE, CAPITOLA, CALIFORNIA
EXISTING FLOOR PLANS

ISSUING DATE: AUGUST 27, 2020
P.N.: 034-101-16
CLIENT NAME: ALLEN PROP. GROUP, INC.
PROJECT NAME: 1360 41ST AVENUE

REVISIONS	
DESCRIPTION	DATE
PLANNING	10/6/20

DISCLAIMER
THE DATA SET FORTH ON THIS SHEET IS THE PROPERTY OF WILLIAM C. KEMPFF ARCHITECTS. IT IS AN INSTRUMENT OF SERVICE AND MAY NOT BE REPRODUCED, COPIED, OR TRANSMITTED IN ANY FORM OR BY ANY MEANS, ELECTRONIC OR MECHANICAL, WITHOUT THE WRITTEN PERMISSION OF WILLIAM C. KEMPFF ARCHITECTS. THE PROJECT IS THE PROPERTY OF WILLIAM C. KEMPFF ARCHITECTS. UNAUTHORIZED USE IS PROHIBITED.

A2.1

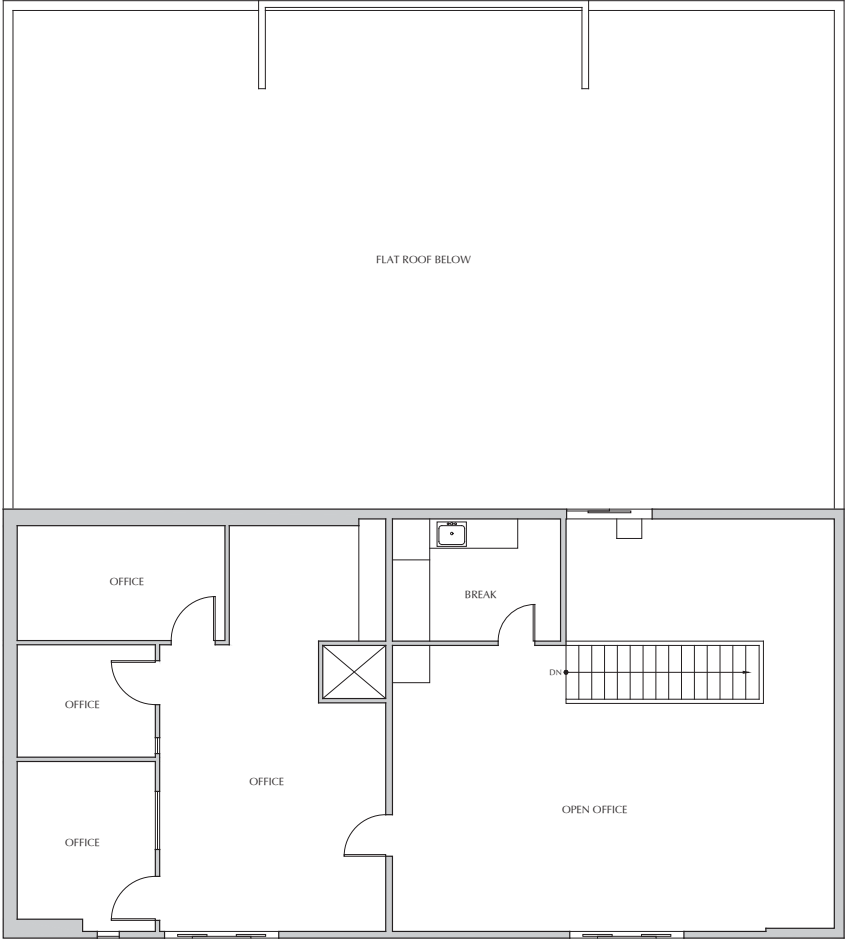

NO WORK PROPOSED FOR EXISTING SECOND FLOOR

2 EXISTING SECOND FLOOR PLAN

SCALE: 1/4"=1'-0"

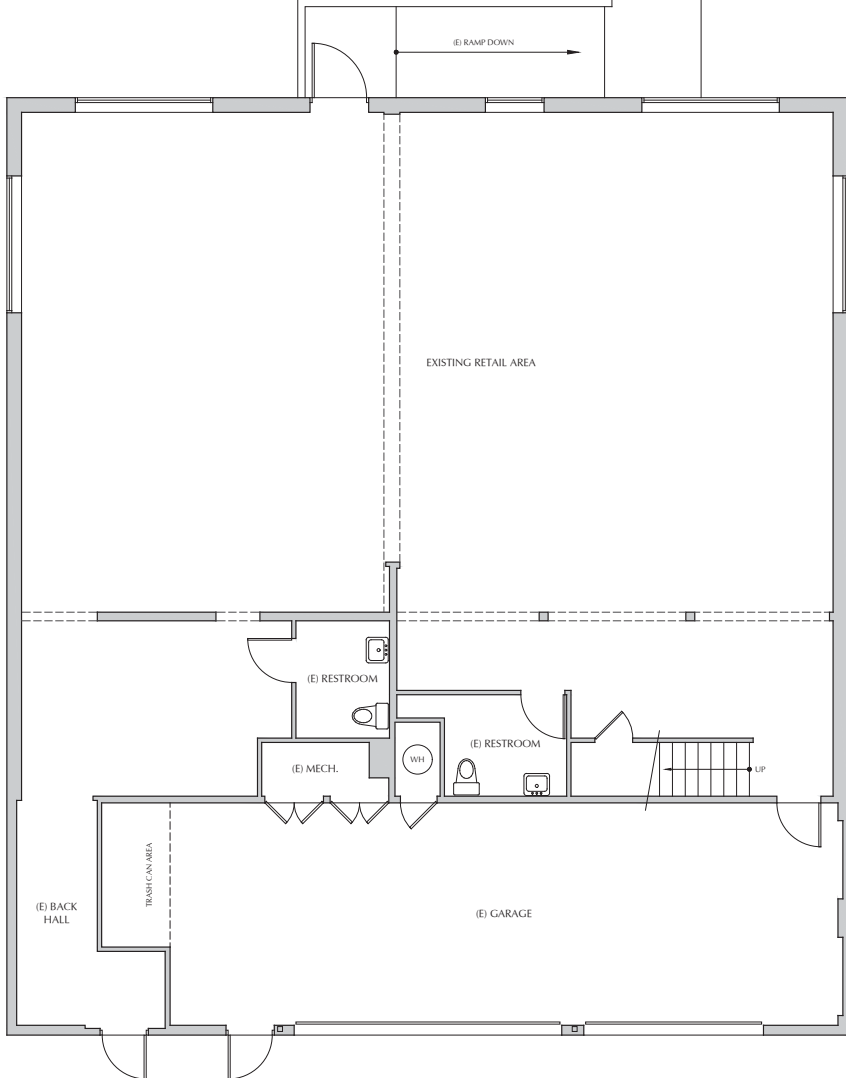

1 EXISTING FIRST FLOOR PLAN

SCALE: 1/4"=1'-0"





WILLIAM C. KEMPf
ARCHITECTS
911 Center Street, Suite F
Santa Cruz, CA 95060
831.459.0951
www.wckempf.com

Attachment: 1360 41st Avenue - Full Plan Set - 10.29.2020 (1360 41st Avenue)

TWO APARTMENT CONVERSION FOR
THE ALLEN PROPERTY GROUP
1360 41ST AVENUE, CAPITOLA, CALIFORNIA
PROPOSED FLOOR PLANS

ISSUING DATE:
AUGUST 27, 2020
P.N.:
034-101-16
CLIENT NAME:
ALLEN PROP. GROUP, INC.
PROJECT NAME:
1360 41ST AVENUE

REVISIONS	
DESCRIPTION	DATE
PLANNING	10/6/20
PLANNING	10/29/20

DISCLAIMER
THE DATA SET FOR THIS PLAN SHEET IS THE PROPERTY OF WILLIAM C. KEMPf ARCHITECTS. IT IS AN INSTRUMENT OF SERVICE AND MAY NOT BE REPRODUCED, COPIED, OR TRANSMITTED IN ANY FORM OR BY ANY MEANS WITHOUT THE WRITTEN PERMISSION OF WILLIAM C. KEMPf ARCHITECTS. THE ARCHITECT ASSUMES NO LIABILITY TO THE ARCHITECT OR CLIENT FOR ANY DAMAGE TO PERSONS OR PROPERTY CAUSED BY THE USE OF THIS INSTRUMENT OF SERVICE.

A2.2

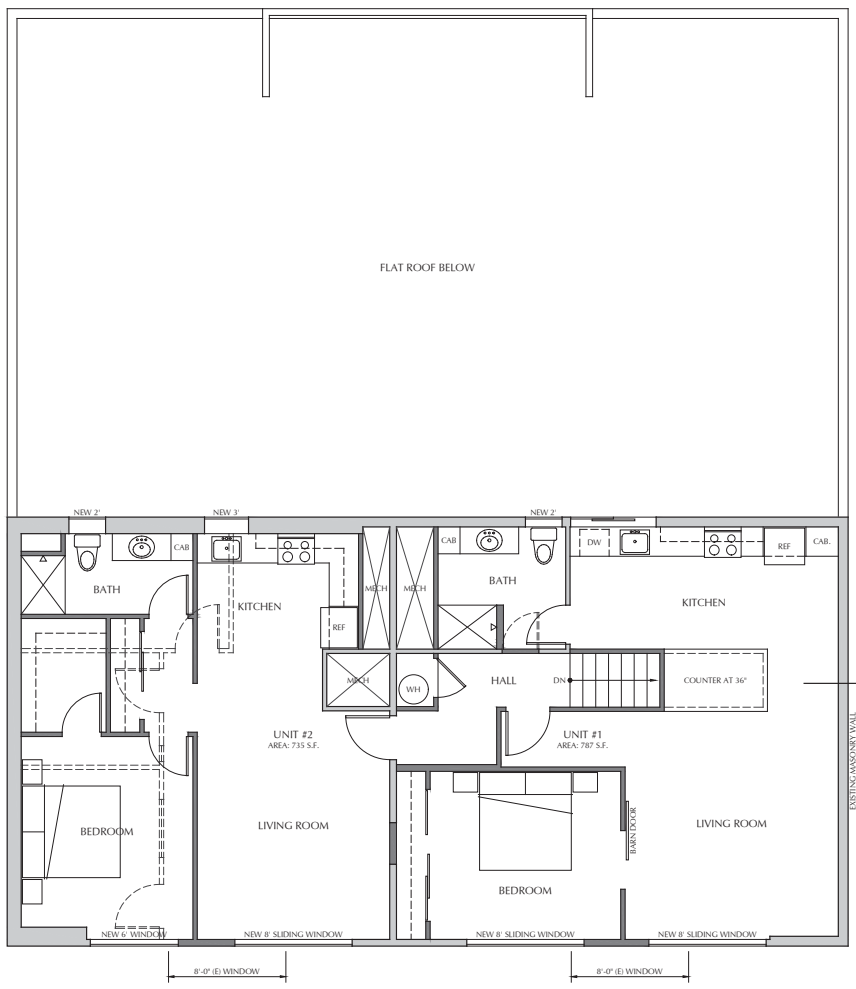

2 PROPOSED SECOND FLOOR PLAN
SCALE: 1/4"=1'-0"

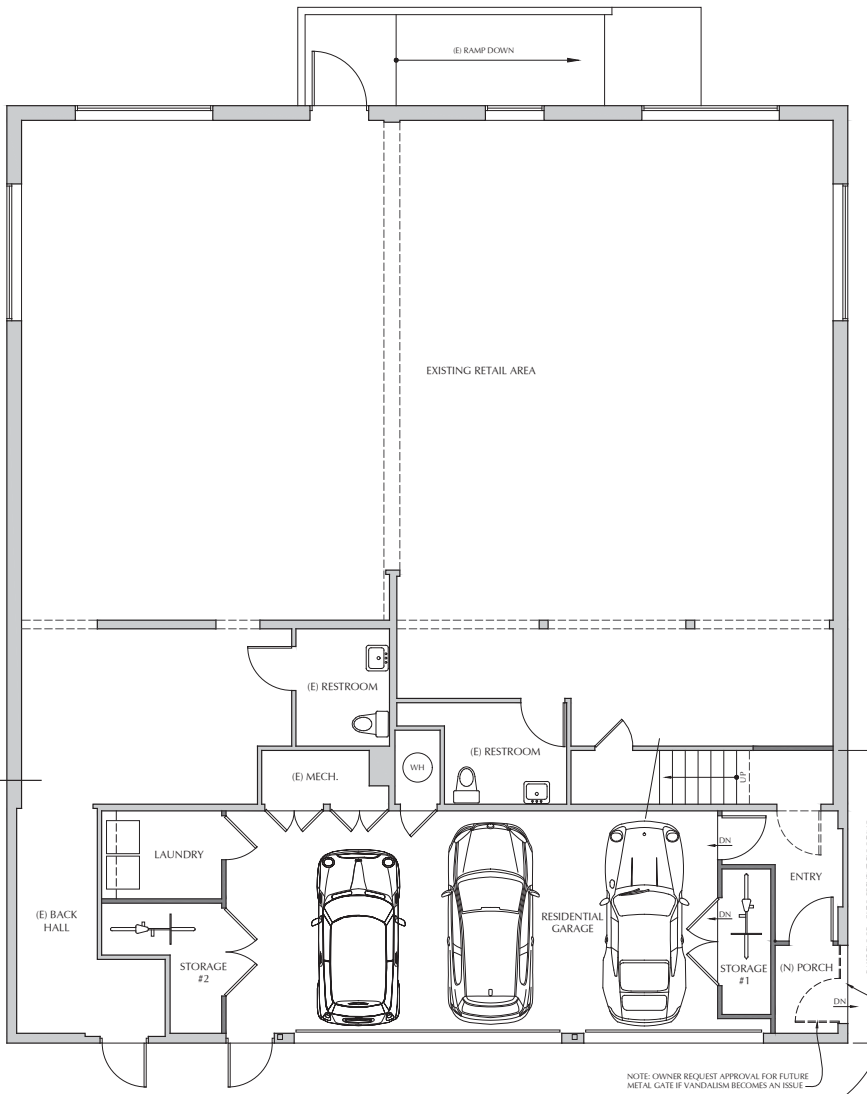

1 PROPOSED FIRST FLOOR PLAN
SCALE: 1/4"=1'-0"



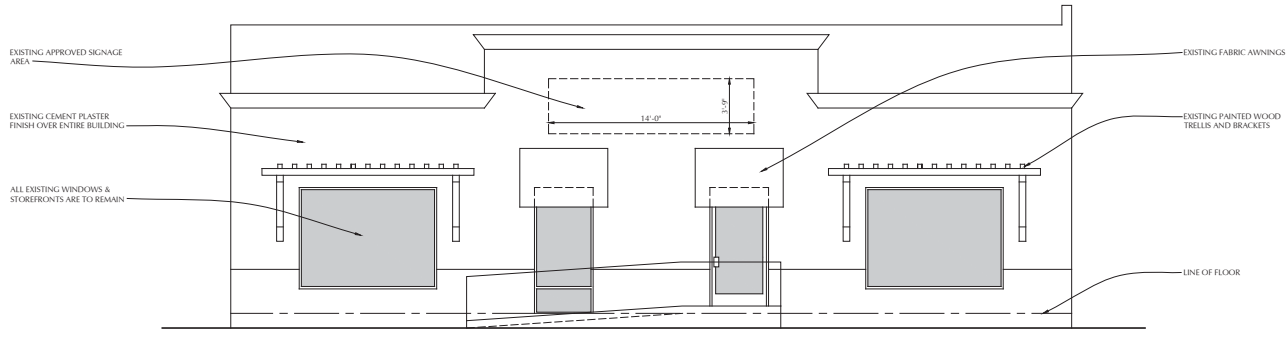

1 PROPOSED WEST ELEVATION
SCALE: 1/4"=1'-0"

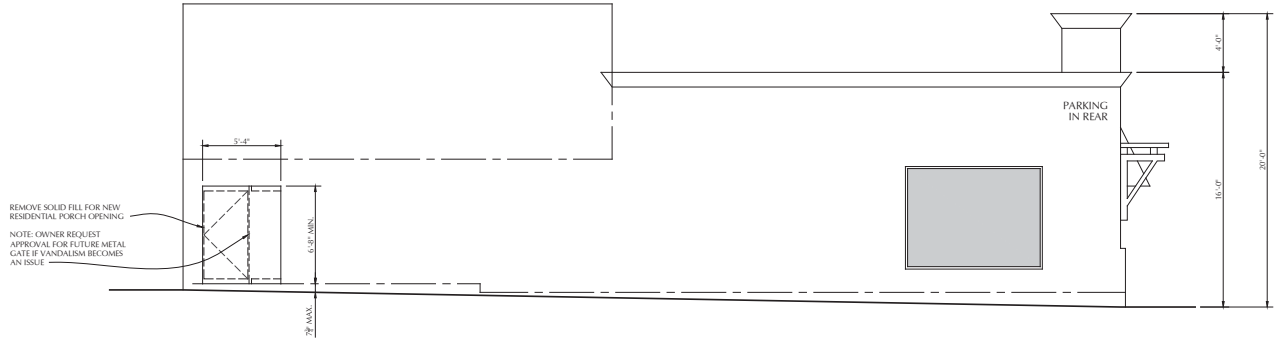

2 PROPOSED NORTH ELEVATION
SCALE: 1/4"=1'-0"

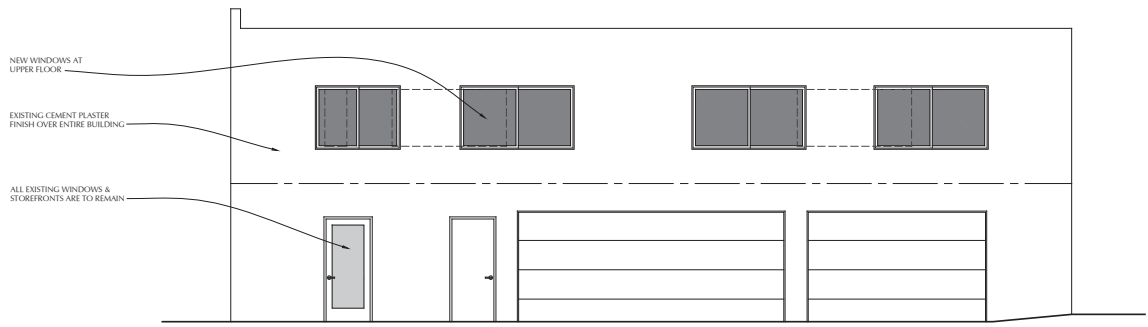

3 PROPOSED EAST ELEVATION
SCALE: 1/4"=1'-0"



WILLIAM C. KEMPf
ARCHITECTS
911 Center Street, Suite F
Santa Cruz, CA 95060
831.459.0951
www.wckempf.com

Attachment: 1360 41st Avenue - Full Plan Set - 10.29.2020 (1360 41st Avenue)

TWO APARTMENT CONVERSION FOR
THE ALLEN PROPERTY GROUP
1360 41ST AVENUE, CAPITOLA, CALIFORNIA
PROPOSED EXTERIOR ELEVATIONS

ISSUING DATE: AUGUST 27, 2020
P.N.: 034-101-16
JOB NAME: ALLEN PROP. GROUP, INC.
PROJECT NAME: 1360 41ST AVENUE

REVISIONS		
DESCRIPTION	DATE	
PLANNING	10/6/20	

DISCLAIMER
THE DATA SET FOR THIS SHEET IS THE PROPERTY OF WILLIAM C. KEMPf ARCHITECTS. IT IS AN INSTRUMENT OF SERVICE AND MAY NOT BE REPRODUCED, COPIED, OR TRANSMITTED IN ANY FORM OR BY ANY MEANS, ELECTRONIC OR MECHANICAL, INCLUDING PHOTOCOPYING, RECORDING, OR BY ANY INFORMATION STORAGE AND RETRIEVAL SYSTEM, WITHOUT THE WRITTEN PERMISSION OF WILLIAM C. KEMPf ARCHITECTS.

A3.1

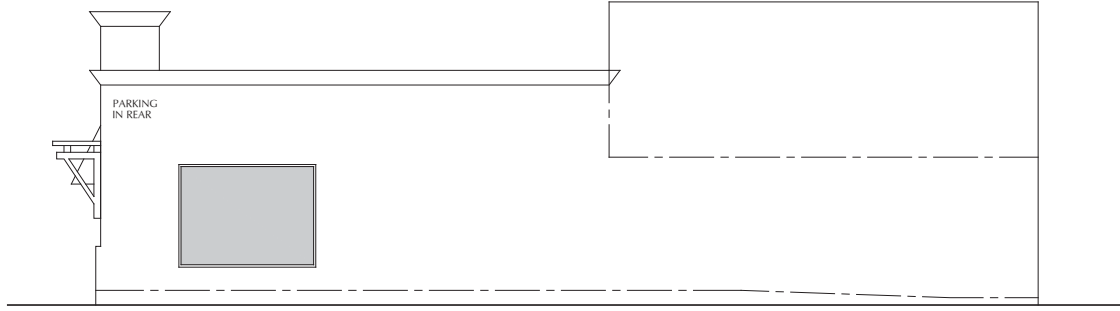

① EXISTING SOUTH ELEVATION
SCALE: 1/4"=1'-0"

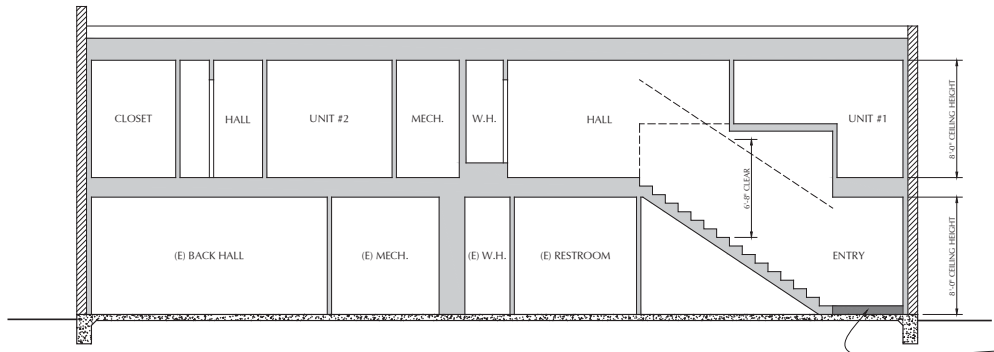

② PROPOSED ARCHITECTURAL SECTION
SCALE: 1/4"=1'-0"



WILLIAM C. KEMPF ARCHITECTS
911 Center Street, Suite F
Santa Cruz, CA 95060
831.459.0951
www.wckempf.com

Attachment: 1360 41st Avenue - Full Plan Set - 10.29.2020 (1360 41st Avenue)

TWO APARTMENT CONVERSION FOR
THE ALLEN PROPERTY GROUP
1360 41ST AVENUE, CAPITOLA, CALIFORNIA
SOUTH ELEV. & ARCHITECTURAL SECTION

SAWING DATE: AUGUST 27, 2020
P.N.: 034-101-16
AGENT NAME: ALLEN PROP. GROUP, INC.
PROJECT NAME: 1360 41ST AVENUE

REVISIONS		
DESCRIPTION	DATE	
PLANNING	10/6/20	

DISCLAIMER
THE DATA SET FOR THIS PLAN SET IS THE PROPERTY OF WILLIAM C. KEMPF ARCHITECTS. IT IS AN INSTRUMENT OF SERVICE AND MAY NOT BE REPRODUCED, COPIED, OR TRANSMITTED IN ANY FORM OR BY ANY MEANS, WITHOUT THE WRITTEN PERMISSION OF THE ARCHITECTS. THE ARCHITECTS ASSUME NO LIABILITY FOR ANY ERRORS OR OMISSIONS IN THIS DOCUMENT. THE ARCHITECTS SHALL BE RESPONSIBLE FOR THE ACCURACY OF THE INFORMATION PROVIDED TO THE ARCHITECTS. CONSULT WITH THE ARCHITECTS FOR ANY QUESTIONS OR CONCERNS.

A3.2

TECHNICAL MEMORANDUM

To: Matt Orbach, City of Capitola Assistant Planner
From: Frederik Venter P.E., Derek Wu P.E., & Jake Mirabella, Kimley-Horn and Associates, Inc.
Date: September 15, 2020
Re: 1360 41st Avenue – Site Redevelopment Trip & Parking Study

This technical memorandum provides a trip generation and parking analysis for the proposed 1360 41st Avenue redevelopment in Capitola, California located within the Coastal Zone C-C (Community Commercial) zoning district. The Project proposes to redevelop the existing building to approximately 2,887 square-feet of retail or office (first floor) and two one-bedroom apartments (second floor). The existing driveways, parking lot layout, and parking garage on the Project site will not be changed as part of this redevelopment. A site plan of the proposed Project is shown in the **Appendix**.

1. Project Trip Generation

Trip generation for the proposed Project was calculated using trip generation rates from the Institute of Transportation Engineers (ITE) *Trip Generation Manual, 10th Edition*. Weekday daily, AM, and PM peak hour trips for the Project was calculated using average trip rates.

Existing Trip Generation Assumptions

ITE’s Shopping Center (land use 820) trip rate was assumed for the 4,516 square-feet of retail use (2,887 SQFT first floor + 1,629 SQFT second floor). It should be noted that the shopping center land use serves as a conservative estimate compared to the project characteristics and expected tenant use.

Project Trip Generation Assumptions

ITE’s Shopping Center (land use 820) trip rate was assumed for the first floor 2,887 square-feet of retail use. It should be noted that the shopping center land use serves as a conservative estimate compared to the project characteristics and expected tenant use.

ITE’s Small Office Building (land use 712) was also assumed as a potential first floor office use alternative to retail. The Low-Rise Multifamily Housing (land use 220) was assumed for the second-floor apartment units.

Trip Generation Summary

As shown in **Table 1** below, the Project would generate approximately 124 gross daily trips, 4 gross AM peak hour trips, and 12 gross PM peak hour trips with retail and apartment uses (Alternative 1). The Project would generate 62 gross daily trips, 7 gross AM peak hour trips, and 8 gross PM peak hour trips with office and apartment uses (Alternative 2).

Assuming 170 gross daily trips, 4 gross AM peak hour trips, and 17 gross PM peak hour trips as existing trip credits, the Project would generate a net decrease of 46 fewer net daily trips, 0 net AM peak hour trips, and 5 fewer net PM peak hour trips with Alternative 1. Alternative 2 would have a net decrease of 108 fewer net new daily trips, 3 net new AM peak hour trips, and 9 fewer net PM peak hour trips.

Internal capture and pass-by trip reductions are conservatively not assumed in this analysis.

Attachment: 1360 41st Avenue - Parking Study - 09.15.2020 (1360 41st Avenue)

Table 1: ITE Project Trip Generation Alternatives (1360 41st Avenue)

LAND USE / DESCRIPTION	PROJECT SIZE		TOTAL DAILY TRIPS	AM PEAK TRIPS			PM PEAK TRIPS				
				TOTAL	IN	OUT	TOTAL	IN	OUT		
Trip Generation Rates (ITE)											
Multifamily Housing (Low-Rise)	Per	Dwelling Unit(s)	7.32	0.46	23%	/	77%	0.56	63%	/	37%
Small Office Building	Per	1,000 Sq Ft	16.19	1.92	83%	/	17%	2.45	32%	/	68%
Shopping Center	Per	1,000 Sq Ft GLA	37.75	0.94	62%	/	38%	3.81	48%	/	52%
Existing Conditions											
Retail Store (1st & 2nd Floor)	4.52	1,000 Sq Ft GLA	170	4	2	/	2	17	8	/	9
Total Existing Vehicle-Trips			170	4	2	/	2	17	8	/	9
Proposed Conditions (Alternative 1)											
Multifamily (2nd Floor)	2.00	Dwelling Units(s)	15	1	0	/	1	1	1	/	0
Retail Store (1st Floor)	2.88	1,000 Sq Ft GLA	109	3	2	/	1	11	5	/	6
Total Gross Vehicle-Trips (Alternative 1)			124	4	2	/	2	12	6	/	6
Proposed Conditions (Alternative 2)											
Multifamily (2nd Floor)	2.00	Dwelling Units(s)	15	1	0	/	1	1	1	/	0
Office Space (1st Floor)	2.88	1,000 Sq Ft	47	6	5	/	1	7	2	/	5
Total Gross Vehicle-Trips (Alternative 2)			62	7	5	/	2	8	3	/	5
Net Project Vehicle-Trips (Alternative 1)			(46)	0	0	/	0	(5)	(2)	/	(3)
Net Project Vehicle-Trips (Alternative 2)			(108)	3	3	/	0	(9)	(5)	/	(4)
Notes:											
Land Uses assumed based on proposed site plan from Alan Property Group (8/27/2020)											
Daily, AM, and PM trips based on average land use rates from the Institute of Traffic Engineers Trip Generation											

2. Project Parking Generation

Parking generation for the proposed project was calculated using vehicle parking generation rates from the Institute of Transportation Engineers (ITE) *Parking Generation Manual, 5th Edition*. Average, 33% and 85% parking demand for the Project during the weekday and weekend was calculated with average rates for retail and apartment (Alternative 1) and office and apartment (Alternative 2) Project alternatives.

ITE’s Shopping Center (land use 820) trip rate was assumed for the first floor 2,887 square-feet of retail use. ITE’s Office Building (land use 701) was assumed as a potential first floor office use alternative to retail. Low/Midrise Apartment (land use 221) was assumed for the second-floor apartment units.

A summary of the project parking generation is shown in **Table 2**. The project with apartment and retail uses (Alternative 1) would generate an average peak parking demand of 9 vehicle spaces. The project with apartment and office uses (Alternative 2) would generate an average peak parking demand of 10 vehicle spaces.

Attachment: 1360 41st Avenue - Parking Study - 09.15.2020 (1360 41st Avenue)

Table 2: ITE Project Parking Generation (1360 41st Avenue)

LAND USE / DESCRIPTION	PROJECT SIZE	PEAK DEMAND		
		AVG	33%	85%
Parking Generation Rates (ITE 5th Edition)				
Low/Midrise Apartment (Suburban) [221]	Per DU	1.23	0.68	1.94
Office Building (Suburban) [701]	Per KSF	2.84	2.56	3.45
Shopping Center [820]	Per KSF	2.55	2.20	3.16
Existing Conditions (1360 41st Avenue)				
Retail Store (1st & 2nd Floor)	4.52 KSF	12	10	14
Total Parking Demand (Existing)		12	10	14
Proposed Conditions (Alternative 1)				
Multifamily (2nd Floor)	2.00 DU	2	1	4
Retail Store (1st Floor)	2.88 KSF	7	6	9
Total Parking Demand (Alternative 1)		9	7	13
Proposed Conditions (Alternative 2)				
Multifamily (2nd Floor)	2.00 DU	2	1	4
Office Space(1st Floor)	2.88 KSF	8	7	10
Total Parking Demand (Alternative 2)		10	8	14
Notes:				
Average, 33%, and 85% peak parking demand based on land use rates from the Institute of Traffic Engineers Parking Generation 5th Edition				

3. Project Parking Analysis

The project site plan is proposing to provide up to nine (9) vehicle parking spaces and two (2) long-term bicycle parking spaces. Three (3) parking spaces are located in the 1st floor garage for residential use and six (6) parking spaces are striped in the parking lot behind the building for multi-purpose use. One (1) van ADA parking space is provided.

The project is in the coastal zoning area and subject to conditions in City of Capitola Municipal Code Title 17 Zoning – Coastal Areas Section 17.27.120 and Section 17.51.130. For purposes of this analysis, commercial retail and office use requires one (1) vehicle parking space per 300 square-feet of enclosed gross floor area while apartment duplex or triplex units require two (2) vehicle parking space per dwelling unit.

Based on City coastal zoning parking code, the project would be required to provide a minimum of 14 vehicle spaces. The proposed parking supply of 9 vehicle spaces would not satisfy the applicable City coastal zoning parking standards as shown in **Table 3**. The project would have a parking shortfall of 5 spaces.

Attachment: 1360 41st Avenue - Parking Study - 09.15.2020 (1360 41st Avenue)

Table 3: Project Required Parking Summary (1360 41st Avenue)

CODE / STANDARD	SCENARIO	LAND USE	PARKING STANDARD	REQUIRED PARKING SPACES		PROPOSED PARKING SUPPLY	SUFFICIENT PARKING?
ITE Parking Demand	Existing Conditions	Retail Only	See Table 2 for ITE parking rates	12		9	No
	Alt 1	Retail and Residential	See Table 2 for ITE parking rates	9		9	Yes
	Alt 2	Office and Residential	See Table 2 for ITE parking rates	10		9	No
Capitola Coastal Areas Section 17.27.120	Existing Conditions	Commercial - Retail and Office	1 space per 300 square feet of floor space	15		9	No
	Alt 1 & Alt 2	Residential - Duplex or Triplex	2 spaces per unit (1 space must be covered)	4	14	9	No
		Commercial - Retail and Office	1 space per 300 square feet of floor space	10			

4. Shared Parking Analysis

A shared parking lot at 1408 41st Avenue with 15 existing parking spaces is located next to the project site. Improvements to this adjacent shared parking lot will provide 9 additional vehicle parking spaces creating a total parking supply of 24 spaces as shown in the **Appendix**. This shared parking lot accommodates employee and visitor parking for retail and residential uses in the 1408 41st Avenue property. The estimated ITE parking demand and the required on-site parking for these uses per City Municipal Code are summarized in **Table 4 & Table 5** below.

Table 4: ITE Shared Parking Generation (1408 41st Avenue)

LAND USE / DESCRIPTION	PROJECT SIZE	PEAK DEMAND		
		AVG	33%	85%
Parking Generation Rates (ITE 5th Edition)				
Single Family Detached Housing [210]	Per DU	1.83	1.67	2.14
Shopping Center [820]	Per KSF	2.55	2.20	3.16
Existing Conditions (Shared Lot)				
Retail Store (1408 41 st Avenue)	4.83 KSF	12	11	15
Single Family Home (1408 B 41 st Avenue)	1.00 DU	2	2	2
Total Parking Demand (Shared Lot)		14	13	17
Notes:				
Average, 33%, and 85% peak parking demand based on land use rates from the Institute of Traffic Engineers Parking Generation 5th Edition				

As shown in Table 4, the estimated average ITE parking demand for the 1408 41st Avenue shared parking lot is about 14 spaces. With a proposed parking supply of 24 spaces, the shared lot could potentially have up to 10 extra parking spaces per ITE methodology.

Attachment: 1360 41st Avenue - Parking Study - 09.15.2020 (1360 41st Avenue)

Table 5: Shared Lot Required Parking Summary (1408 41st Avenue)

CODE / STANDARD	ADDRESS	LAND USE	PARKING STANDARD	LAND USE SIZE	REQUIRED PARKING SPACES	PROPOSED PARKING SUPPLY	REMAINING PARKING SPACES
Capitola Coastal Areas Section 17.27.120 &	1408 41st Avenue	Commercial - Retail and Office	1 space per 300 square feet of floor space	4,828 SQFT	16	24	6
	1408 B 41st Avenue	Residential - Single Family	2 spaces per each unit less than 1,500 SQFT	957 SQFT	2		

As shown in Table 5, the required parking for the 1408 41st Avenue shared lot is approximately 18 spaces assuming the existing land uses remain per City Municipal Code. With the proposed improvements and a total parking supply of 24 spaces, the shared lot could potentially have up to 6 surplus parking spaces. If the project has shared parking rights at the lot, the surplus parking spaces could partially mitigate the project’s on-site parking shortfall.

5. Conclusion / Recommendations

The proposed multi-use development is expected to generate fewer net vehicle trips than the existing retail use that would be replaced, and the total net project trips do not exceed Caltrans trip generation thresholds for determining the need for a traffic impact study. The project is not anticipated to create a significant impact to traffic operations for the surrounding roadway network.

The project’s proposed on-site parking would satisfy ITE parking demand for retail and residential use (Alternative 1) but would have a parking shortfall of 5 spaces per City coastal zoning code. The shared parking lot at 1408 41st Avenue will also be improved and could have surplus parking that could partially mitigate project’s on-site parking shortfall.

5. Appendix

- 1360 41st Avenue site plan by Allen Property Group
- 1408 41st Avenue Parking Lot Improvements for Santa Cruz Beach LLC by Roper Engineering

Attachment: 1360 41st Avenue - Parking Study - 09.15.2020 (1360 41st Avenue)

TWO APARTMENT CONVERSION FOR THE ALLEN PROPERTY GROUP 1360 41st AVENUE, CAPITOLA, CALIFORNIA

VICINITY MAP

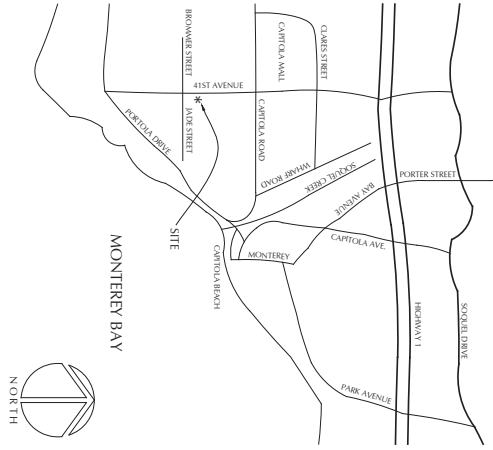

PROJECT DATA

OWNER: ALLEN PROPERTY GROUP, INC.
347 SHERCLES DRIVE
APTOS, CALIFORNIA 95003
831 688-5100

PROJECT SITE: 1360 41st AVENUE
CAPITOLA, CALIFORNIA

ASSESSORS PARCEL NUMBER: 034101-16

LOT AREA: 9,510 S.F.

FLOOR AREA CALCULATION:
FIRST FLOOR: 3,665 S.F.
SECOND FLOOR: 1,829 S.F.
TOTAL: 5,494 S.F.

FIRST FLOOR BREAKDOWN:
HEATED AREA: 2,887 S.F.
GARAGE AREA: 778 S.F.

OCCUPANCY TYPE: GROUP B, B-3

CONSTRUCTION TYPE: TYPE VAN

SPRINKLERS: NONE EXISTING

PROJECT DESCRIPTION:
TENANT IMPROVEMENT OF EXISTING BUILDING TO ADD TWO NEW APARTMENTS

FIRE PROTECTION NOTES

GENERAL NOTES

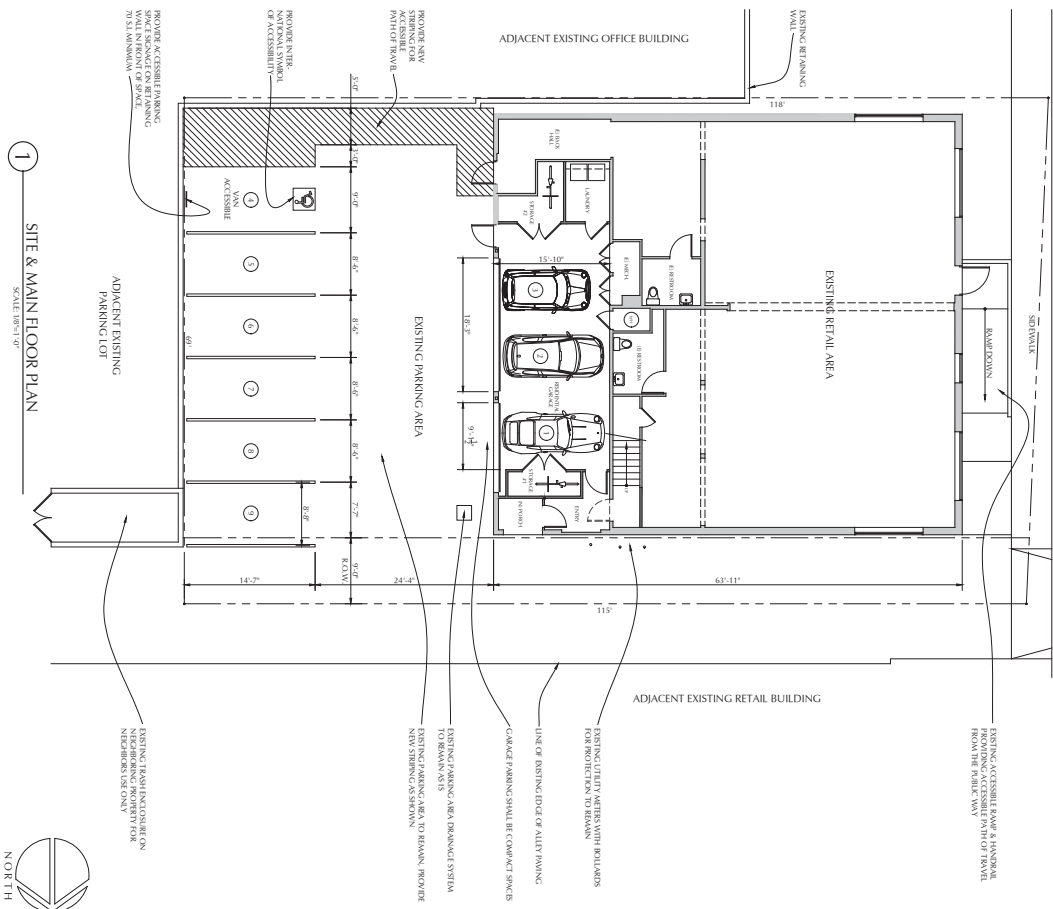

WILLIAMS_KEMP ARCHITECT
9111 Cedar Street, Suite F
Capitola, CA 95006
831.450.0551
www.williamskemp.com

TWO APARTMENT CONVERSION FOR
THE ALLEN PROPERTY GROUP
1360 41ST AVENUE, CAPITOLA, CALIFORNIA
SITE & MAIN FLOOR PLAN, VICINITY MAP

DRAWING DATE	AGENCY Z#	CLIENT NAME	PROJECT NAME
09.15.2020	2020	ALLEN PROPERTY GROUP, INC.	1360 41ST AVENUE

REVISIONS	DATE

DISCLAIMER

THIS DRAWING IS THE PROPERTY OF WILLIAMS_KEMP ARCHITECT. IT IS TO BE USED ONLY FOR THE PROJECT AND SITE SPECIFICALLY IDENTIFIED HEREIN. ANY REUSE OR MODIFICATION OF THIS DRAWING WITHOUT THE WRITTEN CONSENT OF WILLIAMS_KEMP ARCHITECT IS STRICTLY PROHIBITED.

A1.1

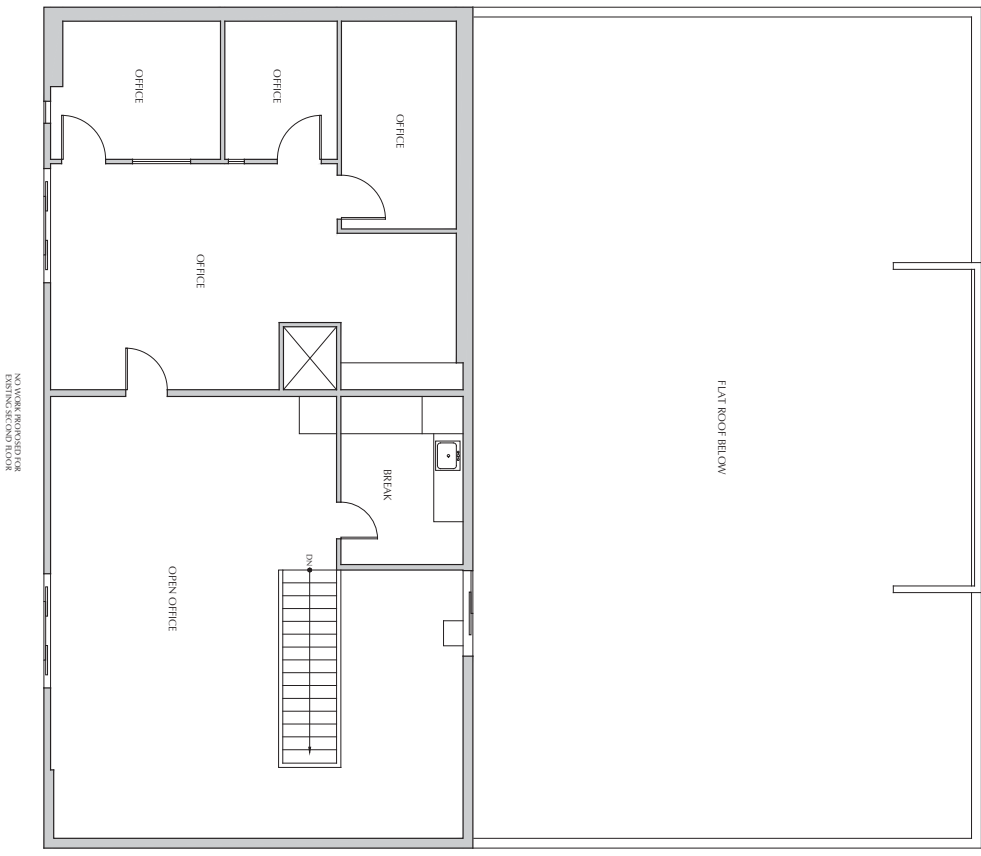

2 EXISTING SECOND FLOOR PLAN
SCALE 1/8"=1'-0"

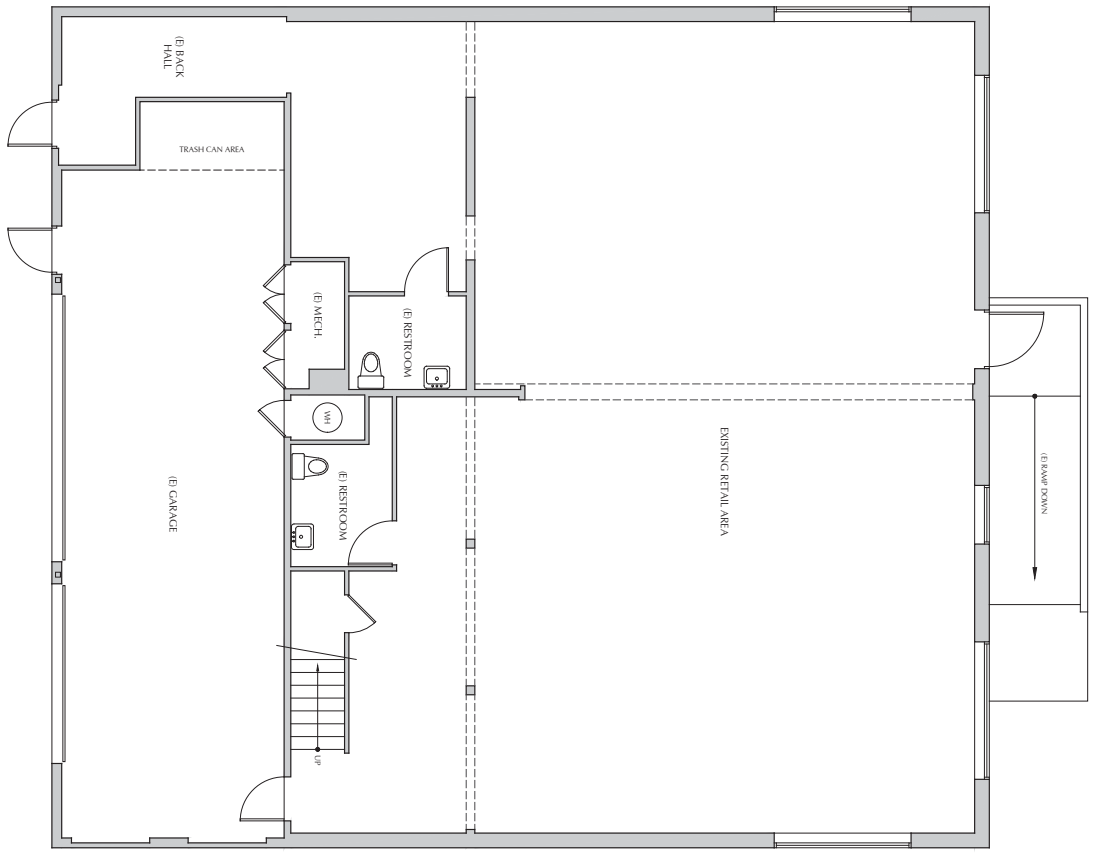

1 EXISTING FIRST FLOOR PLAN
SCALE 1/8"=1'-0"



A2.1

DATE	
NO.	

REVISIONS	
NO.	
DESCRIPTION	
DATE	

PROJECT NO.	
CLIENT NAME	
PROJECT NAME	
DATE	

DRAWING DATE	
ARCHIT. DATE	
CLIENT NAME	
PROJECT NAME	
DATE	

TWO APARTMENT CONVERSION FOR
THE ALLEN PROPERTY GROUP
 1360 41ST AVENUE, CAPITOLA, CALIFORNIA
 EXISTING FLOOR PLANS

WILLIAMS KEMP
 ARCHITECT
 5111 Cedar Street, Suite F
 San Francisco, CA 94124
 415.774.8551
 www.williamskemp.com

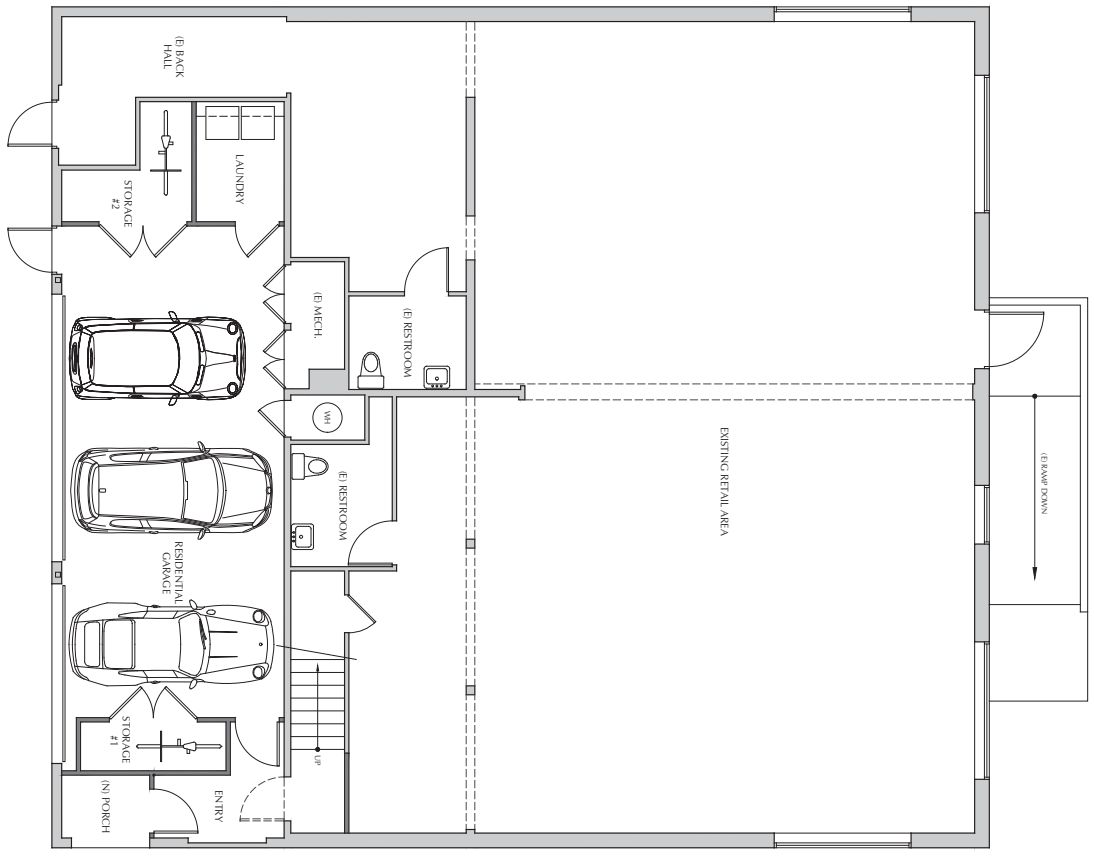
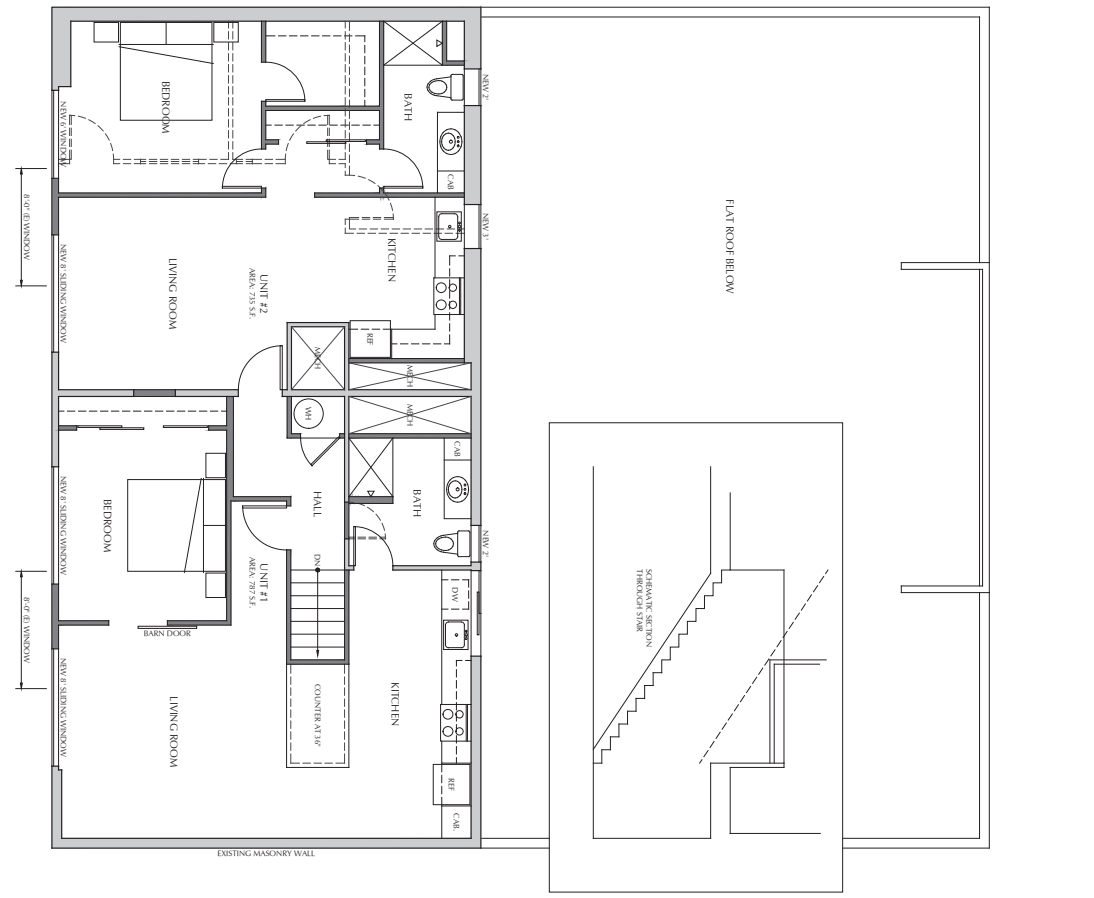

2 PROPOSED SECOND FLOOR PLAN
SCALE: 1/4" = 1'-0"

1 PROPOSED FIRST FLOOR PLAN
SCALE: 1/4" = 1'-0"



A2.2

DATE: 09/15/2020
DRAWING NO: A2.2

PROJECT: TWO APARTMENT CONVERSION FOR THE ALLEN PROPERTY GROUP
1360 41ST AVENUE, CAPITOLA, CALIFORNIA

CLIENT: ALLEN PROPERTY GROUP, INC.
PROJECT MANAGER: [Name]

DESIGNER: [Name]
DATE: 09/15/2020

TWO APARTMENT CONVERSION FOR
THE ALLEN PROPERTY GROUP
1360 41ST AVENUE, CAPITOLA, CALIFORNIA
PROPOSED FLOOR PLANS

WILLIAMS, KEMPF ARCHITECT
9111 Corner Street, Suite F
Capitola, CA 95010
408.434.0500
www.wkempff.com

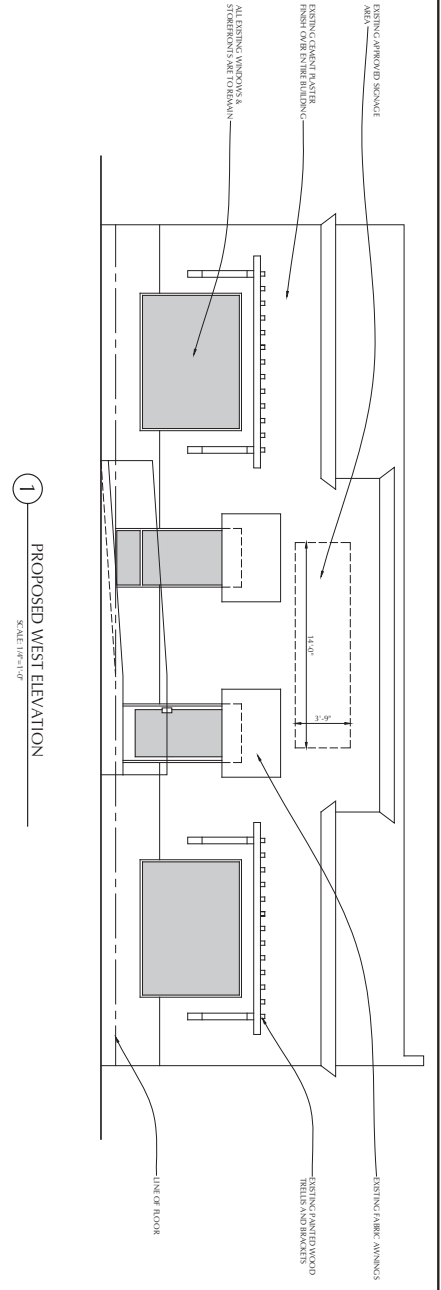

1 PROPOSED WEST ELEVATION
SCALE: 1/8"=1'-0"

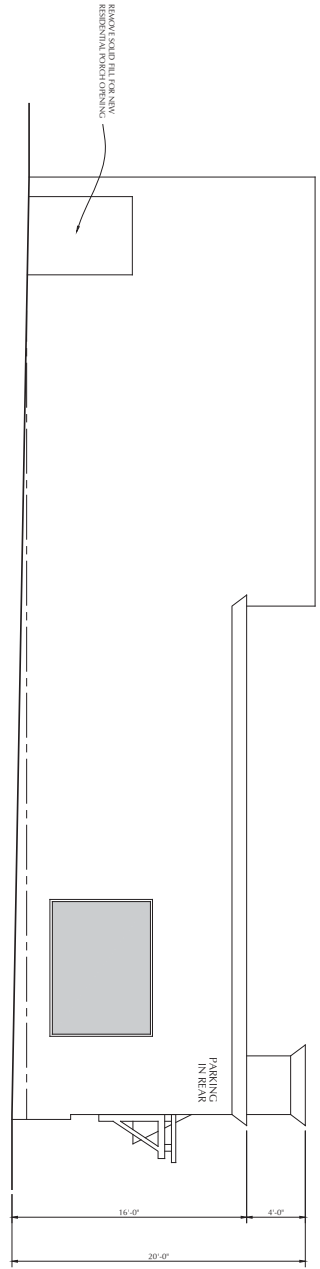

2 PROPOSED NORTH ELEVATION
SCALE: 1/8"=1'-0"

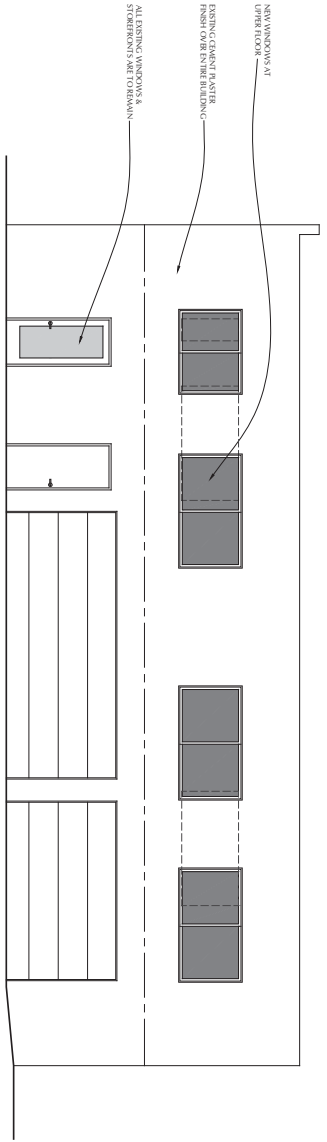

3 PROPOSED EAST ELEVATION
SCALE: 1/8"=1'-0"



WILLIAMS RESKIFF
ARCHITECT
9111 Center Street, Suite F
San Francisco, CA 94133
415.774.5555
www.wreskiff.com

TWO APARTMENT CONVERSION FOR
THE ALLEN PROPERTY GROUP
1360 41ST AVENUE, CAPITOLA, CALIFORNIA
PROPOSED EXTERIOR ELEVATIONS

DRAWING DATE: AUGUST 27, 2020
A.P.N.: 014-001716
CLIENT NAME: ALLEN PROPERTY GROUP, INC.
PROJECT NAME: 1360 41ST AVENUE

NO.	REVISION	DATE

NO.	REVISION	DATE

DATE: 09/15/2020
PROJECT: 1360 41ST AVENUE
DRAWING: EXTERIOR ELEVATIONS
SCALE: 1/8"=1'-0"

A3.1

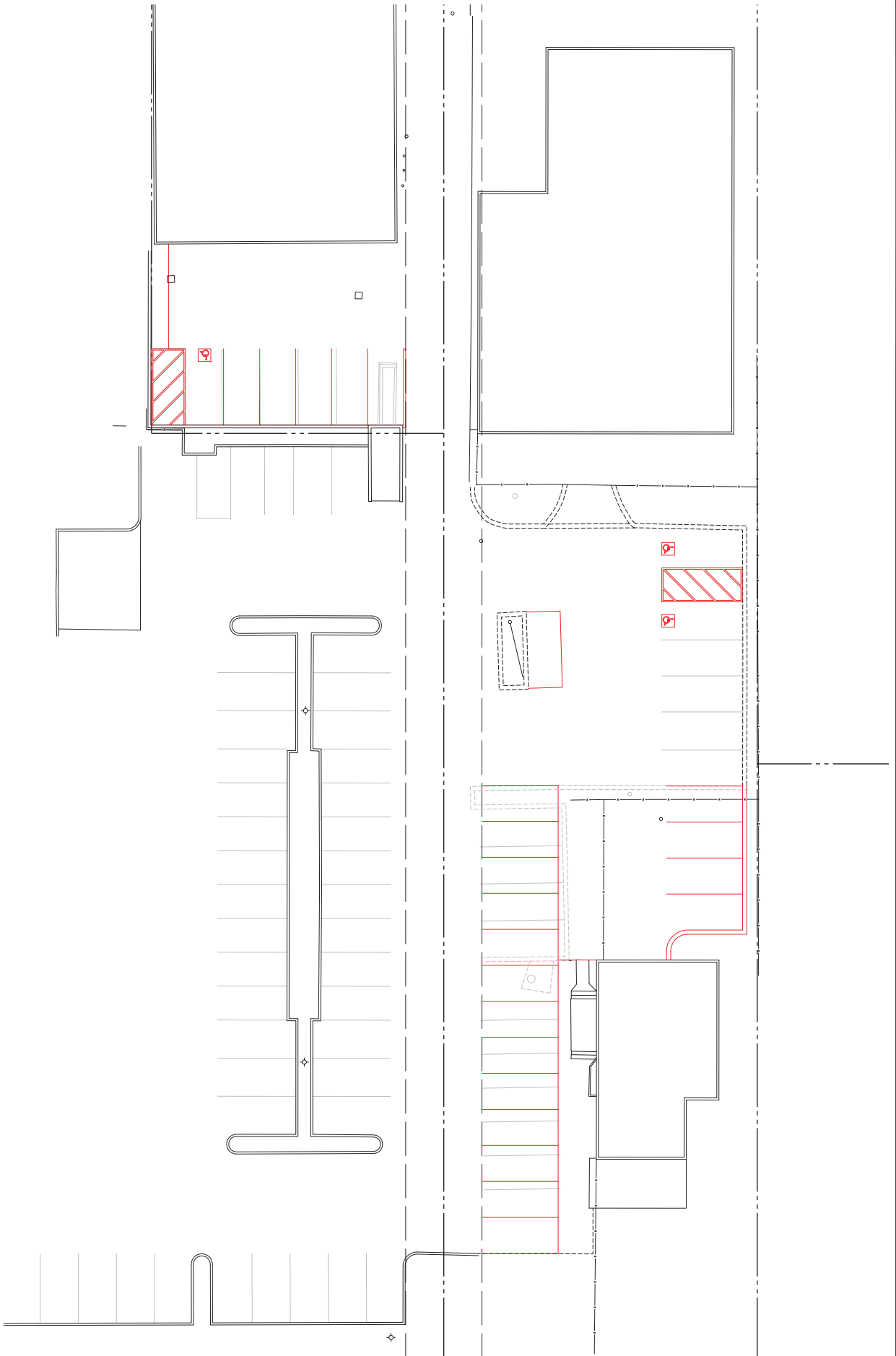

PARKING LOT PLAN
 SCALE: 1"=30'
 FEET

DATE:	AS NOTED
DESIGNED BY:	JR
DRAWN BY:	JR
DATE:	NOV. 6, 2019
REVISION:	DEC. 4, 2019
JOB NO.:	19045
SHEET:	

PARKING LOT IMPROVEMENTS FOR
 SANTA CRUZ BEACH LLC
 1360 & 1408 41ST AVE APN 034-101-16 & 034-111-36
 PARKING LOT PLAN



ROPER ENGINEERING
 CIVIL ENGINEERING & LAND SURVEYING
 64 PENNY LANE, SUITE A WATSONVILLE, CA 95076
 (831) 724-5300 jeff@roperengineering.com

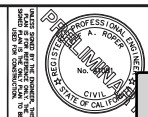



STAFF REPORT

TO: PLANNING COMMISSION

FROM: COMMUNITY DEVELOPMENT

DATE: NOVEMBER 5, 2020

SUBJECT: **Grand Avenue Pathway Improvements #20-0395**

Coastal Development Permit (CDP) for drainage improvements between Oakland and Hollister Avenues on the Grand Avenue Pathway in front of 100 Oakland Avenue and 404 Grand Avenue in the R-1 (Single-Family Residential) Zoning District.

This project is in the Coastal Zone and requires a Coastal Development Permit which is appealable to the California Coastal Commission after all possible appeals are exhausted through the City. Work was completed under an Emergency CDP.

Environmental Determination: Categorical Exemption

Property Owners: City of Capitola

Representative: John David, Filed: 09.23.20

APPLICANT PROPOSAL

The applicant is applying for a Coastal Development Permit (CDP) for drainage improvements on the Grand Avenue Pathway seaward of 100 Oakland Avenue and 404 Grand Avenue in the R-1 (Single-Family Residential) Zoning District. The improvements include the removal of failed landscaping and pathway structure, slope stabilization, and stormwater diversion.

BACKGROUND

Between November 30, 2019, and December 2, 2019, heavy rainfall fell on Capitola. By December 2, staff learned that a substantial bluff failure occurred below the Grand Avenue Pathway between Hollister and Oakland Avenues, resulting in the complete loss of a section of the pathway. Loss of the bluff through slides in this vicinity had been anticipated in 2017 when the Council authorized the closure of this section of the pathway due to ongoing slope failures in the area and potential impacts on the pathway.

Due in part to the closure, no one was harmed when the bluff failed. However, as a result of the slide, rain runoff from Hollister Avenue and surrounding properties, which previously had flowed down the pathway westerly toward a drainage inlet near Oakland Avenue, began falling directly onto the failed slope.

On December 3, 2019, based on this series of events, the City's Director of Emergency Services (the City Manager) issued a Proclamation of Existence of a Local Emergency.

On December 4, 2019, the City awarded an emergency contract to Anderson Pacific Engineering Construction to immediately construct and install a new drainage inlet on Hollister Avenue to divert the runoff away from the area of the slope failure. Anderson Pacific began work on December 4 and the work was completed by December 6.

On December 19, 2019, the Public Works Director presented a report on the Emergency Declaration to the Capitola City Council. The staff report included photos of the slope failure and emergency repairs.

On February 14, 2020, the Capitola Planning Commission approved a Coastal Development Permit for a new drainage inlet on the west side of Hollister Avenue (Attachment 1).

Since the installation of the new inlet, the failure site has continued to erode due to soil exposure and partial stormwater flow from the remaining pathway.

On September 28, 2020, the Community Development Director approved an Emergency Coastal Development Permit for the drainage improvements included under this application. The scope of work is included as Attachments 2 and 3.

If the work was completed, add when the work was done.

DISCUSSION

Pursuant to Section 17.46.050(A)(3)(a)(iii)(B) of the Capitola Municipal Code, a coastal development permit is required for repair and maintenance activities requiring “The presence, whether temporary or permanent, of mechanized construction equipment or construction materials on any sand area or bluff or environmentally sensitive habitat area as defined by the Coastal Act, or within twenty feet of coastal waters or streams.” The proposed work is adjacent to the bluff between Oakland Avenue and Hollister Avenue, therefore a coastal development permit is required.

The proposed drainage work is broken down into several components:

1. Demolition and removal of damaged pathway, private improvements, localized vegetation, and associated materials
2. Water diversion with a new hand-excavated trench for a concrete and asphalt ditch that will tie into City stormwater drainage systems on Oakland and Hollister Avenues.
3. Slope stabilization involving grading and soil compaction, compacted base rock surrounding the ditch, and turf reinforcement matting with hydroseed.
4. Landscaping of disturbed areas, fencing, and restoration of a stone retaining wall.

In response to the proposed work, the Coastal Commission recommended that the City process an emergency CDP to allow drainage work to begin immediately, but to postpone any additional work such as new fencing, landscaping, and retaining walls until after a CDP is issued by the Planning Commission. As a requirement of an emergency permit, the applicant must submit a completed application for a standard CDP within 30 days of emergency permit issuance (§17.46.130(D)). The work completed under the emergency permit must receive Planning Commission approval within 60 days unless granted an extension (§17.46.130(E)). The applicant submitted an application on September 24, 2020, in advance of the emergency permit issued by the City on September 28.

A condition of approval has been added to reflect a previous Coastal Commission recommendation from the prior Coastal Development Permit application for the new drainage inlet on the west side of Hollister Avenue:

1. To the extent safely possible, applicant shall attempt to remove any non-plant materials from the top of the bluff and along the bluff (e.g.: asphalt, plastic, sandbags, and fencing) to prevent these materials from falling onto the beach area and into the ocean.

Revocable Encroachment Permit

The proposed project is within the public right of way along a now-closed section of the Grand Avenue Pathway. Pursuant to Section 12.56.060(A), the City may issue permits for private improvements in the public right of way, to be installed and maintained by the applicant. Minor encroachment permits may also be approved by the Planning Commission in conjunction with other development applications. Typically, minor encroachment permits are issued for landscaping, driveways, fences, and similar improvements that do not exceed 42 inches in height. A condition has been added to ensure that no improvement exceeds the allowable height.

CEQA REVIEW

This project is categorically exempt under §15301 of the California Environmental Quality Act. The installation of the drainage improvements involves minor grading, replacement of hardscape materials, and landscaping.

RECOMMENDATION

Staff recommends the Planning Commission **approve** project application #20-0395 based on the following Conditions and Findings for Approval.

CONDITIONS OF APPROVAL

1. The project approval consists of construction of drainage improvements on the Grand Avenue Pathway in front of 100 Oakland Avenue and 404 Grand Avenue. The proposed project is approved as indicated on the final plans reviewed and approved by the Planning Commission on November 5, 2020, except as modified through conditions imposed by the Planning Commission during the hearing.
2. To the extent safely possible, applicant shall attempt to remove any non-plant materials from the top of the bluff and along the bluff (e.g.: asphalt, plastic, sandbags, and fencing) to prevent these materials from falling onto the beach area and into the ocean.
3. The proposed fence and concrete shall not exceed 42 inches in height.
4. The property owners at 100 Oakland Avenue and 404 Grand Avenue shall be responsible for the maintenance of all structures (concrete v-ditch, fences, etc.) constructed under this permit. The applicant must apply and obtain a Revocable Encroachment Permit for both 100 Oakland Avenue and 404 Grand Avenue (two applications) with the Public Works Department upon completion of structures or other improvements located in the public right of way.
5. All work within the public right of way shall be completed under an Encroachment Permit from the Public Works Department.

FINDINGS

- A. **The application, subject to the conditions imposed, will secure the purposes of the Zoning Ordinance, General Plan, and Local Coastal Plan.** Community Development Department Staff and the Planning Commission have reviewed the project. The proposed drainage improvements on the Grand Avenue

Pathway between Oakland and Hollister Avenues secure the purposes of the Zoning Ordinance, General Plan, and Local Coastal Plan.

B. The application will maintain the character and integrity of the neighborhood.

Community Development Department Staff and the Planning Commission have reviewed the application for drainage improvements on the Grand Avenue Pathway between Oakland and Hollister Avenues. The project will maintain the character and integrity of the neighborhood.

C. This project is categorically exempt under Section 15301 of the California Environmental Quality Act and is not subject to Section 753.5 of Title 14 of the California Code of Regulations.

Section 15301 of the CEQA Guidelines exempts the operation, repair, maintenance, permitting, leasing, licensing, or minor alteration of existing public or private structures, facilities, mechanical equipment, or topographical features, involving negligible or no expansion of existing or former use. This project involves drainage improvements on the Grand Avenue Pathway between Oakland and Hollister Avenues. No expansion of existing or former use is proposed. No adverse environmental impacts were discovered during review of the proposed project.

COASTAL FINDINGS

D. Findings Required.

1. **A coastal permit shall be granted only upon adoption of specific written factual findings supporting the conclusion that the proposed development conforms to the certified Local Coastal Program, including, but not limited to:**
 - a. A statement of the individual and cumulative burdens imposed on public access and recreation opportunities based on applicable factors identified pursuant to subsection (D)(2) of this section. The type of affected public access and recreation opportunities shall be clearly described;
 - b. An analysis based on applicable factors identified in subsection (D)(2) of this section of the necessity for requiring public access conditions to find the project consistent with the public access provisions of the Coastal Act;
 - c. A description of the legitimate governmental interest furthered by any access conditioned required;
 - d. An explanation of how imposition of an access dedication requirement alleviates the access burdens identified.
 - The proposed development conforms to the City's certified Local Coastal Plan (LCP). The specific, factual findings, as per CMC Section 17.46.090(D) are as follows:
2. **Require Project-Specific Findings. In determining any requirement for public access, including the type of access and character of use, the city shall evaluate and document in written findings the factors identified in subsections (D)(2)(a) through (e), to the extent applicable. The findings shall explain the basis for the conclusions and decisions of the city and shall be supported by substantial evidence in the record. If an access dedication is required as a condition of approval, the findings shall explain how the adverse effects which have been identified will be alleviated or mitigated by the dedication. As used in this section, "cumulative effect" means the effect of the individual project in combination with**

the effects of past projects, other current projects, and probable future projects, including development allowed under applicable planning and zoning.

- a. Project Effects on Demand for Access and Recreation. Identification of existing and open public access and coastal recreation areas and facilities in the regional and local vicinity of the development. Analysis of the project's effects upon existing public access and recreation opportunities. Analysis of the project's cumulative effects upon the use and capacity of the identified access and recreation opportunities, including public tidelands and beach resources, and upon the capacity of major coastal roads from subdivision, intensification or cumulative buildout. Projection for the anticipated demand and need for increased coastal access and recreation opportunities for the public. Analysis of the contribution of the project's cumulative effects to any such projected increase. Description of the physical characteristics of the site and its proximity to the sea, tideland viewing points, upland recreation areas, and trail linkages to tidelands or recreation areas. Analysis of the importance and potential of the site, because of its location or other characteristics, for creating, preserving or enhancing public access to tidelands or public recreation opportunities;
- The project area is over the final segment of Grand Avenue, the lateral access pathway that runs along the coastal edge of Depot Hill from Central Avenue to Hollister Avenue and provides public access to beautiful scenic views of the coastline. The pathway is situated on the edge of the coastal bluff, approximately 90 feet above a small strip of beach along the Monterey Bay.
 - Grand Avenue, which was formerly a city street with a walking path known as Lover's Lane on the seaward side (until the 1930's), has been utilized as a public walking path only from Central Avenue to Hollister Avenue for many years due to the precarious location of the road along the edge of the cliff.
 - The section of Grand Avenue pathway between Oakland Avenue and Hollister Avenue was closed in 2017 due to geologic instability to ensure public safety.
 - Due to significant rainfall in December 2019, the bluff below the Grand Avenue pathway between Hollister and Oakland Avenues failed, resulting in the complete loss of the pathway.
 - Since December 2019, surface stormwater that would have been directed along the Grand Avenue pathway in front of the properties between Oakland and Hollister Avenues has instead traveled through the primary failure cavity.
 - The project is supported by the following sections of the Local Coastal Program:
 - Policy II-1
 - It shall be the policy of the City of Capitola to provide safe and adequate pedestrian access to and along the shoreline as designated in the Shoreline Access Plan.
 - SEC. 30253
 1. Minimize risks to life and property in areas of high geologic, flood, and fire hazard.
 2. Assure stability and structural integrity, and neither create nor contribute significantly to erosion, geologic instability or destruction of the site or surrounding area or in any way require the construction of protective devices that would substantially alter natural landforms along cliffs and bluffs.
- b. Shoreline Processes. Description of the existing shoreline conditions, including beach profile, accessibility and usability of the beach, history of erosion or accretion, character and sources of sand, wave and sand movement, presence of shoreline

- protective structures, location of the line of mean high tide during the season when the beach is at its narrowest (generally during the late winter) and the proximity of that line to existing structures, and any other factors which substantially characterize or affect the shoreline processes at the site. Identification of anticipated changes to shoreline processes at the site. Identification of anticipated changes to shoreline processes and beach profile unrelated to the proposed development. Description and analysis of any reasonably likely changes, attributable to the primary and cumulative effects of the project, to: wave and sand movement affecting beaches in the vicinity of the project; the profile of the beach; the character, extent, accessibility and usability of the beach; and any other factors which characterize or affect beaches in the vicinity. Analysis of the effect of any identified changes of the project, alone or in combination with other anticipated changes, will have upon the ability of the public to use public tidelands and shoreline recreation areas;
- The project area is over the final segment of Grand Avenue, the lateral access pathway that runs along the coastal edge of Depot Hill from Central Avenue to Hollister Avenue and provides public access to beautiful scenic views of the coastline. The pathway is situated along the edge of the coastal bluff, approximately 90 feet above a small strip of beach along the Monterey Bay.
 - The project directs stormwater away from the area where the bluff failed in order to slow site erosion.
 - The project will not result in significant changes to shoreline processes.
- c. Historic Public Use. Evidence of use of the site by members of the general public for a continuous five-year period (such use may be seasonal). Evidence of the type and character of use made by the public (vertical, lateral, blufftop, etc., and for passive and/or active recreational use, etc.). Identification of any agency (or person) who has maintained and/or improved the area subject to historic public use and the nature of the maintenance performed and improvements made. Identification of the record owner of the area historically used by the public and any attempts by the owner to prohibit public use of the area, including the success or failure of those attempts. Description of the potential for adverse impact on public use of the area from the proposed development (including but not limited to, creation of physical or psychological impediments to public use);
- The project area is over the final segment of Grand Avenue, the lateral access pathway that runs along the coastal edge of Depot Hill from Central Avenue to Hollister Avenue and provides public access to beautiful scenic views of the coastline. As of 2017, the segment is no longer open to the public due to geologic instability and safety concerns.
- d. Physical Obstructions. Description of any physical aspects of the development which block or impede the ability of the public to get to or along the tidelands, public recreation areas, or other public coastal resources or to see the shoreline;
- The proposed project is located on public property over the final segment of Grand Avenue pathway between Oakland and Hollister Avenues. As of 2017, the project area is no longer open to the public due to geologic instability and safety concerns. The project will not expand the area that is physically obstructed from public access.

- e. Other Adverse Impacts on Access and Recreation. Description of the development's physical proximity and relationship to the shoreline and any public recreation area. Analysis of the extent of which buildings, walls, signs, streets or other aspects of the development, individually or cumulatively, are likely to diminish the public's use of tidelands or lands committed to public recreation. Description of any alteration of the aesthetic, visual or recreational value of public use areas, and of any diminution of the quality or amount of recreational use of public lands which may be attributable to the individual or cumulative effects of the development.
- The proposed project is located on public property that will not impact access and recreation. The project does not diminish the public's use of tidelands or lands committed to public recreation nor alter the aesthetic, visual, or recreational value of public use areas.
- 3. Required Findings for Public Access Exceptions. Any determination that one of the exceptions of subsection (F)(2) applies to a development shall be supported by written findings of fact, analysis and conclusions which address all of the following:**
- a. The type of access potentially applicable to the site involved (vertical, lateral, bluff top, etc.) and its location in relation to the fragile coastal resource to be protected, the agricultural use, the public safety concern, or the military facility which is the basis for the exception, as applicable;
 - b. Unavailability of any mitigating measures to manage the type, character, intensity, hours, season or location of such use so that agricultural resources, fragile coastal resources, public safety, or military security, as applicable, are protected;
 - c. Ability of the public, through another reasonable means, to reach the same area of public tidelands as would be made accessible by an accessway on the subject land.
- The project is not requesting a Public Access Exception, therefore these findings do not apply.
- 4. Findings for Management Plan Conditions. Written findings in support of a condition requiring a management plan for regulating the time and manner or character of public access use must address the following factors, as applicable:**
- a. Identification and protection of specific habitat values including the reasons supporting the conclusions that such values must be protected by limiting the hours, seasons, or character of public use;
 - The project is located in a residential area without sensitive habitat areas.
 - b. Topographic constraints of the development site;
 - The project is located on a blufftop.
 - c. Recreational needs of the public;
 - The project does not impact the recreational needs of the public.
 - d. Rights of privacy of the landowner which could not be mitigated by setting the project back from the access way or otherwise conditioning the development;

- e. The requirements of the possible accepting agency, if an offer of dedication is the mechanism for securing public access;
- f. Feasibility of adequate setbacks, fencing, landscaping, and other methods as part of a management plan to regulate public use.

5. Project complies with public access requirements, including submittal of appropriate legal documents to ensure the right of public access whenever, and as, required by the certified land use plan and Section 17.46.010 (coastal access requirements);

- No legal documents to ensure public access rights are required for the proposed project.

6. Project complies with visitor-serving and recreational use policies;

SEC. 30222

The use of private lands suitable for visitor-serving commercial recreational facilities designed to enhance public opportunities for coastal recreation shall have priority over private residential, general industrial, or general commercial development, but not over agriculture or coastal-dependent industry.

- The project involves debris cleanup and drainage improvements in the public right-of-way between Oakland and Hollister Avenues over what was formerly the final segment of the Grand Avenue pathway.

SEC. 30223

Upland areas necessary to support coastal recreational uses shall be reserved for such uses, where feasible.

- The project involves debris cleanup and drainage improvements in the public right-of-way between Oakland and Hollister Avenues over what was formerly the final segment of the Grand Avenue pathway. The area is already inaccessible to the public due to geologic instability and safety concerns.

c) Visitor-serving facilities that cannot be feasibly located in existing developed areas shall be located in existing isolated developments or at selected points of attraction for visitors.

- The project involves debris cleanup and drainage improvements in the public right-of-way between Oakland and Hollister Avenues over what was formerly the final segment of the Grand Avenue pathway. The area is already inaccessible to the public due to geologic instability and safety concerns.

7. Project complies with applicable standards and requirements for provision of public and private parking, pedestrian access, alternate means of transportation and/or traffic improvements;

- The project involves debris cleanup and drainage improvements in the public right-of-way between Oakland and Hollister Avenues over what was formerly the final segment of the Grand Avenue pathway. The project complies with

applicable standards and requirements for provisions for parking, pedestrian access, alternate means of transportation, and/or traffic improvements.

8. Review of project design, site plan, signing, lighting, landscaping, etc., by the city's architectural and site review committee, and compliance with adopted design guidelines and standards, and review committee recommendations;

- The project complies with the design guidelines and standards established by the Capitola Municipal Code.

9. Project complies with LCP policies regarding protection of public landmarks, protection or provision of public views; and shall not block or detract from public views to and along Capitola's shoreline;

- The project will not negatively impact public landmarks and/or public views. The project will not block or detract from public views to and along Capitola's shoreline.

10. Demonstrated availability and adequacy of water and sewer services;

- Not applicable.

11. Provisions of minimum water flow rates and fire response times;

- Not applicable.

12. Project complies with water and energy conservation standards;

- Not applicable.

13. Provision of park dedication, school impact, and other fees as may be required;

- Not applicable.

14. Project complies with coastal housing policies, and applicable ordinances including condominium conversion and mobile home ordinances;

- The project does not involve a condo conversion or mobile homes.

15. Project complies with natural resource, habitat, and archaeological protection policies;

- Conditions of approval have been included to ensure compliance with established policies.

16. Project complies with Monarch butterfly habitat protection policies;

- The project is outside of any identified sensitive habitats, specifically areas where Monarch Butterflies have been encountered, identified, and documented.

17. Project provides drainage and erosion and control measures to protect marine, stream, and wetland water quality from urban runoff and erosion;

- Conditions of approval have been included to ensure compliance with applicable erosion control measures.

18. Geologic/engineering reports have been prepared by qualified professional for projects in seismic areas, geologically unstable areas, or coastal bluffs, and project complies with hazard protection policies including provision of appropriate setbacks and mitigation measures;

- Review of the bluff instability was prepared for the previous CDP for drainage improvements in the same location, which was approved by the Capitola Planning Commission on February 6, 2020. The current proposal facilitates the stormwater plan previously described, diverting any drainage not captured by the new Hollister Avenue drainage inlet and outfall to the existing inlet and outfall between Saxon Avenue and Oakland Avenue.

19. All other geological, flood and fire hazards are accounted for and mitigated in the project design;

- Conditions of approval have been included to ensure the project complies with geological, flood, and fire hazards and are accounted for and will be mitigated in the project design.

20. Project complies with shoreline structure policies;

- The proposed project complies with shoreline structure policies.

21. The uses proposed are consistent with the permitted or conditional uses of the zoning district in which the project is located;

- Not applicable.

22. Conformance to requirements of all other city ordinances, zoning requirements, and project review procedures; and

- The project conforms to the requirements of all city ordinances, zoning requirements, and project development review and development procedures.

23. Project complies with the Capitola parking permit program as follows:

- a. The village area preferential parking program areas and conditions as established in Resolution No. 2596 and no permit parking of any kind shall be allowed on Capitola Avenue.
- b. The neighborhood preferential parking program areas are as established in Resolution Numbers 2433 and 2510.
- c. The village area preferential parking program shall be limited to three hundred fifty permits.
- d. Neighborhood permit areas are only in force when the shuttle bus is operating except that:
 - i. The Fanmar area (Resolution No. 2436) program may operate year-round, twenty-four hours a day on weekends,

- ii. The Burlingame, Cliff Avenue/Grand Avenue area (Resolution No. 2435) have year-round, twenty-four hour per day “no public parking.”
 - e. Except as specifically allowed under the village parking program, no preferential residential parking may be allowed in the Cliff Drive parking areas.
 - f. Six Depot Hill twenty-four minute “Vista” parking spaces (Resolution No. 2510) shall be provided as corrected in Exhibit A attached to the ordinance codified in this section and found on file in the office of the city clerk.
 - g. A limit of fifty permits for the Pacific Cove parking lot may be issued to village permit holders and transient occupancy permit holders.
 - h. No additional development in the village that intensifies use and requires additional parking shall be permitted. Changes in use that do not result in additional parking demand can be allowed and exceptions for onsite parking as allowed in the land use plan can be made.
- Not applicable.

ATTACHMENTS:

1. Grand Avenue Pathway - PC Staff Report - 02.06.2020
2. 100 Oakland & 404 Grand Avenue - Plan Set
3. 100 Oakland & 404 Grand Avenue - Work Synopsis

Prepared By: Sean Sesanto



STAFF REPORT

TO: PLANNING COMMISSION

FROM: COMMUNITY DEVELOPMENT

DATE: FEBRUARY 6, 2020

SUBJECT: **Grand Avenue Pathway Drainage Improvements #20-0014**

Coastal Development Permit (CDP) for drainage improvements on Hollister Avenue near the Grand Avenue Pathway in the R-1 (Single-Family Residential) Zoning District. The improvements include a new drainage inlet on the west side of Hollister Avenue.

This project is in the Coastal Zone and requires a Coastal Development Permit which is appealable to the California Coastal Commission after all possible appeals are exhausted through the City. Work was completed under an Emergency CDP.

Environmental Determination: Categorical Exemption

Property Owner: City of Capitola

Representative: Steve Jesberg, Filed: 01.17.2020

APPLICANT PROPOSAL

The City of Capitola is applying for a Coastal Development Permit (CDP) for drainage improvements on Hollister Avenue near the Grand Avenue Pathway in the R-1 (Single-Family Residential) Zoning District. The improvements include a new drainage inlet on the west side of Hollister Avenue.

BACKGROUND

Between Saturday, November 30, 2019, and Monday, December 2, 2019, approximately seven inches of rain fell in the Capitola area. At noon on December 2, Public Works staff learned the bluff below the Grand Avenue pathway between Hollister and Oakland Avenues had failed, resulting in complete loss of a section of the pathway. Loss of the bluff through slides in this vicinity had been anticipated in 2017 when the City Council authorized the closure of this section of the pathway due to ongoing slope failures in the area and potential impacts on the pathway.

Due in part to the closure, no one was harmed when the bluff slid and a section of the path was lost. However, as a result of the slide, rain runoff from Hollister Avenue and surrounding properties, which previously had flowed down the pathway westerly toward a drainage inlet near Oakland Avenue, began flowing directly onto the failed slope.

On December 3, 2019, based on this series of events, the City's Director of Emergency Services (the City Manager) issued a Proclamation of Existence of a Local Emergency (Attachment 1).

On December 4, 2019, the City awarded an emergency contract to Anderson Pacific Engineering Construction to immediately construct and install a new drainage inlet on Hollister Avenue to divert the runoff away from the area of the slope failure (Attachment 1). Anderson Pacific began work on December 4 and the work was completed by December 6.

On December 19, 2019, the Public Works Director presented a report on the Emergency Declaration to the Capitola City Council. The staff report, which includes photos of the slope failure and emergency repairs, are included as Attachment 1.

On December 16, 2019, the Coastal Commission submitted a comment letter on the Emergency Declaration (Attachment 2).

DISCUSSION

The proposed project includes the drainage improvements completed under the Emergency CDP. Pursuant to Section 17.46.050(A)(3)(a)(iii)(B) of the Capitola Municipal Code, a coastal development permit is required for repair and maintenance activities requiring “The presence, whether temporary or permanent, of mechanized construction equipment or construction materials on any sand area or bluff or environmentally sensitive habitat area as defined by the Coastal Act, or within twenty feet of coastal waters or streams.” The proposed work is adjacent to the bluff at the end of Hollister Avenue, therefore a coastal development permit is required.

In the December 16, 2019, letter, the Coastal Commission recommended that the City “process an emergency CDP as soon as possible for any work that has already been done, and for any additional work still necessary to abate the emergency situation (e.g., removing any fencing, asphalt, etc.; installation of drainage components and plastic sheeting on the bluff area,” and encouraged the City “to remove any non-plant materials from the top of the bluff and along the bluff (e.g.: asphalt, plastic, sand bags, and fencing) to prevent these materials from falling onto the beach area and ultimately into the ocean.”

The Coastal Commission also included a list of items that should be included in a follow-up CDP to authorize the work done under the Emergency CDP. The list includes: examining what level of storm the existing drainage inlets can accommodate; considering additional drainage improvements to prevent runoff down the bluff and exploring other measures that may be suitable to prevent/reduce erosion in the area; and examining the feasibility of reclaiming the public right-of-way to allow for a through public pathway, even if such a path could only exist for a relatively short planning horizon (e.g., 5-20 years) and is a more informal pathway (e.g., compacted dirt, decomposed granite, etc. as opposed to concrete or asphalt). An analysis of the eroded cliff shows that the cliff face is now within 3-5 feet of the private property line making it infeasible to safely establish a new pathway in this area on the road right of way.

Several conditions of approval have been added to reflect the Coastal Commission recommendations, including:

2. To the extent safely possible, applicant shall attempt to remove any non-plant materials from the top of the bluff and along the bluff (e.g.: asphalt, plastic, sandbags, and fencing) to prevent these materials from falling onto the beach area and into the ocean.
3. Applicant shall submit the following information to the Coastal Commission:
 - a. The level of storm the existing drainage inlets can accommodate; and
 - b. A preliminary analysis of additional possible drainage improvements to prevent runoff down the bluff and any other measures that may be suitable to prevent/reduce erosion in the area.

CEQA

This project is categorically exempt under §15304(f) of the California Environmental Quality Act. Installation of the drainage improvements involved minor trenching and backfilling where the surface was restored.

RECOMMENDATION

Staff recommends approval of a Coastal Development Permit for Application #20-0014 based on the findings and conditions.

CONDITIONS OF APPROVAL

1. The project approval consists of construction of drainage improvements on Hollister Avenue near the Grand Avenue Pathway. The proposed project is approved as indicated on the final plans reviewed and approved by the Planning Commission on February 6, 2020, except as modified through conditions imposed by the Planning Commission during the hearing.
2. To the extent safely possible, applicant shall attempt to remove any non-plant materials from the top of the bluff and along the bluff (e.g.: asphalt, plastic, sandbags, and fencing) to prevent these materials from falling onto the beach area and into the ocean.
3. Applicant shall submit the following information to the Coastal Commission:
 - a. The level of storm the existing drainage inlets can accommodate; and
 - b. A preliminary analysis of additional possible drainage improvements to prevent runoff down the bluff and any other measures that may be suitable to prevent/reduce erosion in the area.

FINDINGS**A. The project, subject to the conditions imposed, secures the purposes of the Zoning Ordinance, General Plan, and Local Coastal Plan.**

Community Development Staff and the Planning Commission have reviewed the project. The proposed construction of drainage improvements on Hollister Avenue near the Grand Avenue Pathway secures the purpose of the Zoning Ordinance, General Plan, and Local Coastal Plan.

B. The project will maintain the character and integrity of the neighborhood.

Community Development Staff and the Planning Commission have reviewed the application for construction of drainage improvements on Hollister Avenue near the Grand Avenue Pathway. The project will maintain the character and integrity of the neighborhood.

C. This project is categorically exempt under Section 15304(f) of the California Environmental Quality Act and is subject to Section 753.5 of Title 14 of the California Code of Regulations.

Section 15304(f) of the CEQA Guidelines exempts minor trenching and backfilling where the surface is restored. This project involves construction of drainage improvements on Hollister Avenue near the Grand Avenue Pathway. No adverse environmental impacts were discovered during review of the proposed project.

COASTAL FINDINGS**D. Findings Required.**

1. **A coastal permit shall be granted only upon adoption of specific written factual findings supporting the conclusion that the proposed development conforms to the certified Local Coastal Program, including, but not limited to:**

- a. A statement of the individual and cumulative burdens imposed on public access and recreation opportunities based on applicable factors identified pursuant to subsection (D)(2) of this section. The type of affected public access and recreation opportunities shall be clearly described;
- b. An analysis based on applicable factors identified in subsection (D)(2) of this section of the necessity for requiring public access conditions to find the project consistent with the public access provisions of the Coastal Act;
- c. A description of the legitimate governmental interest furthered by any access conditioned required;
- d. An explanation of how imposition of an access dedication requirement alleviates the access burdens identified.
 - The proposed development conforms to the City's certified Local Coastal Plan (LCP). The specific, factual findings, as per CMC Section 17.46.090(D) are as follows:

2. Require Project-Specific Findings. In determining any requirement for public access, including the type of access and character of use, the city shall evaluate and document in written findings the factors identified in subsections (D)(2)(a) through (e), to the extent applicable. The findings shall explain the basis for the conclusions and decisions of the city and shall be supported by substantial evidence in the record. If an access dedication is required as a condition of approval, the findings shall explain how the adverse effects which have been identified will be alleviated or mitigated by the dedication. As used in this section, "cumulative effect" means the effect of the individual project in combination with the effects of past projects, other current projects, and probable future projects, including development allowed under applicable planning and zoning.

- a. Project Effects on Demand for Access and Recreation. Identification of existing and open public access and coastal recreation areas and facilities in the regional and local vicinity of the development. Analysis of the project's effects upon existing public access and recreation opportunities. Analysis of the project's cumulative effects upon the use and capacity of the identified access and recreation opportunities, including public tidelands and beach resources, and upon the capacity of major coastal roads from subdivision, intensification or cumulative buildout. Projection for the anticipated demand and need for increased coastal access and recreation opportunities for the public. Analysis of the contribution of the project's cumulative effects to any such projected increase. Description of the physical characteristics of the site and its proximity to the sea, tideland viewing points, upland recreation areas, and trail linkages to tidelands or recreation areas. Analysis of the importance and potential of the site, because of its location or other characteristics, for creating, preserving or enhancing public access to tidelands or public recreation opportunities;
 - The project area is adjacent to the final segment of Grand Avenue, the lateral access pathway that runs along the coastal edge of Depot Hill from Central Avenue to Hollister Avenue and provides public access to beautiful scenic views of the coastline. The pathway is situated the edge of the coastal bluff, approximately 90 feet above a small strip of beach along the Monterey Bay.
 - Grand Avenue, which was formerly a city street with a walking path known as Lover's Lane on the seaward side (until the 1930's), has been utilized as a public walking path only from Central Avenue to Hollister Avenue for many years due to the precarious location of the road along the edge of the cliff.

- The section of the Grand Avenue pathway between Oakland Avenue and Hollister Avenue was closed in 2017 due to geologic instability to ensure public safety.
 - Due to significant rainfall in December 2019, the bluff below the Grand Avenue pathway between Hollister and Oakland Avenues failed, resulting in complete loss of the pathway.
 - The project directs stormwater away from the area where the bluff failed to slow down erosion in the area.
 - The project is supported by the following sections of the Local Coastal Program:
 - Policy II-1
 - It shall be the policy of the City of Capitola to provide safe and adequate pedestrian access to and along the shoreline as designated in the Shoreline Access Plan.
 - SEC. 30253
 1. Minimize risks to life and property in areas of high geologic, flood, and fire hazard.
 2. Assure stability and structural integrity, and neither create nor contribute significantly to erosion, geologic instability, or destruction of the site or surrounding area or in any way require the construction of protective devices that would substantially alter natural landforms along cliffs and bluffs.
- b. Shoreline Processes. Description of the existing shoreline conditions, including beach profile, accessibility and usability of the beach, history of erosion or accretion, character and sources of sand, wave and sand movement, presence of shoreline protective structures, location of the line of mean high tide during the season when the beach is at its narrowest (generally during the late winter) and the proximity of that line to existing structures, and any other factors which substantially characterize or affect the shoreline processes at the site. Identification of anticipated changes to shoreline processes at the site. Identification of anticipated changes to shoreline processes and beach profile unrelated to the proposed development. Description and analysis of any reasonably likely changes, attributable to the primary and cumulative effects of the project, to: wave and sand movement affecting beaches in the vicinity of the project; the profile of the beach; the character, extent, accessibility and usability of the beach; and any other factors which characterize or affect beaches in the vicinity. Analysis of the effect of any identified changes of the project, alone or in combination with other anticipated changes, will have upon the ability of the public to use public tidelands and shoreline recreation areas;
- The project area is adjacent to the final segment of Grand Avenue, the lateral access pathway that runs along the coastal edge of Depot Hill from Central Avenue to Hollister Avenue and provides public access to beautiful scenic views of the coastline. The pathway is situated the edge of the coastal bluff, approximately 90 feet above a small strip of beach along the Monterey Bay.
 - The project directs stormwater away from the area where the bluff failed to slow down erosion in the area.
 - The project will not result in significant changes to shoreline processes.
- c. Historic Public Use. Evidence of use of the site by members of the general public for a continuous five-year period (such use may be seasonal). Evidence of the type and character of use made by the public (vertical, lateral, blufftop, etc., and for passive

- and/or active recreational use, etc.). Identification of any agency (or person) who has maintained and/or improved the area subject to historic public use and the nature of the maintenance performed and improvements made. Identification of the record owner of the area historically used by the public and any attempts by the owner to prohibit public use of the area, including the success or failure of those attempts. Description of the potential for adverse impact on public use of the area from the proposed development (including but not limited to, creation of physical or psychological impediments to public use);
- The project area is adjacent to the final segment of Grand Avenue, the lateral access pathway that runs along the coastal edge of Depot Hill from Central Avenue to Hollister Avenue and provides public access to beautiful scenic views of the coastline from the blufftop.
- d. Physical Obstructions. Description of any physical aspects of the development which block or impede the ability of the public to get to or along the tidelands, public recreation areas, or other public coastal resources or to see the shoreline;
- The proposed project is located on public property at the end of Hollister Avenue near the Grand Avenue Pathway. The project will not block or impede the ability of the public to get to or along the tidelands, public recreation areas, or views to the shoreline.
- e. Other Adverse Impacts on Access and Recreation. Description of the development's physical proximity and relationship to the shoreline and any public recreation area. Analysis of the extent of which buildings, walls, signs, streets or other aspects of the development, individually or cumulatively, are likely to diminish the public's use of tidelands or lands committed to public recreation. Description of any alteration of the aesthetic, visual or recreational value of public use areas, and of any diminution of the quality or amount of recreational use of public lands which may be attributable to the individual or cumulative effects of the development.
- The proposed project is located on public property that will not impact access and recreation. The project does not diminish the public's use of tidelands or lands committed to public recreation nor alter the aesthetic, visual, or recreational value of public use areas.
- 3. Required Findings for Public Access Exceptions. Any determination that one of the exceptions of subsection (F)(2) applies to a development shall be supported by written findings of fact, analysis and conclusions which address all of the following:**
- a. The type of access potentially applicable to the site involved (vertical, lateral, bluff top, etc.) and its location in relation to the fragile coastal resource to be protected, the agricultural use, the public safety concern, or the military facility which is the basis for the exception, as applicable;
 - b. Unavailability of any mitigating measures to manage the type, character, intensity, hours, season or location of such use so that agricultural resources, fragile coastal resources, public safety, or military security, as applicable, are protected;
 - c. Ability of the public, through another reasonable means, to reach the same area of public tidelands as would be made accessible by an accessway on the subject land.

- The project is not requesting a Public Access Exception, therefore these findings do not apply.
4. **Findings for Management Plan Conditions. Written findings in support of a condition requiring a management plan for regulating the time and manner or character of public access use must address the following factors, as applicable:**
- a. Identification and protection of specific habitat values including the reasons supporting the conclusions that such values must be protected by limiting the hours, seasons, or character of public use;
 - The project is located in a residential area without sensitive habitat areas.
 - b. Topographic constraints of the development site;
 - The project is located on a blufftop.
 - c. Recreational needs of the public;
 - The project does not impact the recreational needs of the public.
 - d. Rights of privacy of the landowner which could not be mitigated by setting the project back from the access way or otherwise conditioning the development;
 - e. The requirements of the possible accepting agency, if an offer of dedication is the mechanism for securing public access;
 - f. Feasibility of adequate setbacks, fencing, landscaping, and other methods as part of a management plan to regulate public use.
5. **Project complies with public access requirements, including submittal of appropriate legal documents to ensure the right of public access whenever, and as, required by the certified land use plan and Section 17.46.010 (coastal access requirements);**
- No legal documents to ensure public access rights are required for the proposed project.
6. **Project complies with visitor-serving and recreational use policies;**

SEC. 30222

The use of private lands suitable for visitor-serving commercial recreational facilities designed to enhance public opportunities for coastal recreation shall have priority over private residential, general industrial, or general commercial development, but not over agriculture or coastal-dependent industry.

- The project involves construction of drainage improvements in the public right-of-way on Hollister Avenue near the Grand Avenue Pathway.

SEC. 30223

Upland areas necessary to support coastal recreational uses shall be reserved for such uses, where feasible.

- The project involves construction of drainage improvements in the public right-of-way on Hollister Avenue near the Grand Avenue Pathway.

c) Visitor-serving facilities that cannot be feasibly located in existing developed areas shall be located in existing isolated developments or at selected points of attraction for visitors.

- The project involves construction of drainage improvements in the public right-of-way on Hollister Avenue near the Grand Avenue Pathway.

7. Project complies with applicable standards and requirements for provision of public and private parking, pedestrian access, alternate means of transportation and/or traffic improvements;

- The project involves the construction of drainage improvements in the public right-of-way on Hollister Avenue. The project complies with applicable standards and requirements for provision for parking, pedestrian access, alternate means of transportation, and/or traffic improvements.

8. Review of project design, site plan, signing, lighting, landscaping, etc., by the city's architectural and site review committee, and compliance with adopted design guidelines and standards, and review committee recommendations;

- The project complies with the design guidelines and standards established by the Municipal Code.

9. Project complies with LCP policies regarding protection of public landmarks, protection or provision of public views; and shall not block or detract from public views to and along Capitola's shoreline;

- The project will not negatively impact public landmarks and/or public views. The project will not block or detract from public views to and along Capitola's shoreline.

10. Demonstrated availability and adequacy of water and sewer services;

- Not Applicable

11. Provisions of minimum water flow rates and fire response times;

- Not Applicable

12. Project complies with water and energy conservation standards;

- Not Applicable

13. Provision of park dedication, school impact, and other fees as may be required;

- Not Applicable

14. Project complies with coastal housing policies, and applicable ordinances including condominium conversion and mobile home ordinances;

- The project does not involve a condo conversion or mobile homes.
- 15. Project complies with natural resource, habitat, and archaeological protection policies;**
- Conditions of approval have been included to ensure compliance with established policies.
- 16. Project complies with Monarch butterfly habitat protection policies;**
- The project is outside of any identified sensitive habitats, specifically areas where Monarch Butterflies have been encountered, identified and documented.
- 17. Project provides drainage and erosion and control measures to protect marine, stream, and wetland water quality from urban runoff and erosion;**
- Conditions of approval have been included to ensure compliance with applicable erosion control measures.
- 18. Geologic/engineering reports have been prepared by qualified professional for projects in seismic areas, geologically unstable areas, or coastal bluffs, and project complies with hazard protection policies including provision of appropriate setbacks and mitigation measures;**
- Geologic/engineering reports have been prepared by qualified professionals for this project.
- 19. All other geological, flood and fire hazards are accounted for and mitigated in the project design;**
- Conditions of approval have been included to ensure the project complies with geological, flood, and fire hazards and are accounted for and will be mitigated in the project design.
- 20. Project complies with shoreline structure policies;**
- The proposed project complies with shoreline structure policies.
- 21. The uses proposed are consistent with the permitted or conditional uses of the zoning district in which the project is located;**
- Not Applicable
- 22. Conformance to requirements of all other city ordinances, zoning requirements, and project review procedures; and**
- The project conforms to the requirements of all city ordinances, zoning requirements, and project development review and development procedures.
- 23. Project complies with the Capitola parking permit program as follows:**

- a. The village area preferential parking program areas and conditions as established in Resolution No. 2596 and no permit parking of any kind shall be allowed on Capitola Avenue.
 - b. The neighborhood preferential parking program areas are as established in Resolution Numbers 2433 and 2510.
 - c. The village area preferential parking program shall be limited to three hundred fifty permits.
 - d. Neighborhood permit areas are only in force when the shuttle bus is operating except that:
 - i. The Fanmar area (Resolution No. 2436) program may operate year-round, twenty-four hours a day on weekends,
 - ii. The Burlingame, Cliff Avenue/Grand Avenue area (Resolution No. 2435) have year-round, twenty-four hour per day “no public parking.”
 - e. Except as specifically allowed under the village parking program, no preferential residential parking may be allowed in the Cliff Drive parking areas.
 - f. Six Depot Hill twenty-four minute “Vista” parking spaces (Resolution No. 2510) shall be provided as corrected in Exhibit A attached to the ordinance codified in this section and found on file in the office of the city clerk.
 - g. A limit of fifty permits for the Pacific Cove parking lot may be issued to village permit holders and transient occupancy permit holders.
 - h. No additional development in the village that intensifies use and requires additional parking shall be permitted. Changes in use that do not result in additional parking demand can be allowed and exceptions for onsite parking as allowed in the land use plan can be made.
- Not Applicable

ATTACHMENTS:

1. Grand Avenue Pathway Closure - Emergency CDP - CC Staff Report and Attachments - 12.19.2019
2. Grand Avenue Pathway - Coastal Commission Letter - CC Hearing Item # 10A - 12.19.2019
3. Grand Avenue Pathway - Drain Line Cross Sections
4. Grand Avenue Pathway - Drainage Improvements Overview

Prepared By: Matt Orbach
Associate Planner



CAPITOLA CITY COUNCIL AGENDA REPORT

MEETING OF DECEMBER 19, 2019

FROM: Public Works Department

SUBJECT: Report on Emergency Declaration from December 3, 2019

RECOMMENDED ACTION: Receive a report on a Proclamation of Existence of a Local Emergency made by the City Director of Emergency Services on December 3, 2019, in response damages to the Grand Avenue Pathway following heavy rains, and authorize associated expenditures from Measure F funding.

BACKGROUND: Between Saturday, November 30, 2019, and Monday, December 2, 2019, approximately seven inches of rain fell in the Capitola area. At noon on December 2, Public Works staff learned the bluff below the Grand Avenue pathway between Hollister and Oakland Avenues had failed, resulting in complete loss of the pathway. Further slides in this vicinity had been anticipated back in 2017 when the Council authorized the closure of this section of the pathway due to ongoing slope failures in the area and potential impacts on the pathway.

Due in part to the closure, no one was harmed when the path failed. However, as a result of the failure, rain runoff from Hollister Avenue and surrounding properties, which previously had flowed down the pathway westerly toward a drainage inlet near Oakland Avenue, began falling directly onto the failed slope.

Based on this series of events, on December 3, the City's Director of Emergency Services (the City Manager) issued a Proclamation of Existence of a Local Emergency.

DISCUSSION: Capitola Municipal Code Section 8.08.050 states that, in times of emergency, the City Manager is the Director of Emergency Services. Section 8.08.060 authorizes the City Manager, in that capacity, to issue a proclamation of emergency if there is an emergency and the Council is not in session. On December 3, for the reasons stated above, the City Manager, acting as the Director of Emergency Services, issued a Proclamation of Existence of a Local Emergency. A copy of the proclamation is included as Attachment 1.

On December 4, 2019, the City awarded an emergency contract to Anderson Pacific Engineering Construction to immediately construct and install a new drainage inlet on Hollister Avenue to divert the runoff away from the area of the slope failure. A copy of the contract is included as Attachment 2. Anderson Pacific began work on December 4 and the work was completed by December 6. Anderson Pacific completed the work on a force account basis, meaning the project costs were be calculated based on time, materials, and equipment costs plus a standard markup used and approved by Caltrans. This type of contract is typical for emergency work. While the City has not received the final billing from Anderson Pacific, staff estimates costs at \$20,000.

Grand Ave Storm Damage Report
December 19, 2019

Finally, on December 5, 2019, a property owner adjacent to the pathway installed a plastic sheet over the area of the slope failure.

Photos of the slope failure and emergency repairs are included as Attachment 3.

FISCAL IMPACT: Under the authority of the emergency declaration, the City Manager has preliminarily directed the payment of the emergency work from the Emergency Reserves. However, staff recommends the project costs be allocated to Measure F funds, which have been set aside for ocean-related resiliency projects. These funds currently are being held for flume, jetty, and wharf improvements and total just over \$1 million. The added expense of the emergency work will not impact the planned projects.

ATTACHMENTS:

1. Local Emergency Declaration 12032019
2. Anderson Pacific Emergency Contract
3. Grand Avenue Pathway Photographs

Report Prepared By: Steve Jesberg
Public Works Director

Reviewed and Forwarded by:



Jamie Goldstein, City Manager

12/12/2019

BY THE DIRECTOR OF EMERGENCY SERVICES OF THE
CITY OF CAPITOLA

Proclamation of Existence of a Local Emergency

WHEREAS, Municipal Code Section 8.08.050 empowers the Director of Emergency Services for the City of Capitola to proclaim the existence of a local emergency when said City is affected or likely to be affected by the existence of disaster or extreme peril which is, or is likely to be, beyond the control of the services, personnel, equipment and facilities of this City, requiring the combined forces of other political subdivisions to control; and

WHEREAS, the Director of Emergency Services does hereby find:

That conditions of extreme peril to the safety of persons and property have arisen on December 3, 2019 within the City of Capitola as a result of more than 7 inches of rain, thereby causing damage to the Grand Avenue pathway and directing drainage directly onto the unstable bluff face which could cause further bluff failures if not immediately abated.

That the aforesaid conditions of extreme peril warrant and necessitate the proclamation of the existence of a local emergency;

That the City Council of the City of Capitola is not in session.

NOW, THEREFORE, BE IT HEREBY PROCLAIMED that during the existence of said local emergency the powers, functions, and duties of the Director of Emergency Services and the emergency organization of the City of Capitola, Santa Cruz County, California, shall be those prescribed by State law, by ordinances and resolutions of the City; and

IT IS FURTHER PROCLAIMED AND ORDERED that said local emergency shall be deemed to continue to exist for a period of seven days and shall thereupon terminate unless this proclamation is ratified and continued in effect by the City Council of the City of Capitola.

Date: 12/3/19

BENJAMIN GOLDSTEIN
Director of Emergency Services
City of Capitola, Santa Cruz County

Attachment: Grand Avenue Pathway - PC Staff Report - 02.06.2020 (Grand Avenue Pathway Improvements)

CITY OF CAPITOLA
PROFESSIONAL SERVICES AGREEMENT
 Emergency Storm Drain Installation on Hollister Avenue
 Anderson Pacific Engineering Construction

THIS AGREEMENT is entered into on December 4, 2019, by and between the City of Capitola, a Municipal Corporation, hereinafter called "City" and Anderson Pacific Engineering Construction, Inc., hereinafter called "Contractor".

WHEREAS, City desires certain services described in Appendix One and Contractor is capable of providing and desires to provide these services;

NOW, THEREFORE, City and Contractor for the consideration and upon the terms and conditions hereinafter specified agree as follows:

SECTION 1
Scope of Services

The services to be performed under this Agreement are for emergency construction of a new drain inlet and out fall pipe at the end of Hollister Drive on Depot Hill and further detailed in Appendix One.

SECTION 2
Duties of Contractor

All work performed by Contractor, or under its direction, shall be sufficient to satisfy the City's objectives for entering into this Agreement and shall be rendered in accordance with the generally accepted practices, and to the standards of, Contractor's profession.

Contractor shall not undertake any work beyond the scope of work set forth in Appendix One unless such additional work is approved in advance and in writing by City. The cost of such additional work shall be reimbursed to Contractor by City on the same basis as provided for in Section 4.

If, in the prosecution of the work, it is necessary to conduct field operations, security and safety of the job site will be the Contractor's responsibility excluding, nevertheless, the security and safety of any facility of City within the job site which is not under the Contractor's control.

Contractor shall meet with Steven Jesberg, called "Director," or other City personnel, or third parties as necessary, on all matters connected with carrying out of Contractor's services described in Appendix One. Such meetings shall be held at the request of either party hereto. Review and City approval of completed work shall be obtained monthly, or at such intervals as may be mutually agreed upon, during the course of this work.

SECTION 3
Duties of the City

City shall make available to Contractor all data and information in the City's possession which City deems necessary to the preparation and execution of the work, and City shall actively aid and assist Contractor in obtaining such information from other agencies and individuals as necessary.

The Director may authorize a staff person to serve as his or her representative for conferring with Contractor relative to Contractor's services. The work in progress hereunder shall be reviewed from time to time by City at the discretion of City or upon the request of Contractor. If the work is satisfactory, it will be approved. If the work is not satisfactory, City will inform Contractor of the changes or revisions necessary to secure approval.

SECTION 4 Fees and Payment

Payment for the Contractor's services shall be made upon a schedule and within the limit, or limits shown, upon Appendix Two. Such payment shall be considered the full compensation for all personnel, materials, supplies, and equipment used by Contractor in carrying out the work. If Contractor is compensated on an hourly basis, Contractor shall track the number of hours Contractor, and each of Contractor's employees, has worked under this Agreement during each fiscal year (July 1 through June 30) and Contractor shall immediately notify City if the number of hours worked during any fiscal year by any of Contractor's employees reaches 900 hours. In addition, each invoice submitted by Contractor to City shall specify the number of hours to date Contractor, and each of Contractor's employees, has worked under this Agreement during the current fiscal year.

SECTION 5 Changes in Work

City may order major changes in scope or character of the work, either decreasing or increasing the scope of Contractor's services. No changes in the Scope of Work as described in Appendix One shall be made without the City's written approval. Any change requiring compensation in excess of the sum specified in Appendix Two shall be approved in advance in writing by the City.

SECTION 6 Time of Beginning and Schedule for Completion

This Agreement will become effective on December 4, 2019 and will terminate on the earlier of:

- The date Contractor completes the services required by this Agreement, as agreed by the City; or
- The date either party terminates the Agreement as provided below.

Work shall begin on or about December 4, 2019.

In the event that major changes are ordered or Contractor is delayed in performance of its services by circumstances beyond its control, the City will grant Contractor a reasonable adjustment in the schedule for completion provided that to do so would not frustrate the City's objective for entering into this Agreement. Contractor must submit all claims for adjustments to City within thirty calendar days of the time of occurrence of circumstances necessitating the adjustment.

SECTION 7 Termination

City shall have the right to terminate this Agreement at any time upon giving ten days written notice to Contractor. Contractor may terminate this Agreement upon written notice to City should the City fail to fulfill its duties as set forth in this Agreement. In the event of termination, City shall pay the Contractor for all services performed and accepted under this Agreement up to the date of termination.

SECTION 8

Insurance

Contractor shall procure and maintain for the duration of the contract and for 2 years thereafter, insurance against claims for injuries to persons or damages to property which may arise from or in connection with the performance of the work hereunder by the Contractor, his agents, representatives, or employees.

Minimum Scope of Insurance

Coverage shall be at least as broad as:

1. Insurance Services Office Commercial General Liability coverage (Occurrence Form CG 0001).
2. Insurance Services office Form Number CA 0001 covering Automobile Liability, Code 1 (any auto).
3. Workers' Compensation insurance as required by the State of California, and Employer's Liability Insurance.

Minimum Limits of Insurance

Contractor shall maintain limits no less than:

- | | | |
|----|---|--|
| 1. | General Liability:
(including operations, products and completed operations) | \$1,000,000 per occurrence and \$2,000,000 in aggregate (including operations, for bodily injury, personal and property damage). |
| 2. | Automobile Liability: | \$1,000,000 per accident for bodily injury and property damage. |
| 3. | Employer's Liability Insurance | \$1,000,000 per accident for bodily injury and property damage. |
| 4. | .Blank | |

Other Insurance Provisions

The commercial general liability and automobile liability policies are to contain, or be endorsed to contain, the following provisions:

Professional Services Agreement December 4, 2019
 Emergency Storm Drain Construction on Hollister Avenue
 Anderson Pacific Engineering Contractors, Inc
 Page 4

1. The City of Capitola, its officers, officials, employees and volunteers are to be covered as additional insured's as respects: liability arising out of work or operations performed by or on behalf of the Contractor or automobiles owned, leased, hired or borrowed by the Contractor.
2. For any claims related to this project, the Contractor's insurance coverage shall be primary insurance as respects the City, its officers, officials, employees and volunteers. Any insurance or self-insurance maintained by the City, its officers, officials, employees or volunteers shall be excess of the Contractor's insurance and shall not contribute with it.
3. Each insurance policy required by this clause shall be endorsed to state that coverage shall not be canceled except after prior written notice has been given to the City.

Acceptability of Insurers

Insurance is to be placed with insurers with a current A.M. Best's rating of no less than A:VII, unless otherwise acceptable to the City.

Waiver of Subrogation

Contractor hereby agrees to waive rights of subrogation which any insurer of Contractor may acquire from Contractor by virtue of the payment of any loss. Contractor agrees to obtain any endorsement that may be necessary to affect this waiver of subrogation. **The Workers' Compensation policy shall be endorsed with a waiver of subrogation in favor of the City of Capitola** for all work performed by the Contractor, its employees, agents and subcontractors.

Verification of Coverage

Contractor shall furnish the City with original certificates and amendatory endorsements affecting coverage by this clause. The endorsements should be on forms provided by the City or on other than the City's forms provided those endorsements conform to City requirements. All certificates and endorsements are to be received and approved by the City before work commences. The City reserves the right to require complete, certified copies of all required insurance policies, including endorsements affecting the coverage required by these specifications at any time.

SECTION 9 Indemnification

For General Services: To the fullest extent permitted by law, Contractor agrees to indemnify, defend, and hold harmless the City, its directors, officers, employees from and against any and all claims, demands, actions, liabilities, damages, judgments, or expenses (including attorneys' fees and costs) arising from the acts or omissions of Contractor's employees or agents in any way related to the obligations or in the performance of services under this Agreement, except for design professional services as defined in Civil Code § 2782.8, and except where caused by the sole or active negligence, or willful misconduct of the City.

For Design Professional Services under Civil Code §2782.8: To the fullest extent permitted by law, Contractor agrees to indemnify, defend, and hold harmless the City, its directors, officers, and employees from and against any and all claims, demands, actions, liabilities, damages, or expenses (including attorneys' fees and costs) arising from the negligence, recklessness, or willful misconduct of the Contractor, Contractor's employees, or agents in any way related to the obligations or in the performance of design professional services under this Agreement as defined in Civil Code §2782.8, except where caused by the sole or active negligence, or willful misconduct of the City. The costs to defend charged to the Contractor

Professional Services Agreement December 4, 2019
 Emergency Storm Drain Construction on Hollister Avenue
 Anderson Pacific Engineering Contractors, Inc
 Page 5

relating to design professional services shall not exceed the Contractor's proportionate percentage of fault per Civil Code §2782.8. and against all claims, damages, losses, and expenses including attorney fees arising out of the performance of the work described herein, caused in whole or in part by any negligent act or omission of the Contractor, Contractor's employees, agents or subcontractors, except where caused by the active negligence, sole negligence, or willful misconduct of the City.

SECTION 10 Civil Rights Compliance/Equal Opportunity Assurance

Every supplier of materials and services and all contractors doing business with the City of Capitola shall be in compliance with the applicable provisions of the Americans with Disabilities Act of 1990, and shall be an equal opportunity employer as defined by Title VII of the Civil Rights Act of 1964 and including the California Fair Employment and Housing Act of 1980. As such, contractor shall not discriminate against any person on the basis of race, religious creed, color, national origin, ancestry, disability, medical condition, marital status, age or sex with respect to hiring, application for employment, tenure or terms and conditions of employment. Contractor agrees to abide by all of the foregoing statutes and regulations.

SECTION 11 Legal Action/Attorneys' Fees

If any action at law or in equity is brought to enforce or interpret the provisions of this Agreement, the prevailing party shall be entitled to reasonable attorney's fees in addition to any other relief to which he or she may be entitled. The laws of the State of California shall govern all matters relating to the validity, interpretation, and effect of this Agreement and any authorized or alleged changes, the performance of any of its terms, as well as the rights and obligations of Contractor and the City.

SECTION 12 Assignment

This Agreement shall not be assigned without first obtaining the express written consent of the Director after approval of the City Council.

SECTION 13 Amendments

This Agreement may not be amended in any respect except by way of a written instrument which expressly references and identifies this particular Agreement, which expressly states that its purpose is to amend this particular Agreement, and which is duly executed by the City and Contractor. Contractor acknowledges that no such amendment shall be effective until approved and authorized by the City Council, or an officer of the City when the City Council may from time to time empower an officer of the City to approve and authorize such amendments. No representative of the City is authorized to obligate the City to pay the cost or value of services beyond the scope of services set forth in Appendix Two. Such authority is retained solely by the City Council. Unless expressly authorized by the City Council, Contractor's compensation shall be limited to that set forth in Appendix Two.

SECTION 14 Miscellaneous Provisions

1. *Project Manager.* Director reserves the right to approve the project manager assigned by Contractor to said work. No change in assignment may occur without prior written approval of the City.

Professional Services Agreement December 4, 2019
Emergency Storm Drain Construction on Hollister Avenue
Anderson Pacific Engineering Contractors, Inc
Page 6

2. *Contractor Service.* Contractor is employed to render professional services only and any payments made to Contractor are compensation solely for such professional services.

3. *Licensure.* Contractor warrants that he or she has complied with any and all applicable governmental licensing requirements.

4. *Other Agreements.* This Agreement supersedes any and all other agreements, either oral or in writing, between the parties hereto with respect to the subject matter, and no other agreement, statement or promise related to the subject matter of this Agreement which is not contained in this Agreement shall be valid or binding.

5. *City Property.* Upon payment for the work performed, or portion thereof, all drawings, specifications, records, or other documents generated by Contractor pursuant to this Agreement are, and shall remain, the property of the City whether the project for which they are made is executed or not. The Contractor shall be permitted to retain copies, including reproducible copies, of drawings and specifications for information and reference in connection with the City's use and/or occupancy of the project. The drawings, specifications, records, documents, and Contractor's other work product shall not be used by the Contractor on other projects, except by agreement in writing and with appropriate compensation to the City.

6. *Contractor's Records.* Contractor shall maintain accurate accounting records and other written documentation pertaining to the costs incurred for this project. Such records and documentation shall be kept available at Contractor's office during the period of this Agreement, and after the term of this Agreement for a period of three years from the date of the final City payment for Contractor's services.

7. *Independent Contractor.* In the performance of its work, it is expressly understood that Contractor, including Contractor's agents, servants, employees, and subcontractors, is an independent contractor solely responsible for its acts and omissions, and Contractor shall not be considered an employee of the City for any purpose.

8. *Conflicts of Interest.* Contractor stipulates that corporately or individually, its firm, its employees and subcontractors have no financial interest in either the success or failure of any project which is, or may be, dependent on the results of the Contractor's work product prepared pursuant to this Agreement.

9. *Notices.* All notices herein provided to be given, or which may be given by either party to the other, shall be deemed to have been fully given and fully received when made in writing and deposited in the United States mail, certified and postage prepaid, and addressed to the respective parties as follows:

Professional Services Agreement December 4, 2019
Emergency Storm Drain Construction on Hollister Avenue
Anderson Pacific Engineering Contractors, Inc
Page 7

CITY
CITY OF CAPITOLA
420 Capitola Avenue
Capitola, CA 95010
831-475-7300

CONTRACTOR
Anderson Pacific Engineering Construction
1390 Norman Avenue
Santa Clara, CA 95054-2047
408-970-9900

By: 
Benjamin Goldstein, City Manager

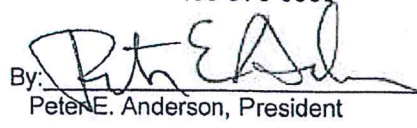
By: 
Peter E. Anderson, President

Dated: 12/6/19

Dated: 12/4/19

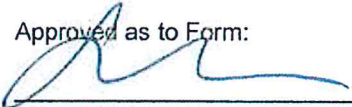
Approved as to Form:

Samantha Zutler, City Attorney

Attachment: Grand Avenue Pathway - PC Staff Report - 02.06.2020 (Grand Avenue Pathway Improvements)

Professional Services Agreement December 4, 2019
Emergency Storm Drain Construction on Hollister Avenue
Anderson Pacific Engineering Contractors, Inc
Page 8

APPENDIX ONE Scope of Services

Due to bluff failure along Grand Avenue on Depot Hill, the drainage from Hollister Avenue is now flowing directly onto the failed and exposed slope. The City has directed the installation of a new drain inlet at the end of Hollister Avenue, above the bluff, to capture the runoff and direct it over the bluff. The outfall shall be built in conformance with the plans provided by the City titled Cross Sections Showing Bluff Top Drain Lines by Haro Kasunich and Associates Inc. dated January 28, 2010.

Contractor shall coordinate all work with Department of Public Works personnel to insure inspections of the work are completed. It is anticipated that decisions and directions to the final layout and construction will be made by City and Contractor personnel in the field.

Time is of the essence in completing this work and the contractor shall diligently work to complete this project as quickly as possible.

APPENDIX TWO Fees and Payments

For the services performed, City will pay contractor on a force account basis for time, materials, and equipment needed to satisfactory complete the services and delivery of work products. Payments will be issued monthly as charges accrue, the sum of contractor's salary expenses and non-salary expenses. For work that is performed payments under this contract the Contractor will be made per the markups specified in the attached Daily Extra Work Report (DEWR).

Contractor hereby represents and warrants, based upon Contractor's independent determination of the time and labor, including overtime, which will be required to perform said services, that Contractor will provide all said services. Contractor shall provide daily reports on labor, materials, and equipment used on the job site for verification by the City.

Salary expenses include the actual direct pay of personnel assigned to the project (except for routine secretarial and account services) plus payroll taxes, insurance, sick leave, holidays, vacation, and other fringe benefits. The percentage of compensation attributable to salary expenses includes all of Contractor's indirect overhead costs and fees. For purposes of this Agreement, Contractor's salary expenses and non-salary expenses will be compensated at the rates set forth in the fee schedule attached to this appendix and in accordance with the terms set forth therein. Non-salary expenses include travel, meals and lodging while traveling, materials other than normal office supplies, reproduction and printing costs, equipment rental, computer services, service of subcontractors or subcontractors, and other identifiable job expenses. The use of Contractor's vehicles for travel shall be paid at the current Internal Revenue Service published mileage rate.

Payments shall be made monthly by the City, based on itemized invoices from the Contractor which list actual costs and expenses. Such payments shall be for the invoice amount. The monthly statements shall contain the following affidavit signed by a principal of the Contractor's firm:

"I hereby certify as principal of the firm of _____, that the charge of \$_____ as summarized above and shown in detail on the attachments is fair and reasonable, is in accordance with the terms of the Agreement dated _____, __, and has not been previously paid."

Hollister Avenue Storm Drain Emergency Construction



April 17, 2017 drone photo of Grand Avenue pathway at time of closure due to risk of further slope failure



December 4, 2019 drone photo of slope failure along Grand Avenue pathway. Oakland Avenue to the left of photo.

Attachment: Grand Avenue Pathway - PC Staff Report - 02.06.2020 (Grand Avenue Pathway Improvements)

Hollister Avenue Storm Drain Emergency Construction

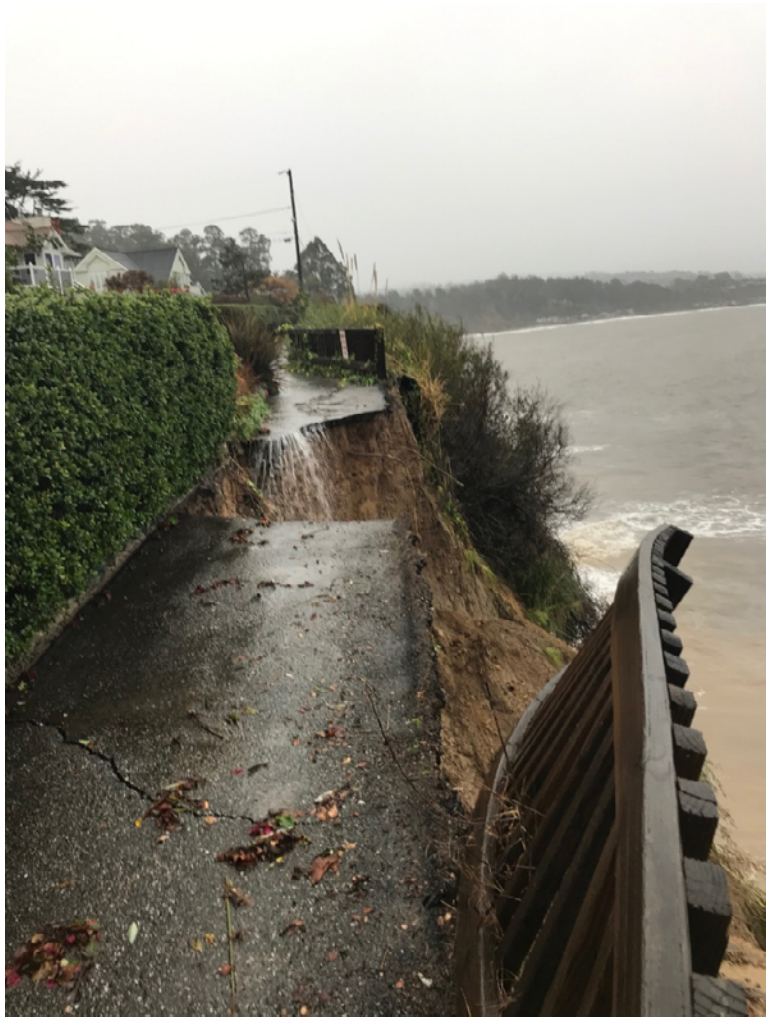

Runoff draining into area of slope failure



Overhead view showing cavity created by storm runoff

Hollister Avenue Storm Drain Emergency Construction



New drainage inlet at the end of Hollister Avenue constructed under emergency declaration

Hollister Avenue Storm Drain Emergency Construction



Plastic sheeting installed by neighboring property owner

CALIFORNIA COASTAL COMMISSION

CENTRAL COAST DISTRICT OFFICE
 725 FRONT STREET, SUITE 300
 SANTA CRUZ, CA 95060
 PHONE: (831) 427-4863
 FAX: (831) 427-4877
 WEB: WWW.COASTAL.CA.GOV



December 16, 2019

City Council
 City of Capitola
 420 Capitola Avenue
 Capitola, CA 95010

Subject: Grand Avenue Pathway Emergency Declaration - Item 10A

Dear Honorable Members of the Capitola City Council:

It is our understanding that the portion of the Grand Avenue pathway that was previously closed under City-issued Coastal Development Permit (CDP) #17-0380 was further undermined following heavy rain, and that emergency action was taken, including the creation of a new drainage inlet and the placement of plastic sheeting. Accordingly, the City should process an emergency CDP as soon as possible for any work that has already been done, and for any additional work still necessary to abate the emergency situation (e.g., removing any fencing, asphalt, etc.; installation of drainage components and plastic sheeting on the bluff area). We would like to encourage the City to remove any non-plant materials from the top of the bluff and along the bluff (e.g.: asphalt, plastic, sand bags, and fencing) to prevent these materials from falling onto the beach area and ultimately into the ocean. In terms of the required follow-up CDP to authorize the work done under the Emergency CDP, we would encourage the City to: 1) examine what level of storm (i.e., the 10-year storm, 20-year storm, etc.) that the existing drainage inlets can accommodate; 2) consider additional drainage improvements to prevent runoff down the bluff, as well as explore other measures that may be suitable to prevent/reduce erosion in this area; and 3) examine the feasibility of reclaiming the public right-of-way to allow for a through public pathway, even if such a path could only exist for a relatively short planning horizon (e.g., 5-20 years) and is a more informal pathway (e.g. compacted dirt, decomposed granite, etc. as opposed to concrete or asphalt). We see the follow-up CDP process as an opportunity to seek solutions that both address coastal bluff erosion as well as restore lateral public coastal access along the bluff.

In terms of longer term solutions and planning, it is our understanding that the City received a grant to complete a formal hazards assessment and will be undertaking a Local Coastal Program (LCP) update to appropriately plan for coastal hazards and sea level rise. We are interested in coordinating with City planning and public works staff (who are copied on this letter), including to better understand what the City has learned thus far from the hazards assessment, and to assist the City in its upcoming LCP update process. Please let us know how we can best assist with this process at your convenience.

Attachment: Grand Avenue Pathway - PC Staff Report - 02-06-2020 (Grand Avenue Pathway Improvements)

City Council
Grand Avenue Pathway Emergency Declaration - Item 10A
December 16, 2019
Page 2

Thank you for your consideration.

Sincerely,

Rainey Graeven

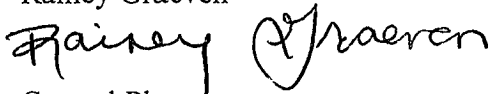

Coastal Planner
Central Coast District Office

cc: Katie Herlihy, Community Development Director
Steve Jesberg, Public Works Director

SECTION A-A' (Central Avenue)

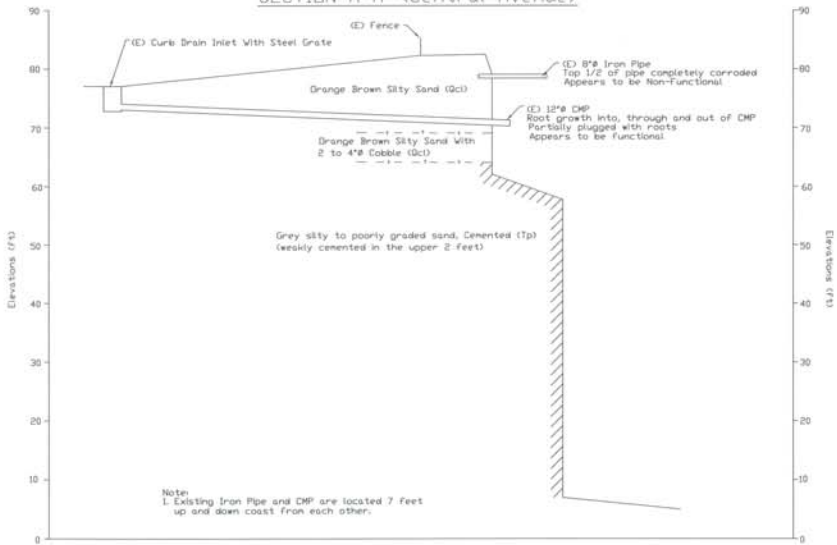

SECTION C-C' (Sacramento Avenue)

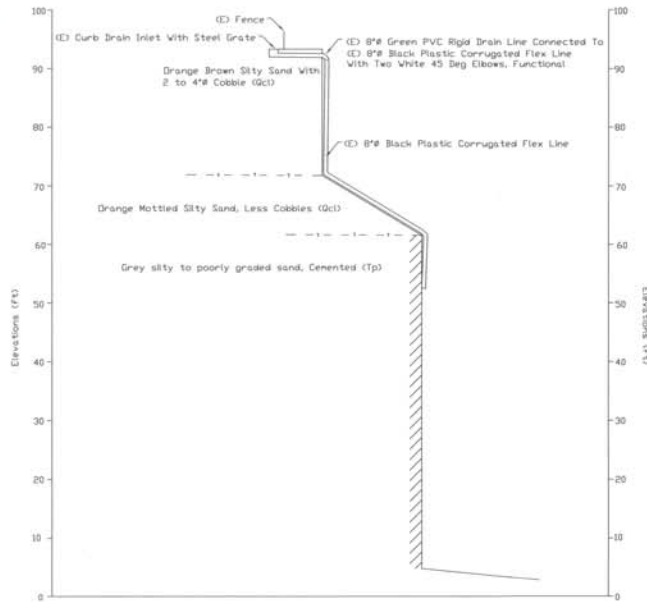

SECTION B-B' (Between Saxon & Oakland Avenue)

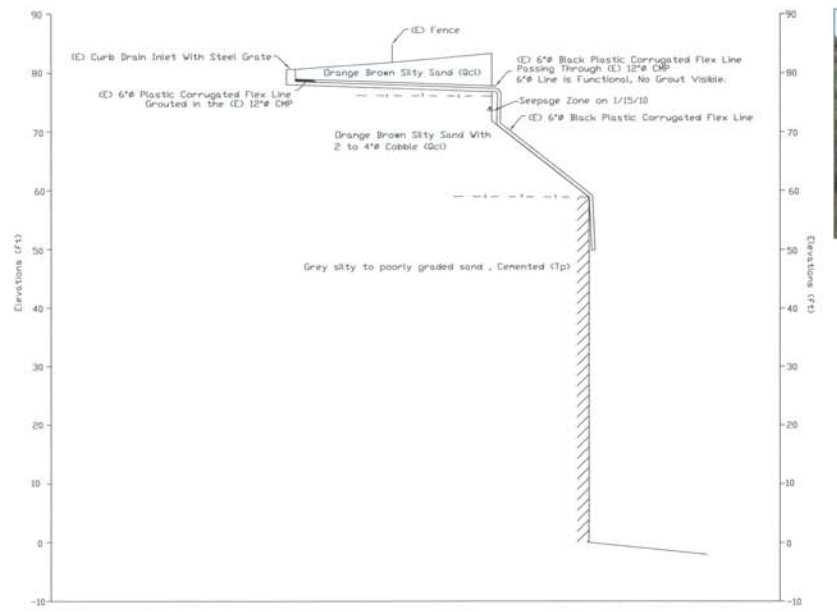

PROPOSED TEMPORARY DRAIN LINE REPAIR AT SECTION A-A' (Central Avenue)

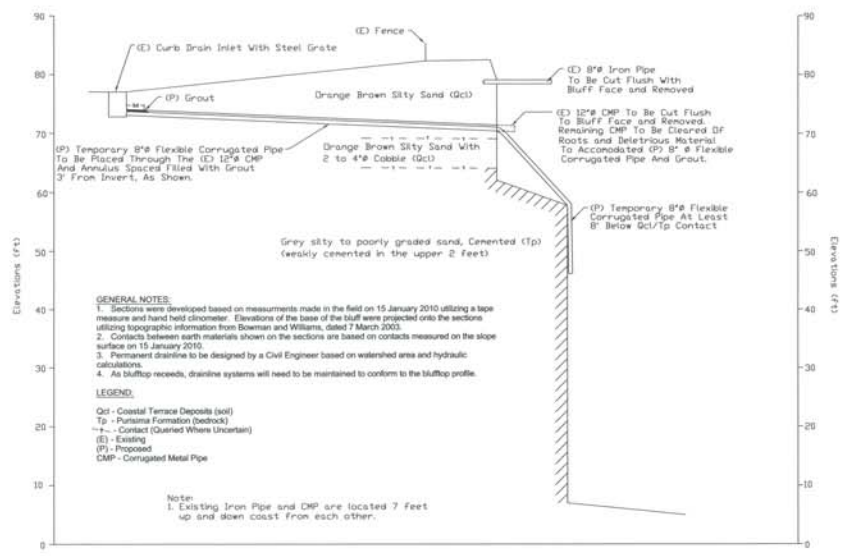

REVISED DATE:	BY:
March 2010	WKA

HARO KASUNICH AND ASSOCIATES, INC.
 GEOTECHNICAL AND COASTAL ENGINEERING
 116 EAST LAKE AVENUE, WATSONVILLE, CA 95076
 PH: (831) 722-4175 FAX: (831) 722-3202

CROSS SECTIONS SHOWING BLUFF TOP DRAIN LINES
 DEPOT HILL GRAD
 BETWEEN CENTRAL AND SACRAMENTO AVENUE
 CAPITOLA, CALIFORNIA

JOB NO:	SC6840.2
DATE:	1/28/10
BY:	BILL S.
SCALE:	1"=10' (V-H)
SHEET:	1

Attachment: Grand Avenue Pathway - PC Staff Report - 02.06.2020 (Grand Avenue Pathway)

Grand Avenue Emergency Drainage Construction

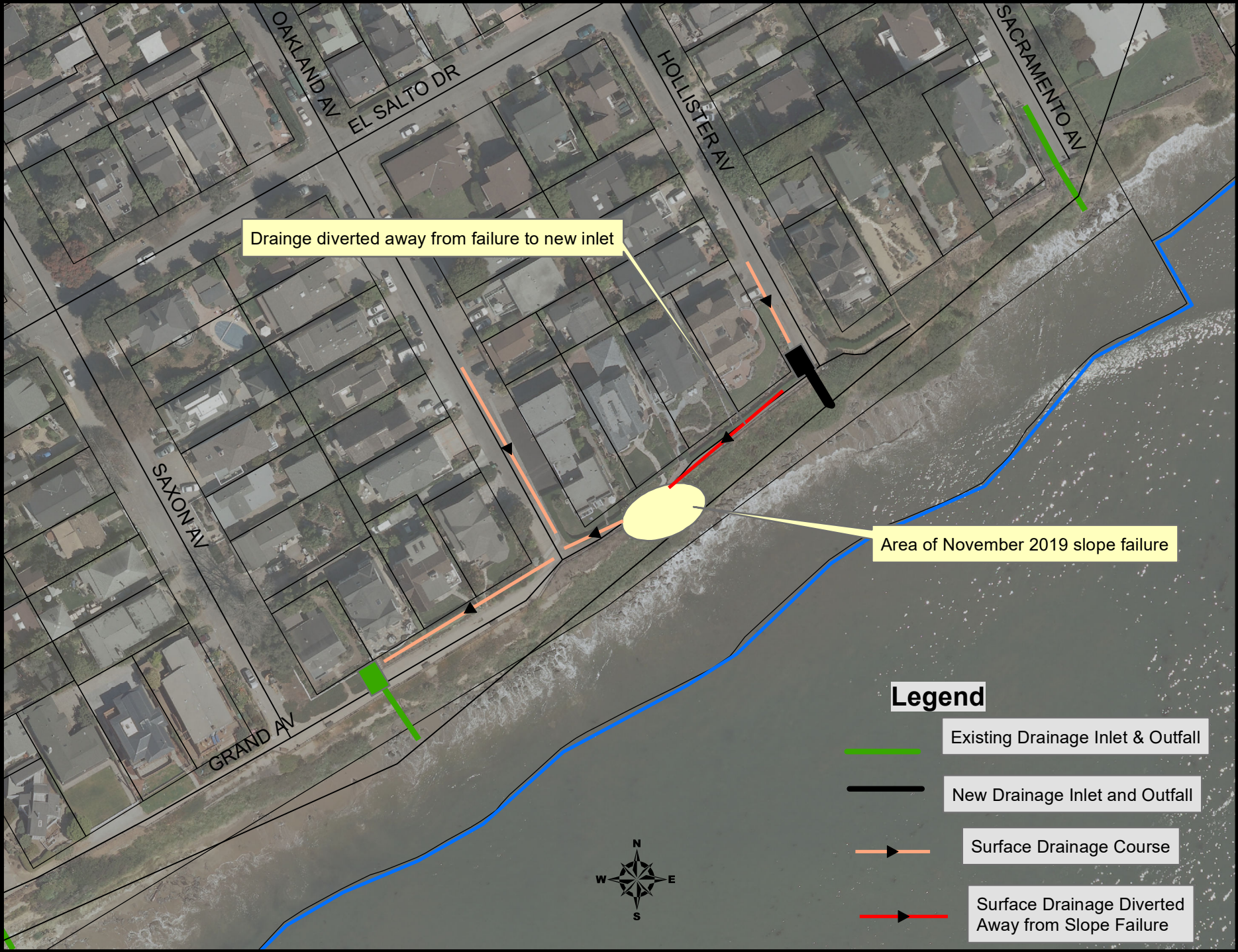

Drainage diverted away from failure to new inlet

Area of November 2019 slope failure

Legend

- Existing Drainage Inlet & Outfall
- New Drainage Inlet and Outfall
- Surface Drainage Course
- Surface Drainage Diverted Away from Slope Failure

1 inch = 100 feet

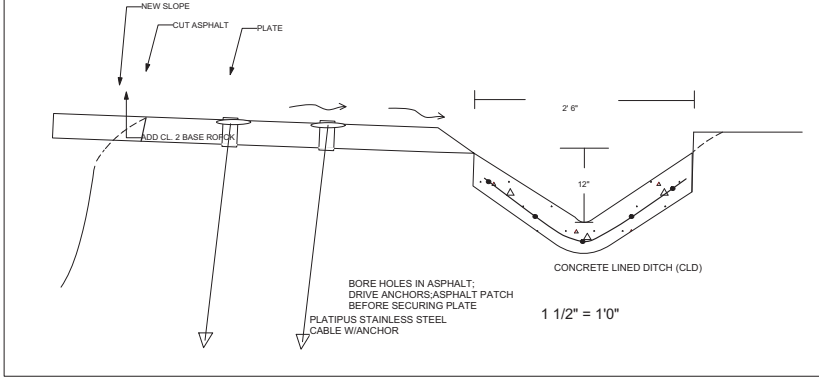
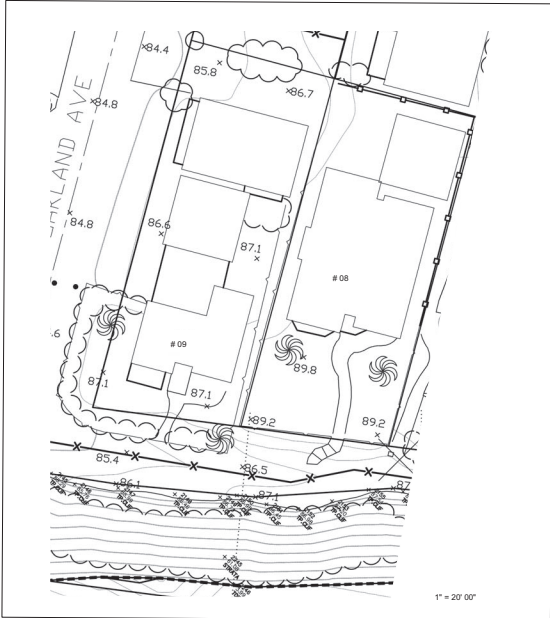

DRAINAGE AND EROSION CONTROL

- NOTES:**
- SURFACE WATER FLOW
 - EXISTING ELEVATIONS
 - R-45 TURF REINFORCEMENT MATTING (TRM) PLATIPUS ANCHORS + PINS HYDROSEED MIXTURE

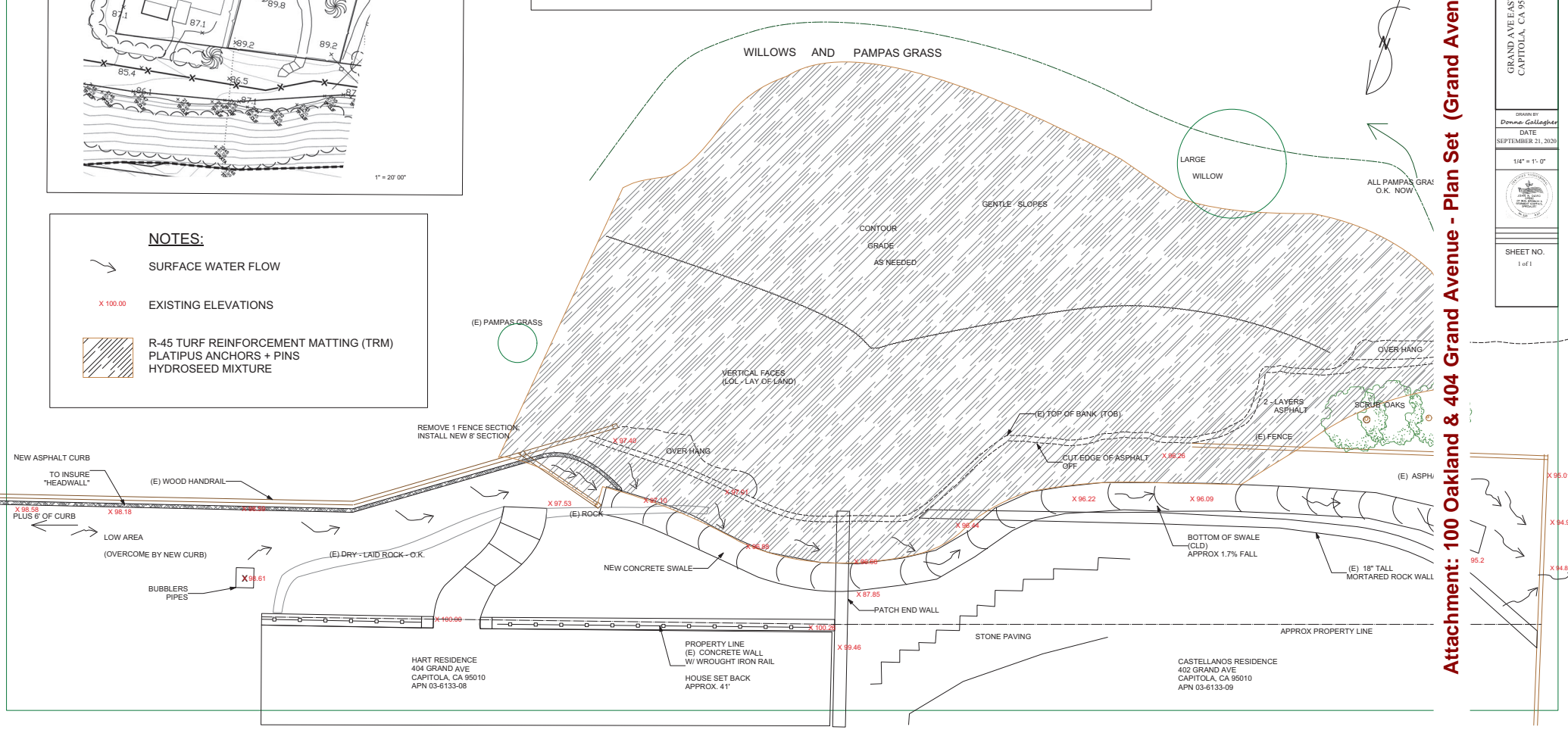

REVISIONS

DESIGNED BY: Donna Gallagher
 DATE: SEPTEMBER 21, 2020
 SCALE: 1/4" = 1'-0"
 SHEET NO. 1 of 1



GRAND AVE EAST
 CAPITOLA, CA 95010



SHEET NO.
 1 of 1

Attachment: 100 Oakland & 404 Grand Avenue - Plan Set (Grand Avenue Pathway Improvements)



September 21, 2020

Grand Avenue East -Depot Hill
 Attn: Jim Castellanos and John Hart – 402 and 404 Grand.Ave.
 Capitola, CA 95010

Water Diversion and Slope Stabilization Proposal

Demolition:

- Remove 9 l.f. existing wooden handrails including 1 ea. 4" x 6" post; haul
- Cut and haul from slope: 1 ea. 2" metal pipe, 1" galvanized pipe, ¾" gas line
- Cut and haul 3" sewer pipe from bottom of cliff
- Remove existing tarps, sandbags, and other misc. debris from slope; haul
- Remove fallen wooden fence on the side of slope; haul
- Sawcut and remove 90 l.f. asphalt (narrow strip) along cliff edge and 121 sq. ft. asphalt for new concrete ditch; haul
- Sawcut and remove 7 ½ l.f. of existing 15" thick concrete retaining wall with wrought iron fence (between Hart and Castellano properties); haul; stucco wall end and repair wall cap; complete altered wrought iron fencing
- Remove 15 l.f. of existing 18" tall mortared stone retaining wall (Castellano property); haul
- Remove 12 l.f. of existing 12" tall dry stacked stone retaining wall (Hart property); stockpile on site
- Prune smaller 2 ea. existing scrub oaks; haul
- Remove other light vegetation from top of bank; haul
- Remove approx. 16 l.f. of shrub hedge along existing mortared stone wall (Castellano property)
- Remove existing Bougainvillea, Escallonia, roses, and other misc. vegetation, as needed
- Remove excess soil from 126 sq. ft. planter beds adjacent to concrete ditch; haul

Water Diversion:

- Construct temporary fencing on both ends of work area to keep out pedestrians
- Hand excavate trench 83 l.f. x 2 ½' wide x 1 1/4' deep (average) for concrete lined ditch; haul
- Grade to ensure 1.7% fall and compact subgrade
- Install forms for the concrete lined ditch
- Install 585 l.f. 3/8" rebar
- Pour approx. 5 cu. yds. of 3000 psi concrete as a 83 l.f. concrete lined ditch; bottom of ditch starting at 12" below grade and ending at grade
- Patch edges of newly installed concrete lined ditch with asphalt
- Cut ivy and willow along 38 l.f. of existing wooden handrail; haul
- Install 38 l.f. asphalt curb 6" tall x 8" wide along existing wooden handrail to control water from asphalt walkway into the new concrete lined ditch and to ensure water does not flow over the bank
- Test new system to ensure proper drainage

September 21, 2020
 Grand Ave. East
 Page 2 of 2

Slope Stabilization:

- Grade and compact new top of bank for best stable contours; ensure water drains back towards the new concrete lined ditch and not over the bank
- Install and compact CI 2 baserock along new asphalt edge and top of bank for softer edge
- Hand grade and compact approx. 980 sq. ft. of vertical sloping face as needed for best stable contours
- Hand grade and compact approx. 1142 sq. ft. of lower gentler slope as needed for best stable contours
- Core 90 ea. (2 rows of 45) 2" wide bore holes 2' on center in asphalt on the top of bank
- Install approx. 2472 sq. ft. Profile Futerra R-45 HP turf reinforcement matting (TRM) on upper plateau and vertical and more gentle slopes; first secured with 18" and 12" pins, then anchored with 286 ea. Platipus 3' stainless steel cable earth anchors (patch holes with asphalt after driving anchors in, before securing anchors with steel plates)
- Hydroseed over R-45 with a 2-step application:
 (1st application: soil builder, seeds, fertilizer; 2nd application: fiber mulch)
 - 212 lbs. Proganics Biotic Soil Media (soil builder)
 - 53 lbs. Biosol 7-2-1 organic fertilizer
 - 6.5 lbs. 6-seed native grass blend
 - 11 lbs. whole barley erosion grass seed
 - 106 lbs. Promatrix Engineered Fiber Matrix wood mulch

Other:

- Install 1 ea. 4" x 4" pressure treated D. fir as new fence post; complete 8 l.f. matching handrail
- Re-set stockpiled dry stack stone retaining wall (Hart property)
- Apply new mulch to disturbed planter beds (both properties)
- Construct permanent barrier fence to keep pedestrians out

Grand Avenue East:
 Gene Bernald 406 Grand Ave. Capitola, CA 95010

Water Diversion Proposal

Work to include:

- Remove ivy, willow, and other miscellaneous vegetation along 46 l.f. of existing wooden fence
- Install 46 l.f. asphalt curb 6" tall x 8" wide along existing wooden handrail to divert water from asphalt walkway toward the new concrete lined ditch and to ensure water does not flow over the bank
- Test new system to ensure proper drainage

DESIGN/BUILD LANDSCAPE & EROSION CONTROL LANDSCAPE MAINTENANCE
 CA Lic. #399064 Certified Soil & Sediment Control Specialist #523 Member: California Landscape Contractors Association
FINE GARDENS FOR TODAY AND TOMORROW

www.primelandscape.com