

# City of Capitola Agenda

Mayor: Stephanie Harlan  
Vice Mayor: Sam Storey  
Council Members: Ed Bottorff  
Dennis Norton  
Michael Termini  
Treasurer: Kym DeWitt



## CAPITOLA CITY COUNCIL REGULAR MEETING

THURSDAY, MAY 23, 2013

CITY HALL COUNCIL CHAMBERS  
420 CAPITOLA AVENUE, CAPITOLA, CA 95010

### CLOSED SESSION – 5:45 PM CITY MANAGER’S OFFICE

*An announcement regarding the items to be discussed in Closed Session will be made in the City Hall Council Chambers prior to the Closed Session. Members of the public may, at this time, address the City Council on closed session items only. There will be a report of any final decisions in City Council Chambers during the City Council's Open Session Meeting.*

#### **CONFERENCE WITH LEGAL COUNSEL – EXISTING LITIGATION (Govt. Code §54956.9)**

Schroedel et al. v. the City of Capitola, the Santa Cruz Superior Court Case No. CV 175684

#### **CONFERENCE WITH LEGAL COUNSEL – ANTICIPATED OF LITIGATION**

**[Significant exposure to litigation pursuant to subdivision (b) of Govt. Code §54956.9]**

Surf and Sand Mobile Home Park

#### **CONFERENCE WITH LABOR NEGOTIATOR (Govt. Code §54957.6)**

Negotiator: Lisa Murphy, Administrative Services Director

Employee Organizations:

Capitola Police Officers Association; Capitola Police Captains; Association of Capitola Employees; Confidential Employees; Mid-Management Group; Department Head Group; and City Manager

#### **PUBLIC EMPLOYEE PERFORMANCE EVALUATION (Govt. Code § 54957)**

City Council's Performance Evaluation of the City Attorney

#### **LIABILITY CLAIMS (Govt. Code §54956.95)**

Claimant: Dominique Townsend

Agency claimed against: City of Capitola

**REGULAR MEETING OF THE CAPITOLA CITY COUNCIL – 7:00 PM**

*All matters listed on the Regular Meeting of the Capitola City Council Agenda shall be considered as Public Hearings.*

**1. ROLL CALL AND PLEDGE OF ALLEGIANCE**

Council Members Dennis Norton, Sam Storey, Ed Bottorff, Michael Termini and Mayor Stephanie Harlan

**2. PRESENTATIONS**

A. Proclamation designating the Month of May 2013 “Clean Air Month.”

B. Proclamation designating May 18th through May 24th “National Safe Boating Week.”

**3. REPORT ON CLOSED SESSION**

**4. ADDITIONS AND DELETIONS TO AGENDA**

**5. PUBLIC COMMENTS**

*Oral Communications allows time for members of the Public to address the City Council on any item not on the Agenda. Presentations will be limited to three minutes per speaker. Individuals may not speak more than once during Oral Communications. All speakers must address the entire legislative body and will not be permitted to engage in dialogue. All speakers are requested to print their name on the sign-in sheet located at the podium so that their name may be accurately recorded in the minutes. A MAXIMUM of 30 MINUTES is set aside for Oral Communications at this time.*

**6. COUNCIL/STAFF ANNOUNCEMENTS**

**7. BOARDS, COMMISSIONS AND COMMITTEES APPOINTMENTS**

**8. CONSENT CALENDAR**

*All items listed in the “Consent Calendar” will be enacted by one motion in the form listed below. There will be no separate discussion on these items prior to the time the Council votes on the action unless members of the public or the City Council request specific items to be discussed for separate review. Items pulled for separate discussion will be considered following General Government.*

*Note that all Ordinances which appear on the public agenda shall be determined to have been read by title and further reading waived.*

A. Consider approving the City Council Minutes of the Regular Meeting May 9, 2013.

RECOMMENDED ACTION:

Approve Minutes.

B. Approval of City Check Register Reports dated April 19, 2013; April 25, 2013; May 3, 2013; and May 10, 2013.

RECOMMENDED ACTION:

Approve the City Check Register Reports.

C. Confirmation of the City’s Investment Policy, Administrative Policy Number III-1.

RECOMMENDED ACTION:

Confirm Investment Policy.

## CAPITOLA CITY COUNCIL - May 23, 2013

- D. Consider approving the third amendment to the Agreement for City Attorney Services with Atchison, Barisone, Condotti & Kovacevich in the amount of \$133,560; authorize the City Manager to execute the agreement.  
RECOMMENDED ACTION:  
Approve Agreement.
- E. Deny liability claim of Dominique Townsend in the amount of \$172.17 and forward to the City's liability insurance carrier.  
RECOMMENDED ACTION:  
Deny Liability Claim.
- F. Consider a Resolution approving the City of Capitola Local Hazard Mitigation Plan.  
RECOMMENDED ACTION:  
Adopt Resolution.

### 9. GENERAL GOVERNMENT/PUBLIC HEARINGS

*General Government items are intended to provide an opportunity for public discussion of each item listed. The following procedure is followed for each General Government item: 1) Staff explanation; 2) Council questions; 3) Public comment; 4) Council deliberation; 5) Decision.*

- A. Consider approving the Esplanade Kiosk Public Art Project; approving an agreement with Kim Chavez in an amount not to exceed \$15,000; and approving an Administrative Policy V-12, Use of Display Cases on the Village Esplanade Kiosk.  
RECOMMENDED ACTION:  
1) Approve the proposed Esplanade Kiosk Public Art Project; 2) authorize the City Manager to enter into an agreement with Kim Chavez; and 3) approve Administrative Policy.
- B. Consider authorizing the sale of a portion City-owned property located at McGregor Drive (APN 036-341-02) to the Soquel Creek Water District.  
RECOMMENDED ACTION:  
Approve sale.
- C. Consider a Resolution granting consent to Santa Cruz County to form a second Tourism Marketing District.  
RECOMMENDED ACTION:  
Adopt Resolution.
- D. Consider a framework for review of the Parking Meter Programs.  
RECOMMENDED ACTION:  
Discuss and provide direction.
- E. Consider sending a letter in opposition of Assembly Bill 5, Ammiano "Homeless Bill of Rights".  
RECOMMENDED ACTION:  
Authorize Mayor to send a letter of opposition.

### 10. COUNCIL/STAFF COMMUNICATIONS

## CAPITOLA CITY COUNCIL - May 23, 2013

### 11. CITY COUNCIL/TREASURER COMMENTS/COMMITTEE REPORTS

*City Council Members/City Treasurer may comment on matters of a general nature or identify issues for staff response or future council consideration. Council Members/Committee Representatives may present oral updates from standing committees at this time.*

### 12. ADJOURNMENT

Adjourn to the Special Budget Study Session of the City Council and the Successor Agency to be held on Thursday, May 30, 2013 at 6:00 PM, in the City Hall Council Chambers, 420 Capitola Avenue, Capitola, California.

**Note:** Any person seeking to challenge a City Council decision made as a result of a proceeding in which, by law, a hearing is required to be given, evidence is required to be taken, and the discretion in the determination of facts is vested in the City Council, shall be required to commence that court action within ninety (90) days following the date on which the decision becomes final as provided in Code of Civil Procedure §1094.6. Please refer to code of Civil Procedure §1094.6 to determine how to calculate when a decision becomes "final." Please be advised that in most instances the decision become "final" upon the City Council's announcement of its decision at the completion of the public hearing. Failure to comply with this 90-day rule will preclude any person from challenging the City Council decision in court.

**Notice regarding City Council:** The Capitola City Council meets on the 2nd and 4th Thursday of each month at 7:00 p.m. (or in no event earlier than 6:00 p.m.), in the City Hall Council Chambers located at 420 Capitola Avenue, Capitola.

**Agenda and Agenda Packet Materials:** The City Council Agenda and the complete agenda packet are available on the Internet at the City's website: [www.ci.capitola.ca.us](http://www.ci.capitola.ca.us). Agendas are also available at the Capitola Post Office located at 826 Bay Avenue, Capitola.

**Agenda Document Review:** The complete agenda packet is available at City Hall and at the Capitola Branch Library, 2005 Wharf Road, Capitola, on the Monday prior to the Thursday meeting. Need more information? Contact the City Clerk's office at 831-475-7300.

**Agenda Materials Distributed after Distribution of the Agenda Packet:** Pursuant to Government Code §54957.5, materials related to an agenda item submitted after distribution of the agenda packet are available for public inspection at the Reception Office at City Hall, 420 Capitola Avenue, Capitola, California, during normal business hours.

**Americans with Disabilities Act:** Disability-related aids or services are available to enable persons with a disability to participate in this meeting consistent with the Federal Americans with Disabilities Act of 1990. Assisted listening devices are available for individuals with hearing impairments at the meeting in the City Council Chambers. Should you require special accommodations to participate in the meeting due to a disability, please contact the City Clerk's office at least 24-hours in advance of the meeting at 831-475-7300. In an effort to accommodate individuals with environmental sensitivities, attendees are requested to refrain from wearing perfumes and other scented products.

**Televised Meetings:** City Council meetings are cablecast "Live" on Charter Communications Cable TV Channel 8 and are recorded to be replayed at 12:00 Noon on the Saturday following the meetings on Community Television of Santa Cruz County (Charter Channel 71 and Comcast Channel 25). Meetings are streamed "Live" on the City's website at [www.ci.capitola.ca.us](http://www.ci.capitola.ca.us) by clicking on the Home Page link "View Capitola Meeting Live On-Line." Archived meetings can be viewed from the website at anytime.



# City of Capitola Mayor's Proclamation

Designating the Month of May 2013  
"Clean Air Month"

*WHEREAS, the month of May is designated as Clean Air Month, designed to raise public awareness about the need for every Californian to work to reduce air pollution; and*

*WHEREAS, Americans across the country and here in Capitola are working hard to help limit the pollutants that cause climate change and reduce their impact on the environment; and*

*WHEREAS, clean air is vital and important to our health, environment, and economy; and*

*WHEREAS, due to longer days and warmer temperatures, the month of May is typically the start of the area's ozone season; and*

*WHEREAS, particulate matter air pollution, especially fine particles, can be inhaled deeply into the lungs and cause serious damage, including asthma attacks, respiratory illness and premature death; and*

*WHEREAS, exposure to diesel exhaust from vehicles and equipment can cause adverse health effects ranging from respiratory irritation to cancer; and*

*WHEREAS, small changes in our daily lives can have a big impact on our environment. We can walk, bike, use public transportation; buy products with less packaging; recycle, reuse paper, plastic, glass, and aluminum. We can choose energy efficient products, turning lights off, unplugging appliances, and cutting back on heating and air conditioning; and*

*WHEREAS, along with the Monterey Bay Unified Air Pollution Control Board, Capitola's commitment to environmental protection and public health results in some of the cleanest air in the nation; and*

*WHEREAS, increased public awareness efforts during the month of May and throughout the year will promote actions by Capitola citizens and businesses that will help keep the air clean.*

*NOW, THEREFORE, BE IT RESOLVED, that the City Council of the City of Capitola recognizes May 2013 as Clean Air Month and encourage all citizens to join in the effort to live and work in ways that will insure cleaner air and better health for our community.*

*Stephanie Harlan*

Signed and sealed this 23<sup>rd</sup> day of May 2013





THIS PAGE INTENTIONALLY LEFT BLANK



# City of Capitola

## Mayor's Proclamation

In Recognition of  
**National Safe Boating Week**  
 May 18 through May 24, 2013

*WHEREAS, Recreational boating is fun and enjoyable, and we are fortunate that we have sufficient resources to accommodate the wide variety of pleasure boating demands. However, our waterways can become crowded at times and be a place of chaos and confusion. While being a marvelous source of recreation, boating, to the unprepared, can be a risky sport. Not knowing or obeying the Navigation Rules or the nautical "Rules of the Road," drinking alcohol or taking drugs while operating a boat, or choosing not to wear your life jacket when doing so is clearly NOT the smart thing to do; and*

*WHEREAS, One particular behavior that can reduce the number of boaters who lose their lives by drowning each year by approximately 80% is the wearing of a life jacket. It is a simple task that has the potential to reduce terrible loss in lives. That is why we must continue to spread the messages of boating safety not only during National Safe Boating Week but also throughout the entire year.*

*WHEREAS, on average, 700 people die each year in boating-related accidents in the U.S.; approximately 70% of these are fatalities caused by drowning; and*

*WHEREAS, in 2012, the members of U.S. Coast Guard Auxiliary Flotilla 6-10 Capitola volunteered 6,413 hours in educating the boating public, and in U.S. Coast Guard mission support; and*

*WHEREAS, a significant number of boaters who lose their lives by drowning each year would be alive today had they worn their life jackets; and*

*WHEREAS, today's life jackets are more comfortable, more attractive, and more wearable than styles of years past and deserve a fresh look by today's boating public; and*

*WHEREAS, Flotilla 6-10 Capitola will continue efforts to educate the boating public by offering boating classes and free vessel examinations, promote safe boating and encourage the wearing of life jackets.*

**NOW, THEREFORE, BE IT RESOLVED** that the City of Capitola does hereby designate the week of May 18th through May 24th, 2013 as National Safe Boating Week, and urges all users of ALL in-land lakes, rivers, the Monterey Bay and Coastal Pacific Ocean areas to safeguard their lives by wearing life jackets when boating, attend a safe boating course, exercise safe boating practices, and adopt the slogan of "WEAR IT."

*Stephanie Harlan*

Signed and sealed this 23<sup>rd</sup> day of May 2013





THIS PAGE INTENTIONALLY LEFT BLANK





# CITY COUNCIL AGENDA REPORT

## MEETING OF MAY 23, 2013

FROM: OFFICE OF THE CITY CLERK

SUBJECT: APPROVAL OF THE CITY COUNCIL MEETING MINUTES OF MAY 9, 2013,  
REGULAR MEETING

---

**RECOMMENDED ACTION:** Approve the subject minutes as submitted.

**DISCUSSION:** Attached for City Council review and approval are the minutes to the subject meeting.

**ATTACHMENTS:**

1. May 9, 2013, Regular City Council Minutes;

Report Prepared By: Susan Sneddon, CMC  
City Clerk

Reviewed and Forwarded  
By City Manager: 

THIS PAGE INTENTIONALLY LEFT BLANK

**CAPITOLA CITY COUNCIL  
REGULAR MEETING ACTION SUMMARY  
THURSDAY, MAY 9, 2013 - 7:00 PM**

**CLOSED SESSION – 6:00 PM  
CITY MANAGER’S OFFICE**

**CALL TO ORDER**

Vice Mayor Storey called the meeting to order at 6:00 p.m. and stated that Mayor Harlan was absent. He announced the items to be discussed in Closed Session, as follows:

**CONFERENCE WITH LEGAL COUNSEL – ANTICIPATED LITIGATION  
[Significant exposure to litigation pursuant to subdivision (b) of Govt. Code §54956.9]**

Surf and Sand Mobile Home Park

**CONFERENCE WITH LABOR NEGOTIATOR (Govt. Code §54957.6)**

Negotiator: Lisa Murphy, Administrative Services Director  
Employee Organizations: Capitola Police Officers Association and  
Capitola Police Captains

**PUBLIC EMPLOYEE PERFORMANCE EVALUATION (Govt. Code §54957)**

City Council’s Performance Evaluation of the City Attorney

Vice Mayor Storey noted that there was no one in the audience; therefore, the City Council recessed at 6:05 p.m. to the City Manager’s Office.

**REGULAR MEETING OF THE CAPITOLA CITY COUNCIL – 7:00 PM**

**1. ROLL CALL AND PLEDGE OF ALLEGIANCE**

Council Members Dennis Norton, Ed Bottorff, Michael Termini, and Vice Mayor Sam Storey. Mayor Stephanie Harlan was absent.

City Treasurer Kym DeWitt was absent.

**2. PRESENTATIONS**

A. Introduction of Senior Accountant, Kyle Solberg.

B. Proclamation recognizing Childhood Cancer Awareness Week from May 5 through May 11, 2013. [120-40]

Proclamation was read by Vice Mayor Storey, and the City Clerk will mail the proclamation to the KCC Family House and Wellness Center.

C. Proclamation designating May 15, 2013, as “Paint the Town Purple” to promote public awareness for the American Cancer Society’s Relay For Life upcoming events. [120-40]

Proclamation was read by Vice Mayor Storey and received by Linda Fridy, a Relay for Life representative.



3. REPORT ON CLOSED SESSION [520-25]

Assistant City Attorney Paterno stated that the Council discussion anticipated litigation regarding the Surf and Sand Mobile Home Park; no reportable action was taken. Council discussed a conference with the labor negotiator regarding the Capitola Police Officers Association and the Capitola Police Captains; no reportable action was taken. The Council discussed the City Attorney's performance evaluation; no reportable action was taken.

4. ADDITIONS AND DELETIONS TO AGENDA (none provided)

5. PUBLIC COMMENTS

Goran, Soquel resident, thanked the Capitola Police Departments for their service to the community.

Marilyn Garrett, local resident, spoke against wireless radiation and the use of pesticides.

Brian MacKenzie, Capitola Village Residents Association (CVRA), stated that the CVRA will hold its next Neighbors' Night Dinner on May 22<sup>nd</sup> at Britiannia Arms.

Paul Pelkey, local resident, spoke against violence.

6. COUNCIL/STAFF ANNOUNCEMENTS

City Clerk Sneddon announced that the American Red Cross will be holding a blood drive on June 5<sup>th</sup> at the Community Center.

Police Chief Escalante stated that on May 11<sup>th</sup> the Capitola Police Department will conduct a voluntary gun take back at Shore Life Church between 10 a.m. and 2 p.m.

Council Member Termini stated that on May 16<sup>th</sup> the Capitola Art & Wine Festival Kick-off Party will be held at Bargetto Winery in Soquel. He stated that Detective Leo Moreno of the Capitola Police Department is helping to organize the Special Olympics Law Enforcement Torch Run; the run will be coming through Capitola on June 19<sup>th</sup>. He also stated that the Santa Cruz Public Libraries has a new smart phone app so that the public can easily access the library system to request/reserve books. He requested information about the City's proposed parking meters to be purchased for the upper Pacific Cove Parking lot.

Public Works Director Jesberg provided an update regarding the purchasing of pay stations and parking meters for the City.

Council Member Termini asked Finance Director Hannah about CalPERS prepayment options.

Finance Director Hannah replied that alternate uses of the settlement funds, which will include the CalPERS prepayment option, will take place at the May 22<sup>nd</sup> City Council Budget Study Session.

Council Member Norton stated that the Santa Cruz County Regional Transportation (SCCRTC) has submitted for a \$21 million grant application to fund the development of 15 miles of bicycle and pedestrian trails from Davenport to the Santa Cruz Wharf.

7. BOARDS, COMMISSIONS AND COMMITTEES APPOINTMENTS (none provided)

**8. CONSENT CALENDAR**

**ACTION** Motion made by Council Member Termini, seconded by Vice Mayor Storey, to approve the Consent Calendar with the correction to the April 25, 2013, City Council minutes regarding the Lexington Insurance Company Settlement Agreement. The vote was unanimous.

- A. Consideration of approving the City Council Minutes of the April 25, 2013, Regular Meeting.
- B. Receive Planning Commission Action Minutes of the May 2, 2013, Regular Meeting. [740-50]
- C. Consideration of an Ordinance amending Section 18.02.070 of the Capitola Municipal Code pertaining to Affordable (Inclusionary) Housing Regulations [2nd Reading]. [750-10]
- D. Receive the California Public Employees Retirement System Annual Actuarial Valuation Reports as of June 30, 2012. [630-10]

**9. GENERAL GOVERNMENT/PUBLIC HEARINGS**

- A. Consideration of approving the General Special Event Permit for the AIDS/Lifecycle event on June 3, 2013, sponsored by the San Francisco AIDS Foundation. [1050-70]

**ACTION** Motion made by Council Member Norton, seconded by Council Member Termini, to approve the General Special Event Permit for the AIDS/Lifecycle event on June 3, 2013, sponsored by the San Francisco AIDS Foundation. The vote was unanimous.

- B. Discussion regarding the benches at Peery Park and the public restrooms at Nob Hill. [1040-20]

**ACTION** Motion made by Council Member Termini, seconded by Vice Mayor Storey, to permanently remove the picnic tables from Peery Park; and to continue to have the restrooms next to Nob Hill open during park hours from 6 a.m. to sunset. The motion carried with the following vote: **AYES: Council Members Bottorff, Termini, and Vice Mayor Storey. NOES: Council Member Norton. ABSENT: Mayor Harlan. ABSTAIN: None.**

- C. Consideration of approving the implementation of the Patient Protection and Affordable Health Care Act. [630-10]

Administrative Service Director Murphy stated that beginning in 2014 President Obama's Patient Protection and Affordable Care Act goes into effect with the intent to improve the health care delivery system. The law requires all employers with 50 or more full-time employees to offer affordable health care. Staff has determined that there is one employee in the Recreation Division who fits this category; therefore, staff recommends this employee become a permanent, benefited employee and receive health care benefits.

**ACTION** Motion made by Council Member Bottorff, seconded by Council Member Termini, to approve the implementation of the Patient Protection and Affordable Health Care Act; change an hourly Recreation position to a permanent 0.75 full-time position; provide affordable health care insurance for this position. The motion carried with the following vote: **AYES: Council Members Norton, Bottorff, Termini, and Vice Mayor Storey. NOES: None. ABSENT: Mayor Harlan. ABSTAIN: None.**

**10. COUNCIL/STAFF COMMUNICATIONS**

Community Development Director Grunow stated that the City received a request for a conditional use permit, a coastal development permit, and a design permit from Monarch Cove Hotel to add an additional 32 rooms. A request for approval to issue a contract for a consultant to prepare the Environmental Impact Report is tentatively scheduled for the June 27<sup>th</sup> City Council Meeting.

**11. CITY COUNCIL/TREASURER COMMENTS/COMMITTEE REPORTS**

**12. ADJOURNMENT**

Vice Mayor Storey adjourned the meeting at 8:20 p.m. to the Special Budget Study Session of the City Council and the Successor Agency to be held on Wednesday, May 22, 2013, at 6:00 p.m., in the City Hall Council Chambers, 420 Capitola Avenue, Capitola, California.

\_\_\_\_\_  
Sam Storey, Vice Mayor

ATTEST:

\_\_\_\_\_, CMC  
Susan Sneddon, City Clerk





## CITY COUNCIL AGENDA REPORT

### MEETING OF MAY 23, 2013

FROM: FINANCE DEPARTMENT  
SUBJECT: CITY CHECK REGISTER REPORT

**RECOMMENDED ACTION:** Approve the attached Check Register Reports for Apr 19, Apr 25, May 3, and May 10, 2013

**DISCUSSION:** Check Registers are attached for:

Date	Starting Check #	Ending Check #	Total Checks/EFT	Amount
4/19/13	72666	72734	69	\$141,962.68
4/25/13	72735	72775	41	\$93,514.99
5/3/13	72776	72846	71	\$100,522.40
5/10/13	72847	72912	67	\$188,645.53

The check register of Apr 12, 2013 ended with check #72665

Following is a list of checks issued for more than \$10,000.00, and a brief description of the expenditure:

Check	Issued to:	Dept.	Purpose	Amount
72720	SC Regional 911	PD	4 <sup>th</sup> Qtr Operating+Debt Service	\$80,433.40
72748	Gumbiner & Eskridge LLP	CM	Legal Svcs, Ins Loss Claim	\$65,930.77
72817	PG&E	PW	Monthly Electric	\$12,539.66
72825	SCC Conf & Visitor Council	CM	Transient Mkt District Pass Thru	\$23,380.89
72864	Design, Comm & Environ.	CDD	Gen Plan Update Services	\$64,073.10
72892	New World Systems	IT	Maint Contract, Fin System	\$14,200.00
EFT	CalPERS Health Ins	CM	Employee Health Ins	\$50,704.60

**ATTACHMENTS:**

1. Check Register for Apr 19, 2013
2. Check Register for Apr 25, 2013
3. Check Register for May 3, 2013
4. Check Register for May 10, 2013

Report Prepared By: Linda Benko  
AP Clerk

Reviewed and Forwarded  
by City Manager: 

THIS PAGE INTENTIONALLY LEFT BLANK

Checks dated 4/19/13 numbered 72666 to 72734 for a total of \$141,962.68 have been reviewed and authorized for distribution by the City Manager and City Treasurer.

As of 4/19/13 the unaudited cash balance is \$1,886,710

**CASH POSITION - CITY OF CAPITOLA 4/19/13**

	<u>Net Balance</u>
General Fund	537,050
Contingency Reserve Fund	671,646
Worker's Comp. Ins. Fund	31,225
Self Insurance Liability Fund	169,475
Stores Fund	(7,398)
Information Technology Fund	61,673
Equipment Replacement	110,664
Compensated Absences Fund	12,775
Public Employee Retirement - PERS	-
Open Space Fund	256
Capital Improvement Projects	299,345
TOTAL GENERAL FUND & COUNCIL DESIGNATED FUNDS	<u>1,886,710</u>

The Emergency Reserve Fund balance is \$289,295.54 and is not included above.

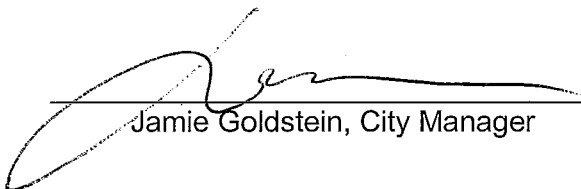
  
 \_\_\_\_\_  
 Jamie Goldstein, City Manager

4/19/2013  
 \_\_\_\_\_  
 Date

\_\_\_\_\_  
 Kymberly V. DeWitt, City Treasurer

\_\_\_\_\_  
 Date



## City Checks Issued 4/19/2013

Check Number	Invoice Number	Status	Invoice Date	Description	Payee Name	Transaction Amount
72666	04/19/2013 Invoice 891734-5	Open	Date 04/02/2013	Description Lift rental 4/2/13	A TOOL SHED	\$160.00
72667	04/19/2013 Invoice 4967	Open	Date 04/04/2013	Description Brooms for Street Sweeper Fund 1310, Gas Tax	ACME ROTARY BROOM SERVICE	\$1,814.21
72668	04/19/2013 Invoice 981851510-2013	Open	Date 03/04/2013	Description Volunteers Ins Bond Fund 2213, Self-Insurance Liability	ALLIED INSURANCE	\$1,096.00
72669	04/19/2013 Invoice 674-Apr2013	Open	Date 04/01/2013	Description Long Distance, April 2013	AT&T	\$3.81
72670	04/19/2013 Invoice 1268	Open	Date 03/31/2013	Description Pac Cove MHP Closure Services 1420, Pac Cove Bond	AUTOTEMP INC.	\$172.50
72671	04/19/2013 Invoice 280982	Open	Date 03/21/2013	Description Bar Oil	B & B SMALL ENGINE REPAIR	\$32.36
72672	04/19/2013 Invoice 17	Open	Date 04/02/2013	Description Re-Usable Shopping Bags	BAGSPEAK/BAGITO	\$830.00
72673	04/19/2013 Invoice 2013-00000635	Open	Date 04/15/2013	Description Early Spring Instructor Payments	BARRETT, SHARON	\$39.00
72674	04/19/2013 Invoice 2013-00000585 3031419 3031417 3042608	Open	Date 03/21/2013 03/21/2013 03/21/2013 03/28/2013	Description Museum Display Expense Museum Display Expense Museum Display Expense Museum Display Expense	BAY PHOTO LAB	\$165.28
72675	04/19/2013 Invoice 2013-00000630	Open	Date 04/12/2013	Description Softball Umpires April 1 to 13 2013	BEYERS, FRED, C	\$132.00
72676	04/19/2013 Invoice 11331 11200 13372 14475 14933 15143	Open	Date 03/20/2013 03/20/2013 03/25/2013 03/27/2013 03/27/2013 03/28/2013	Description Wood, Depot Hill & Cliff Lumber, Grand Ave. Wood - Grand Ave. Wood - Grand Ave. Misc. supplies - Grand Ave. fence Wood - Grand Ave.	BIG CREEK LUMBER	\$1,986.46

# City Checks Issued 4/19/2013

Check Number	Invoice Number	Status	Invoice Date	Description	Payee Name	Transaction Amount
72677	04/19/2013 Invoice 7570	Open	Date 04/02/2013	Description Pac Cove Lower Pkg Lot Fund 1200, CIP	BOWMAN & WILLIAMS, INC.	\$4,479.00
72678	04/19/2013 Invoice 69670	Open	Date 03/21/2013	Description Supplies for JG Comp	BRINKS AWARDS & SIGNS	\$578.09
72679	04/19/2013 Invoice 2013-00000629	Open	Date 04/12/2013	Description Softball Umpires April 1 to 13 2013	BUMGARNER, ERIC	\$132.00
72680	04/19/2013 Invoice POA4-19-13	Open	Date 04/17/2013	Description POA Dues, Employee Funded	CAPITOLA PEACE OFFICERS ASSOC.	\$985.50
72681	04/19/2013 Invoice 2013-00000637	Open	Date 04/15/2013	Description Early Spring Instructor Payments	CHARLEBOIS, FREDERIC	\$112.50
72682	04/19/2013 Invoice 1221	Open	Date 03/26/2013	Description SCC Yellow Pages Re-Cycle Guide	CITY OF SCOTTS VALLEY	\$130.44
72683	04/19/2013 Invoice 2013-00000636	Open	Date 04/15/2013	Description Early Spring Instructor Payments	CLARK, DAVE	\$60.45
72684	04/19/2013 Invoice 11005	Open	Date 03/31/2013	Description March 2013 Cleaning Service	CLEAN BUILDING MAINTENANCE	\$3,648.34
72685	04/19/2013 Invoice 1345949	Open	Date 03/26/2013	Description Cleaning supplies	CLEAN SOURCE	\$953.39
72686	04/19/2013 Invoice Mar2013	Open	Date 03/31/2013	Description March 2013 Drinking Water	CRYSTAL SPRINGS WATER CO.	\$135.00
72687	04/19/2013 Invoice 1462819	Open	Date 04/08/2013	Description Employee Medical Exam	DOCTORS EXPRESS	\$195.00
72688	04/19/2013 Invoice 12-3948	Open	Date 04/15/2013	Description JG patches	EMBROIDERY WORKS	\$995.90
72689	04/19/2013 Invoice 6083707	Open	Date 04/01/2013	Description Irrigation supplies	EWING IRRIGATION	\$4.77

## City Checks Issued 4/19/2013

Check Number	Invoice Number	Status	Invoice Date	Description	Payee Name	Transaction Amount
72690	04/19/2013 Invoice 599961	Open	Date 04/10/2013	Description Plants	FARWEST NURSERY	\$25.09
72691	04/19/2013 Invoice 21	Open	Date 04/12/2013	Description Mar2013 BIA Services Fund 3121, BIA	FERRASCI-HARP, AMY	\$800.00
72692	04/19/2013 Invoice 13-835113 13-835112	Open	Date 04/05/2013 04/05/2013	Description 110 Gal Diesel 510 Gal Ethanol	FLYERS ENERGY, LLC	\$2,505.18
72693	04/19/2013 Invoice 20130403	Open	Date 04/03/2013	Description Reimb BIA Expenses Fund 1321, BIA	HANNA, CARIN	\$518.88
72694	04/19/2013 Invoice 2013-00000638	Open	Date 04/15/2013	Description Early Spring Instructor Payments	HOWELLS, NANCY	\$59.80
72695	04/19/2013 Invoice ICMA4-19-13	Open	Date 04/17/2013	Description Retirement Plan Contr, Employee Funded	ICMA RETIREMENT TRUST 457	\$4,649.55
72696	04/19/2013 Invoice 50232244	Open	Date 03/25/2013	Description Batteries, F-800 Dump Truck	INTERSTATE BATTERY SYSTEM	\$173.49
72697	04/19/2013 Invoice 40413 40313	Open	Date 04/04/2013 04/03/2013	Description Hill Street Coast Live Oak Assessment Arborist Services, Cap Ave Live Oak	JAMES P ALLEN & ASSOC	\$360.00
72698	04/19/2013 Invoice 173042 173041 174865	Open	Date 02/04/2013 02/04/2013 02/11/2013	Description Rec Copier Exp, Feb-Mar13 Contract C12t Copier Fee, Feb-Apr13, City Hall Contract Copier Cost, City hall, Feb-May13, Contrac Fund 2211, IT	KBA Docusys	\$206.59
72699	04/19/2013 Invoice A177040 A177042 A177138	Open	Date 04/02/2013 04/02/2013 04/03/2013	Description Painting supplies, New Brighton Gym Painting supplies, New Brighton Gym Paint - New Brighton Gym	KING'S PAINT AND PAPER, INC.	\$333.82
72700	04/19/2013 Invoice 2013-00000639	Open	Date 04/15/2013	Description Early Spring Instructor Payments	KRAFT, MARC	\$114.40



## City Checks Issued 4/19/2013

Check Number	Invoice Number	Status	Invoice Date	Description	Payee Name	Transaction Amount
72701	04/19/2013	Open			LEHR AUTO ELECTRIC & EMERGENC'	\$1,277.35
	Invoice		Date	Description		Amount
	01-081748		03/25/2013	Vehicle purchase-PD		\$253.86
	01-081459		03/15/2013	Equipment for new vehicle		\$1,023.49
				Fund 2212, Equip Replacement		
72702	04/19/2013	Open			LLOYD'S TIRE SERVICE INC.	\$139.81
	Invoice		Date	Description		Amount
	243780		03/26/2013	New Tire, PD Impala		\$139.81
72703	04/19/2013	Open			LOOMIS	\$922.39
	Invoice		Date	Description		Amount
	11220287		03/31/2013	Armored car service, Apr2013		\$922.39
72704	04/19/2013	Open			LUICH, JAY	\$132.00
	Invoice		Date	Description		Amount
	2013-00000631		04/12/2013	Softball Umpires April 1 to 13 2013		\$132.00
72705	04/19/2013	Open			McMENAMIN, GEORGE	\$375.00
	Invoice		Date	Description		Amount
	14a		04/16/2013	Soquel Creek Restoration		\$375.00
72706	04/19/2013	Open			MID-COUNTY AUTO SUPPLY	\$209.34
	Invoice		Date	Description		Amount
	336349		03/27/2013	Parts, Toyota Camry		\$11.33
	336144		03/26/2013	Headlight, Silver Impala		\$26.04
	335714		03/22/2013	Auto parts, PD Crown Vic		\$14.20
	335594		03/21/2013	Auto Parts, Fleet		\$149.16
	336977		04/03/2013	Ball hitch		\$8.61
72707	04/19/2013	Open			MONTEREY BAY SYSTEMS	\$1,366.08
	Invoice		Date	Description		Amount
	168073		03/27/2013	City Hall Copier, CLP31DN, Contract 2016		\$338.00
	168071		03/27/2013	PD Copier Exp, C452, Contract 21883-01		\$692.90
	168072		03/27/2013	PD Copier, SC400DN, Contract 11057-07		\$335.18
				Fund 1000, Gen Fund=\$1028.08		
				Fund 2211, IT=\$338.00		
72708	04/19/2013	Open			ORCHARD SUPPLY HARDWARE	\$262.71
	Invoice		Date	Description		Amount
	6007-1026050		03/28/2013	Irrigation supplies		\$15.23
	6007-1026168		03/28/2013	Utility sink		\$108.49
	6013-2298672		03/29/2013	Paint		\$22.41
	6010-6066724		04/01/2013	Lumber Rack for F-250		\$38.33
	6009-1021691		04/02/2013	Lumber Rack, F-250		\$40.76
	6009-1022397		04/04/2013	Auto Parts, PW F-250		\$37.49
72709	04/19/2013	Open			PACIFIC PRODUCTS AND SERVICES	\$1,832.54
	Invoice		Date	Description		Amount
	16189		03/21/2013	Steel rivets		\$422.04
	16202		03/25/2013	Aluminum channel		\$1,410.50
				Fund 1310, Gas Tax		

## City Checks Issued 4/19/2013

Check Number	Invoice Number	Status	Invoice Date	Description	Payee Name	Transaction Amount
72710	04/19/2013	Open			PALACE ART & OFFICE SUPPLIES	\$68.16
	Invoice		Date	Description		Amount
	206288-1		03/28/2013	file boxes-PD		\$21.61
	206288		03/26/2013	Office supplies-PD		\$46.55
72711	04/19/2013	Open			PAPE MACHINERY	\$1,468.86
	Invoice		Date	Description		Amount
	8438499		04/01/2013	John Deere Loader Parts		\$1,468.86
72712	04/19/2013	Open			PHOENIX GROUP INFORMATION SYS	\$1,067.31
	Invoice		Date	Description		Amount
	22013070		03/20/2013	Citation Surcharges, Feb 2013		\$1,067.31
72713	04/19/2013	Open			ProBUILD COMPANY LLC	\$155.50
	Invoice		Date	Description		Amount
	5709459		04/04/2013	Glasteel		\$50.86
	5710525		04/09/2013	Wood		\$82.33
	5708520		04/01/2013	Shop Supplies, Corp Yd		\$22.31
72714	04/19/2013	Open			QUARTARARO, ROD	\$176.00
	Invoice		Date	Description		Amount
	2013-00000627		04/12/2013	Softball Umpires April 1 to 13 2013		\$176.00
72715	04/19/2013	Open			REED, DANIEL	\$132.00
	Invoice		Date	Description		Amount
	2013-00000628		04/12/2013	Softball Umpires April 1 to 13 2013		\$132.00
72716	04/19/2013	Open			ROGERS, ANDERSON, MALODY & SCOTT, LLP	\$6,580.00
	Invoice		Date	Description		Amount
	37683		02/28/2013	Audit, Final Prep		\$6,580.00
72717	04/19/2013	Open			ROM, HILLEL	\$112.50
	Invoice		Date	Description		Amount
	2013-00000632		04/12/2013	Volleyball, Futsal Officials Feb16 to March		\$112.50
72718	04/19/2013	Open			ROYAL WHOLESALE ELECTRIC	\$224.21
	Invoice		Date	Description		Amount
	7719-569475		03/18/2013	Floor Lamps		\$61.85
	7719-569492		03/18/2013	CPD electrical		\$68.56
	7719-569583		03/21/2013	City Hall electrical		\$93.80
72719	04/19/2013	Open			SCC AUDITOR-CONTROLLER	\$7,861.50
	Invoice		Date	Description		Amount
	Mar2013		04/12/2013	Citation Surcharges, Mar2013		\$7,861.50
72720	04/19/2013	Open			SANTA CRUZ REGIONAL 911	\$80,433.40
	Invoice		Date	Description		Amount
	20130315-Q4		03/15/2013	4th qrt operating for 2012/13		\$59,471.40
	20130315		03/15/2013	Second half Debt Service FY 2012/13		\$20,962.00

## City Checks Issued 4/19/2013

Check Number	Invoice Number	Status	Invoice Date	Description	Payee Name	Transaction Amount
72721	04/19/2013 Invoice 2895	Open	Date 03/22/2013	Description Uniform Exp, Farotte-PD	SUMMIT UNIFORM CORP	\$236.80
72722	04/19/2013 Invoice 2013-00000633	Open	Date 04/12/2013	Description Volleyball, Futsal Officials Feb16 to March	THILL, WENDY	\$240.00
72723	04/19/2013 Invoice 6484Summer	Open	Date 04/12/2013	Description Postage for Summer brochure	UNITED STATES POSTAL SERVICE	\$4,640.00
72724	04/19/2013 Invoice Apr2013	Open	Date 04/17/2013	Description Employee Contr to UW, Apr 2013	UNITED WAY OF SANTA CRUZ COUN	\$60.00
72725	04/19/2013 Invoice UPEC4-19-13	Open	Date 04/17/2013	Description Union Dues, Employee Funded	UPEC LIUNA LOCAL 792	\$972.00
72726	04/19/2013 Invoice PARS4-19-13	Open	Date 04/12/2013	Description Retirement Plan Contr, Employee Funded	US Bank Institutional Trust-Western Reg	\$451.62
72727	04/19/2013 Invoice 38895	Open	Date 03/22/2013	Description Prints, 504 Beulah	WATSONVILLE BLUEPRINT	\$27.48
72728	04/19/2013 Invoice 5643	Open	Date 04/02/2013	Description 46th & Topaz, Curb and apron replacemen Fund 1310, Gas Tax	WHITLOW CONCRETE, INC.	\$1,400.00
72729	04/19/2013 Invoice 2013-00000634	Open	Date 04/15/2013	Description Supplies	Edwards, Kurt	\$148.42
72730	04/19/2013 Invoice 20130409	Open	Date 04/12/2013	Description Reimb Cake for Museum Reception	Kisling, Niels	\$165.00
72731	04/19/2013 Invoice 2001622-002	Open	Date 04/15/2013	Description Class refund	Luiten, Thea	\$57.00
72732	04/19/2013 Invoice 2001624-002	Open	Date 04/15/2013	Description Class refund	Rickman, Jacqueline	\$63.90
72733	04/19/2013 Invoice 2001629-002	Open	Date 04/15/2013	Description JG transfer S1 to S2	Waldron, Patricia	\$50.00

# City Checks Issued 4/19/2013

Check Number	Invoice Number	Status	Invoice Date	Description	Payee Name	Transaction Amount
72734	04/19/2013	Open			TALMADGE CONSTRUCTION, INC.	\$65.00
	Licensee Type		4/15/2013	Description		Amount
	Business			Business License Refund		\$65.00
Check Totals:				Count	69	Total \$141,962.68

Checks dated 4/25/13 numbered 72735 to 72775 for a total of \$93,514.99 have been reviewed and authorized for distribution by the City Manager and City Treasurer.

As of 4/25/13 the unaudited cash balance is \$3,062,694

**CASH POSITION - CITY OF CAPITOLA 4/26/13**

	<u>Net Balance</u>
General Fund	1,714,873
Contingency Reserve Fund	671,646
Worker's Comp. Ins. Fund	31,225
Self Insurance Liability Fund	169,475
Stores Fund	(9,031)
Information Technology Fund	61,467
Equipment Replacement	110,664
Compensated Absences Fund	12,775
Public Employee Retirement - PERS	-
Open Space Fund	256
Capital Improvement Projects	299,345
<b>TOTAL GENERAL FUND &amp; COUNCIL DESIGNATED FUNDS</b>	<u><u>3,062,694</u></u>

The Emergency Reserve Fund balance is \$289,295.54 and is not included above.

  
 \_\_\_\_\_  
 Tori Hannah, Finance Director

4/25/2013  
 \_\_\_\_\_  
 Date

\_\_\_\_\_  
 Kimberley V. DeWitt, City Treasurer

\_\_\_\_\_  
 Date



## City Checks Issued 4/26/2013

Check Number	Invoice Number	Status	Invoice Date	Description	Payee Name	Transaction Amount
72735	04/26/2013 Invoice 186820	Open	Date 03/31/2013	Description Credit Checks, New Hires	ADVANTAGE CREDIT INC.	\$20.00 \$20.00
72736	04/26/2013 Invoice 2669	Voided	Incorrect Amount Date 04/11/2013	04/26/2013 Description Asbestos Sampling, Pac Cove	AERO-ENVIRONMENTAL CONSULTING	\$0.00 \$1,625.00
72737	04/26/2013 Invoice 44624 44703	Open	Date 04/03/2013 04/18/2013	Description New door handle for interview room-PD Keys-PD	ALLSAFE LOCK COMPANY	\$193.80 \$128.85 \$64.95
72738	04/26/2013 Invoice 39786	Open	Date 04/22/2013	Description Meter Reading, Capitola Wharf Fund 1311, Wharf Fund	AUTOMATED TEST ASSOCIATES	\$25.00 \$25.00
72739	04/26/2013 Invoice Mar2013	Open	Date 04/08/2013	Description Credit Card Charges, March 2013 Fund 1000, Gen Fund=\$2680.66 Fund 2211, IT=\$206.10	BANK OF AMERICA	\$2,886.76 \$2,886.76
72740	04/26/2013 Invoice 3044551 3021198 3041602	Open	Date 03/29/2013 03/14/2013 03/27/2013	Description Museum Display Expense Museum Display Expense Museum Display Expense	BAY PHOTO LAB	\$106.30 \$79.12 \$9.79 \$17.39
72741	04/26/2013 Invoice 967194	Open	Date 04/10/2013	Description 11550 H & S Analysis	CA DEPARTMENT OF JUSTICE	\$17.00 \$17.00
72742	04/26/2013 Invoice 1302 1289	Open	Date 03/29/2013 03/25/2013	Description Uniform Exp, Valdez Uniform Exp, Rannals (Pkg)	CALIFORNIA COAST UNIFORM CO.	\$219.90 \$160.28 \$59.62
72743	04/26/2013 Invoice R212676	Open	Date 12/21/2012	Description 9 Bronze Plaques	CRESTOR INC.	\$1,545.48 \$1,545.48
72744	04/26/2013 Invoice 64700	Open	Date 03/28/2013	Description Fuel Storage Tank Test & Inspection	DONLEE PUMP COMPANY	\$1,250.82 \$1,250.82
72745	04/26/2013 Invoice 88285	Open	Date 03/27/2013	Description Rukus badge K-9	ENTENMANN-ROVIN	\$65.75 \$65.75

# City Checks Issued 4/26/2013

Check Number	Invoice Number	Status	Invoice Date	Description	Payee Name	Transaction Amount
72746	04/26/2013	Open			EQUIPTec MECHANICAL INC.	\$1,453.00
	Invoice		Date	Description		Amount
	200439		04/18/2013	Refund Business License Overpayment		\$1,453.00
72747	04/26/2013	Open			FLYERS ENERGY, LLC	\$4,389.72
	Invoice		Date	Description		Amount
	13-837053		04/12/2013	505 Gal Ethanol		\$2,035.20
	13-833980		03/29/2013	47 Gal Diesel		\$202.58
	13-833979		03/29/2013	508 Gal Ethanol		\$2,151.94
72748	04/26/2013	Open			GUMBINER & ESKRIDGE LLP	\$65,930.77
	Invoice		Date	Description		Amount
	11338		04/09/2013	Legal Services, Insurance Loss Claim		\$65,930.77
72749	04/26/2013	Open			LABORMAX STAFFING	\$1,869.18
	Invoice		Date	Description		Amount
	26-21066		04/12/2013	Temp Labor, Corp Yd		\$1,869.18
72750	04/26/2013	Open			LARSENS INC.	\$1,296.50
	Invoice		Date	Description		Amount
	Quote3727		04/18/2013	Art Project		\$1,296.50
				Fund 1315, Public Art		
72751	04/26/2013	Open			MID-COUNTY AUTO SUPPLY	\$265.23
	Invoice		Date	Description		Amount
	336495		03/28/2013	Auto Parts, 2011 Toyota Camry		\$24.61
	336748		04/01/2013	Auto Parts, PD Toyota camry		\$43.16
	337465		04/08/2013	Drop Lite Bulbs, Shop		\$7.69
	336924		04/02/2013	Auto Parts, PW Vehicles		\$189.77
72752	04/26/2013	Open			ORCHARD SUPPLY HARDWARE	\$614.58
	Invoice		Date	Description		Amount
	6007-3526862		04/01/2013	General supplies		\$36.94
	6013-7829221		04/02/2013	Dremel		\$152.24
	6012-4799507		04/02/2013	General supplies		\$30.42
	6012-4799513		04/02/2013	Shop Faucet		\$18.56
	6009-4791913		04/03/2013	Wasp spray		\$15.20
	6009-4791944		04/03/2013	General supplies		\$6.60
	6008-2292582		04/03/2013	Misc. Maint Supplies		\$9.68
	6012-2549806		04/04/2013	Misc. Cleaning Supplies		\$21.71
	6014-5592137		04/08/2013	Wrecking Bar		\$32.61
	6012-4791225		04/09/2013	Street painting supplies		\$154.53
	6008-5593232		04/09/2013	General supplies		\$42.37
	6014-2432421		04/10/2013	General supplies		\$29.86
	6005-8198607		04/10/2013	General supplies		\$30.18
	6014-2432721		04/11/2013	General supplies		\$33.68

## City Checks Issued 4/26/2013

Check Number	Invoice Number	Status	Invoice Date	Description	Payee Name	Transaction Amount
72753	04/26/2013	Open			PALACE ART & OFFICE SUPPLIES	\$309.15
	Invoice		Date	Description		Amount
	207746		04/05/2013	Office Supplies, City Hall		\$26.62
	207912		04/08/2013	Office Supplies, City Hall		\$19.79
	208279		04/09/2013	Office Supplies, City hall		\$56.28
	207586		04/04/2013	Office supplies-PD		\$132.09
	C207746		04/10/2013	Return Office Supplies		(\$7.53)
	8893047		04/10/2013	Office Supplies, Museum		\$56.08
	210244		04/22/2013	Batteries, City Hall		\$25.82
				Fund 1000, Gen Fund=\$188.17		
				Fund 2210, Stores=\$120.98		
72754	04/26/2013	Open			PITNEY BOWES INC.	\$479.21
	Invoice		Date	Description		Amount
	461880		04/01/2013	Postage Meter Maintenance Contract		\$479.21
				Fund 2210, Stores Fund		
72755	04/26/2013	Open			PODS ENTERPRISES INC.	\$162.04
	Invoice		Date	Description		Amount
	050-330373		04/15/2013	May 2013 Rental		\$162.04
72756	04/26/2013	Open			POLAR AUTOMOTIVE & RADIATOR	\$203.36
	Invoice		Date	Description		Amount
	21438		04/11/2013	Radiator Cap, F-350 Flatbed		\$203.36
72757	04/26/2013	Open			QUILL CORPORATION	\$60.84
	Invoice		Date	Description		Amount
	1676471		04/04/2013	name plates for temp evidence lockers		\$60.84
72758	04/26/2013	Open			RAY ALLEN MANUFACTURING LLC	\$199.90
	Invoice		Date	Description		Amount
	290891		04/09/2013	K-9 supplies		\$199.90
72759	04/26/2013	Open			ROBERT SEELEY & ASSOCIATES	\$105.00
	Invoice		Date	Description		Amount
	2013-008		04/15/2013	Admin Hearings, Q1 CY2013		\$105.00
72760	04/26/2013	Open			SANDRETTI, BRANTLY	\$607.72
	Invoice		Date	Description		Amount
	20130301		03/01/2013	Reimb Travel Exp, Traffic Investigation Co		\$607.72
72761	04/26/2013	Open			SANTA CRUZ SENTINEL	\$251.36
	Invoice		Date	Description		Amount
	4814962		03/29/2013	Employment Ad, Maint Worker 1 and 2		\$251.36
72762	04/26/2013	Open			SIEMENS INDUSTRY INC.	\$1,396.48
	Invoice		Date	Description		Amount
	400099184		03/28/2013	Mar 2013 Routine Signal Maint		\$698.24
	400096839		02/26/2013	Feb 2013 Routine Signal Maint		\$698.24
				Fund 1310, Gas Tax		

# City Checks Issued 4/26/2013

Check Number	Invoice Number	Status	Invoice Date	Description	Payee Name	Transaction Amount
72763	04/26/2013	Open			THE HARTFORD-PRIORITY ACCOUNT	\$1,435.70
	Invoice		Date	Description		Amount
	6299590-7		04/18/2013	May 2013 Employee Life & Disability ins.		\$1,435.70
72764	04/26/2013	Open			TRI-COUNTY BUSINESS SYSTEMS INC	\$1,032.24
	Invoice		Date	Description		Amount
	CNIN037633		03/29/2013	Copier Contract, Q3 FY12/13, City Hall cop		\$1,032.24
				Fund 2210, Stores		
72765	04/26/2013	Open			By the Beach Productions, LLC	\$1,500.00
	Invoice		Date	Description		Amount
	2013-00000650		04/15/2013	Refund Bandstand Deposit Women on Wa		\$1,500.00
72766	04/26/2013	Open			City of Folsom Police Department	\$172.00
	Invoice		Date	Description		Amount
	2013-00000644		04/11/2013	Zamora & Thompson PTO school POST		\$172.00
72767	04/26/2013	Open			Ellis, John and Sarah	\$125.00
	Invoice		Date	Description		Amount
	2013-00000653		04/10/2013	Refund payment made to DMV in error		\$125.00
72768	04/26/2013	Open			Kaemmerling, Corinne	\$55.00
	Invoice		Date	Description		Amount
	2013-00000646		04/22/2013	Rec Camp Exp Transfer		\$55.00
72769	04/26/2013	Open			Larkspur Landing Folsom	\$753.20
	Invoice		Date	Description		Amount
	2013-00000654		04/22/2013	Zamora, Thompson PTO school POST		\$753.20
72770	04/26/2013	Open			Martinez, Stephanie	\$74.00
	Invoice		Date	Description		Amount
	2013-00000648		04/22/2013	Class refund		\$74.00
72771	04/26/2013	Open			Rooke, Annie	\$500.00
	Invoice		Date	Description		Amount
	2013-00000647		04/22/2013	Tree Permit Deposit Refund #13-039		\$500.00
72772	04/26/2013	Open			Thornton, John	\$250.00
	Invoice		Date	Description		Amount
	2013-00000649		04/19/2013	Refund for civil subpoena		\$250.00
72773	04/26/2013	Open			Van Sandt, Julie	\$71.00
	Invoice		Date	Description		Amount
	2013-00000651		04/22/2013	Class refund		\$71.00
72774	04/26/2013	Open			Winans, Thomas	\$97.00
	Invoice		Date	Description		Amount
	2013-00000652		04/22/2013	Class refund		\$97.00
72775	04/26/2013	Open			AERO-ENVIRONMENTAL CONSULTING	\$1,525.00
	Invoice		Date	Description		Amount
	2669c		04/11/2013	Asbestos Survey Sampling, Pac Cove		\$1,525.00
				Fund 1420, Pac Cove Bond		
Type Check Totals:				Count	41	TOTAL \$93,514.99

THIS PAGE INTENTIONALLY LEFT BLANK



Checks dated 5/3/13 numbered 72776 to 72846 for a total of \$100,522.40 have been reviewed and authorized for distribution by the City Manager and City Treasurer.

As of 5/3/13 the unaudited cash balance is \$2,884,772

**CASH POSITION - CITY OF CAPITOLA 5/3/13**

	<u>Net Balance</u>
General Fund	1,542,961
Contingency Reserve Fund	671,646
Worker's Comp. Ins. Fund	31,225
Self Insurance Liability Fund	169,475
Stores Fund	(9,435)
Information Technology Fund	58,255
Equipment Replacement	108,270
Compensated Absences Fund	12,775
Public Employee Retirement - PERS	-
Open Space Fund	256
Capital Improvement Projects	299,345
TOTAL GENERAL FUND & COUNCIL DESIGNATED FUNDS	<u><u>2,884,772</u></u>

The Emergency Reserve Fund balance is \$289,295.54 and is not included above.

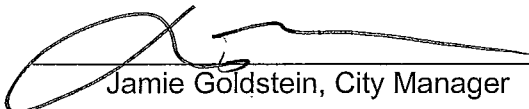
  
 \_\_\_\_\_  
 Jamie Goldstein, City Manager

5/3/2013  
 \_\_\_\_\_  
 Date

\_\_\_\_\_  
 Kymberly V. DeWitt, City Treasurer

\_\_\_\_\_  
 Date

## City Checks Issued 5/3/2013

Check Number	Invoice Number	Status	Invoice Date	Description	Payee Name	Transaction Amount
72776	05/03/2013	Open			WESTSIDE BEAUTY SUPPLY	\$285.00
	Licensee Type		Date	Description	Transaction Type	
	Business		4/26/2013	Refund Overpayment	Refund	
72777	05/03/2013	Open			A TOOL SHED	\$198.70
	Invoice		Date	Description	Amount	
	895100-5		04/17/2013	Dump truck rental	\$198.70	
72778	05/03/2013	Open			AFLAC	\$466.76
	Invoice		Date	Description	Amount	
	427040		04/18/2013	Suppl Ins, April 2013, Employee Funded	\$466.76	
72779	05/03/2013	Open			ALLSAFE LOCK COMPANY	\$80.00
	Invoice		Date	Description	Amount	
	44698		04/16/2013	Keys, Crown Vic	\$80.00	
72780	05/03/2013	Open			APTOS LANDSCAPE SUPPLY, INC.	\$597.54
	Invoice		Date	Description	Amount	
	351318		04/23/2013	Firbark	\$298.77	
	351338		04/23/2013	Firbark	\$298.77	
72781	05/03/2013	Open			B & B SMALL ENGINE REPAIR	\$245.38
	Invoice		Date	Description	Amount	
	282919		04/16/2013	Chainsaw chains	\$123.48	
	283550		04/23/2013	JD mower blades	\$121.90	
72782	05/03/2013	Open			BEVERLY FABRICS INC.	\$750.01
	Invoice		Date	Description	Amount	
	42213		04/22/2013	Sonic Wall	\$750.01	
				Fund 2211, IT		
72783	05/03/2013	Open			CALIFORNIA COAST UNIFORM CO	\$72.81
	Invoice		Date	Description	Amount	
	1352		04/08/2013	Uniform Exp, Moreno (PD)	\$53.23	
	1351		04/08/2013	Uniform Exp, Sandretti (Pkg)	\$19.58	
72784	05/03/2013	Open			CALIF LAW ENFORCEMENT ASSOC	\$514.50
	Invoice		Date	Description	Amount	
	May2013		04/18/2013	Long Term Disability Ins, PD	\$514.50	
72785	05/03/2013	Open			CALIF SOCIETY OF MUNICIPAL FINANCE OFF.	\$105.00
	Invoice		Date	Description	Amount	
	May2013		04/30/2013	Meeting Registration, 3 participants	\$105.00	
72786	05/03/2013	Open			CAPITOLA PEACE OFFICERS ASSOC	\$1,463.75
	Invoice		Date	Description	Amount	
	POA5-3-13		05/02/2013	POA Dues, Employee Funded	\$1,463.75	
72787	05/03/2013	Open			Charter Communications	\$135.00
	Invoice		Date	Description	Amount	
	0198562-May13		04/11/2013	Internet Access	\$135.00	
				Fund 2211, IT		

# City Checks Issued 5/3/2013

Check Number	Invoice Number	Status	Invoice Date	Description	Payee Name	Transaction Amount
72788	05/03/2013 Invoice 1351862	Open	Date 04/05/2013	Description Cleaning supplies	CLEAN SOURCE	\$1,325.77
72789	05/03/2013 Invoice 8807-2	Open	Date 04/24/2013	Description Asbestos Abatement, Pac Cove MHP, Cha Fund 1420, Pac Cove Bond	COASTWIDE ENVIRONMENTAL TECH	\$3,100.00
72790	05/03/2013 Invoice 28750-64	Open	Date 04/29/2013	Description GPAC webhosting 4/23/13-5/22/13 Fund 1313, General Plan Update	CRUZIO THE INTERNET STORE INC.	\$39.95
72791	05/03/2013 Invoice 6147467	Open	Date 04/10/2013	Description Drip Irrigation tubing	EWING IRRIGATION	\$17.21
72792	05/03/2013 Invoice 2-245-12711	Open	Date 04/18/2013	Description March Shipping Exp	FEDERAL EXPRESS	\$164.11
72793	05/03/2013 Invoice 2798540	Open	Date 04/19/2013	Description Faucets Fund 1311, Wharf Fund	FERGUSON ENTERPRISES, INC.	\$339.02
72794	05/03/2013 Invoice 13-838910 13-838917	Open	Date 04/18/2013 04/18/2013	Description 496 Gal Ethanol 190 Gal Diesel	FLYERS ENERGY, LLC	\$2,712.70
72795	05/03/2013 Invoice 175	Open	Date 04/30/2013	Description Postcard Design, Art at the Beach	FREEMAN, THELMA	\$113.75
72796	05/03/2013 Invoice 108096	Open	Date 04/17/2013	Description Mar 2013 Legal Services	GOLDFARB & LIPMAN, LLP	\$1,512.00
72797	05/03/2013 Invoice 20130425	Open	Date 04/30/2013	Description Reimb Mileage Exp, Planning Dir Meeting	GRUNOW, RICH	\$39.55
72798	05/03/2013 Invoice 317671	Open	Date 04/01/2013	Description Network Service Charge Fund 2211, IT	HAINES & COMPANY, INC.	\$1,021.03
72799	05/03/2013 Invoice 20681	Open	Date 04/05/2013	Description Capitola PMP Uddate Fund 1310, Gas Tax	HARRIS & ASSOCIATES	\$1,363.38

## City Checks Issued 5/3/2013

Check Number	Invoice Number	Status	Invoice Date	Description	Payee Name	Transaction Amount
72800	05/03/2013 Invoice 32662	Open	Date 04/11/2013	Description Floating dock supplies Fund 1311, Wharf Fund	HENDERSON MARINE SUPPLY	\$142.58 \$142.58
72801	05/03/2013 Invoice ICMA5-3-13	Open	Date 05/02/2013	Description Retirement Plan Contr, Employee Funded	ICMA RETIREMENT TRUST 457	\$4,629.64 \$4,629.64
72802	05/03/2013 Invoice 1308005	Open	Date 04/09/2013	Description Planner Ads	JOBS AVAILABLE	\$315.00 \$315.00
72803	05/03/2013 Invoice A174243 A177694 A177553	Open	Date 02/11/2013 04/12/2013 04/10/2013	Description Red curb paint-Fund 1310 Gas Tax Floating dock supplies-Fund 1311, Wharf f Painting supplies-General Fund	KING'S PAINT AND PAPER, INC.	\$272.68 \$124.27 \$78.94 \$69.47
72804	05/03/2013 Invoice 26-21212	Open	Date 04/19/2013	Description Temp Labor, Corp Yard	LABORMAX STAFFING	\$1,885.68 \$1,885.68
72805	05/03/2013 Invoice 01082244 01081937 01082223 01082425 01082222 01004940	Open	Date 04/04/2013 04/28/2013 04/04/2013 04/10/2013 04/04/2013 04/18/2013	Description Electronics, new PD vehicle Electronics, new PD vehicle Electronics, new PD vehicle Electronics, new PD vehicle Electronics, new PD vehicle Returns Fund 2212, Equip Replacement	LEHR AUTO ELECTRIC & EMERGENC'	\$2,393.77 \$709.04 \$645.79 \$445.01 \$221.84 \$584.15 (\$212.06)
72806	05/03/2013 Invoice 20678	Open	Date 04/18/2013	Description Tree removal	LEWIS TREE SERVICE INC.	\$2,050.00 \$2,050.00
72807	05/03/2013 Invoice LIUNA-Apr2013	Open	Date 04/30/2013	Description Pension Dues, April 2013	LIUNA PENSION FUND	\$240.00 \$240.00
72808	05/03/2013 Invoice 244695	Open	Date 04/12/2013	Description Kabota Tractor Tires	LLOYD'S TIRE SERVICE INC.	\$562.03 \$562.03
72809	05/03/2013 Invoice 20130422	Open	Date 04/22/2013	Description Parking Lot Rent, 820 Bay Ave.	LOMAK PROPERTY GROUP, INC.	\$4,892.00 \$4,892.00
72810	05/03/2013 Invoice 81922	Open	Date 04/04/2013	Description Advertising	Mainstreet Media dba GOODTIMES	\$200.00 \$200.00

# City Checks Issued 5/3/2013

Check Number	Invoice Number	Status	Invoice Date	Description	Payee Name	Transaction Amount
72811	05/03/2013 Invoice 41650971	Open	Date 04/03/2013	Description Supplies-Rec	MEDCO SUPPLY CO.	\$575.19
72812	05/03/2013 Invoice 338110 338114 337171 337131 337839 337756	Open	Date 04/12/2013 04/12/2013 04/04/2013 04/04/2013 04/10/2013 04/10/2013	Description Auto Parts, PD Vehicles Auto Parts, PW Vehicles Auto Parts, PW F-250 Auto Parts, PW F-250 Auto Parts, Toyota Camry Auto Parts, PD071	MID-COUNTY AUTO SUPPLY	\$558.99
72813	05/03/2013 Invoice 10	Open	Date 05/02/2013	Description Inspections Services, Public Works	MORRISON, EDWARD	\$2,500.00
72814	05/03/2013 Invoice 1304003	Open	Date 04/01/2013	Description Software Support Fund 2211, IT	MUNIMETRIX SYSTEMS CORP.	\$499.00
72815	05/03/2013 Invoice 30416	Open	Date 04/10/2013	Description Sales Tax reporting service, Q4 2012	MUNISERVICES, LLC	\$1,162.64
72816	05/03/2013 Invoice 6012-4793275 6009-3595091 6014-1023850 6008-5593903 6012-4792584 6014-1023866 6011-3591632 6007-5650624 6008-3524004	Open	Date 04/18/2013 04/16/2013 04/15/2013 04/15/2013 04/15/2013 04/15/2013 04/22/2013 04/22/2013 04/17/2013	Description Crack filler Paint supplies-Fund 1311, Wharf Fund Shovel Trailer Hitch Installation Supplies Hitch for Public Works Trailer Misc Supplies, PW Vehicles PD, New Command Vehicle Auto Parts, PD New Command Vehicle Misc Supplies, IT-Fund 2211, IT	ORCHARD SUPPLY HARDWARE	\$232.39
72817	05/03/2013 Invoice 2013-00000661	Open	Date 04/22/2013	Description Monthly Elec Fund 1000, Gen Fund=\$4049.81 Fund 1300, SLESF=\$113.58 Fund 1310, Gas Tax=\$6611.42 Fund 1311, Wharf Fund=\$1764.85	PACIFIC GAS & ELECTRIC	\$12,539.66
72818	05/03/2013 Invoice 2013-00000662	Open	Date 04/22/2013	Description Pac Cove MHP Elec and Gas	PACIFIC GAS & ELECTRIC	\$127.28



## City Checks Issued 5/3/2013

Check Number	Invoice Number	Status	Invoice Date	Description	Payee Name	Transaction Amount
72819	05/03/2013	Open			PALACE ART & OFFICE SUPPLIES	\$772.02
	Invoice		Date	Description		Amount
	209471		04/17/2013	Office Supplies, Corp Yd		\$162.35
	209154		04/16/2013	Paper-PD		\$46.65
	210125		04/22/2013	Office supplies-PD		\$191.63
	210293		04/25/2013	Office supplies-PD		\$59.81
	211116		04/26/2013	Office supplies		\$125.15
	8892318		04/08/2013	Supplies for Chamber Art Display		\$22.19
	8892848		04/10/2013	Supplies for Chamber Art Display		\$6.49
	210280		04/24/2013	Misc Supplies, City Hall		\$23.93
	210656		04/24/2013	Pens, City Hall		\$11.30
	210351-0		05/01/2013	Office Supplies		\$122.52
				Fund 1000, General Fund=\$574.44		
				Fund 2210, Stores=\$197.58		
72820	05/03/2013	Open			PAPE MACHINERY	\$1,468.86
	Invoice		Date	Description		Amount
	8438501		04/01/2013	Parts for John Deere Loader		\$1,468.86
72821	05/03/2013	Open			PITNEY BOWES INC.	\$206.40
	Invoice		Date	Description		Amount
	410147		04/03/2013	Rental Charge, Postage Meter		\$206.40
				Fund 2210, Stores		
72822	05/03/2013	Open			ProBUILD COMPANY LLC	\$72.54
	Invoice		Date	Description		Amount
	5713305		04/19/2013	Wood - paint stencils		\$29.19
	5716144		04/29/2013	Washers-Fund 1311, Wharf Fund		\$43.35
72823	05/03/2013	Open			QUALITY CODE PUBLISHING LLC	\$3,827.30
	Invoice		Date	Description		Amount
	2013-108		04/09/2013	Suppl Service to Capitola Muni Code		\$3,827.30
72824	05/03/2013	Open			ROYAL WHOLESALE ELECTRIC	\$916.83
	Invoice		Date	Description		Amount
	7719-569626		03/25/2013	Exit lights		\$332.01
	7719-569703		03/27/2013	Exit light		\$110.67
	7719-569862		04/01/2013	Ballasts		\$153.50
	7719-569933		04/04/2013	Lights		\$81.40
	7719-569872		04/01/2013	Floodlights		\$239.25
72825	05/03/2013	Open			SCC CONFERENCE & VISITORS COUNCIL	\$23,380.89
	Invoice		Date	Description		Amount
	Q3 FY12/13TMD		04/15/2013	Q3 FY12/13 TMD		\$19,068.39
	10346		04/18/2013	Q3 FY12/13 Funding		\$4,312.50
72826	05/03/2013	Open			SCC DEPT OF PUBLIC WORKS	\$28.00
	Invoice		Date	Description		Amount
	412786		04/16/2013	Survey maps, prints & copies		\$28.00

# City Checks Issued 5/3/2013

Check Number	Invoice Number	Status	Invoice Date	Description	Payee Name	Transaction Amount
72827	05/03/2013	Open			SERVICESYS, LLC	\$600.00
	Invoice		Date	Description		Amount
	2493		04/07/2013	IT Support		\$600.00
				Fund 2211, IT		
72828	05/03/2013	Open			SHERMAN, LEONIE	\$250.00
	Invoice		Date	Description		Amount
	March 2013		03/31/2013	Self defense classes		\$250.00
72829	05/03/2013	Open			SHERWIN-WILLIAMS	\$1,523.86
	Invoice		Date	Description		Amount
	5397-6		04/11/2013	Hotline Latex White Paint		\$1,523.86
				Fund 1310, Gas Tax		
72830	05/03/2013	Open			SIEMENS INDUSTRY INC.	\$1,084.04
	Invoice		Date	Description		Amount
	400100442		04/12/2013	March T/S Extra Work, Signal Maint		\$1,084.04
				Fund 1310, Gas Tax		
72831	05/03/2013	Open			SPORT ABOUT EQUIPMENT	\$1,344.71
	Invoice		Date	Description		Amount
	22151KM		01/11/2013	Softballs		\$1,344.71
72832	05/03/2013	Open			SPRING VALLEY WHOLESALE NURSERY	\$552.08
	Invoice		Date	Description		Amount
	3894		04/18/2013	Six Trees		\$552.08
72833	05/03/2013	Open			SPRINT	\$2,784.83
	Invoice		Date	Description		Amount
	974855313-136		04/05/2013	Cell Phone Service		\$2,784.83
72834	05/03/2013	Open			STAPLES	\$123.46
	Invoice		Date	Description		Amount
	3359634001a		03/13/2013	Computer Supplies		\$2.64
	3525372001		03/18/2013	Computer Supplies		\$32.50
	3525372002		03/18/2013	Computer Supplies		\$54.23
	39081		03/25/2013	Computer Supplies		\$34.09
				Fund 2211, IT		
72835	05/03/2013	Open			THE INTERNET CONNECTION INC.	\$150.00
	Invoice		Date	Description		Amount
	3917-16157		05/01/2013	City Website Hosting		\$150.00
72836	05/03/2013	Open			The URBAN EXPLORER, Inc.	\$4,100.00
	Invoice		Date	Description		Amount
	20130415		04/15/2013	GIS web hosting & licensing		\$4,100.00
72837	05/03/2013	Open			UNITED PARCEL SERVICE	\$33.32
	Invoice		Date	Description		Amount
	954791163		04/20/2013	Shipping		\$33.32

## City Checks Issued 5/3/2013

Check Number	Invoice Number	Status	Invoice Date	Description	Payee Name	Transaction Amount	
72838	05/03/2013	Open			US BANCORP EQUIPMENT FINANCE	\$439.30	
	Invoice		Date	Description		Amount	
	227041985		04/21/2013	Copier Maint, IR1750, Contract 500-03323		\$98.97	
	225889443		04/04/2013	Copier Contract, PD Copier, Contract 500-		\$259.85	
	225889336		04/04/2013	Copier Contract, City Hall Copier, Contract		\$80.48	
72839	05/03/2013	Open			US Bank Inst. Trust-Western Region	\$412.34	
	Invoice		Date	Description		Amount	
	PAR55-3-13		05/02/2013	PARS Contribution, Employee Funded		\$412.34	
72840	05/03/2013	Open			Anderson, F J	\$100.00	
	Invoice		Date	Description		Amount	
	1		05/02/2013	Art at the Beach Postcard Design		\$100.00	
72841	05/03/2013	Open			Forrest, Craig & Tara	\$500.00	
	Invoice		Date	Description		Amount	
	2013-00000657		04/29/2013	Tree Permit #13-028 refund		\$500.00	
72842	05/03/2013	Open			Genge, Joe and Debbie	\$1,285.50	
	Invoice		Date	Description		Amount	
	2013-00000655		04/29/2013	Application #12-020 Withdrawn - refund fe		\$1,285.50	
72843	05/03/2013	Open			Harrison, Darrell	\$44.17	
	Invoice		Date	Description		Amount	
	2013-00000660		04/29/2013	Harrison fixed Irao's wheelchair; parts		\$44.17	
72844	05/03/2013	Open			Kellengerger, Steve	\$1,754.50	
	Invoice		Date	Description		Amount	
	2013-00000656		04/29/2013	Application #13-047 withdrawn-refund		\$1,754.50	
72845	05/03/2013	Open			Rubio, Amy	\$271.00	
	Invoice		Date	Description		Amount	
	2013-00000658		05/01/2013	Refund-Rec		\$271.00	
72846	05/03/2013	Open			Star, Rachel	\$55.00	
	Invoice		Date	Description		Amount	
	2013-00000659		05/01/2013	Refund-Rec		\$55.00	
Type Check Totals:				Count	71	Total	\$100,522.40

Checks dated 5/10/13 numbered 72847 to 72912 plus an EFT for a total of \$188,645.53 have been reviewed and authorized for distribution by the City Manager and City Treasurer.

As of 5/10/13 the unaudited cash balance is \$2,882,600

**CASH POSITION - CITY OF CAPITOLA 5/10/13**

	<u>Net Balance</u>
General Fund	1,325,543
Contingency Reserve Fund	671,646
Worker's Comp. Ins. Fund	163,250
Self Insurance Liability Fund	198,703
Stores Fund	(822)
Information Technology Fund	78,470
Equipment Replacement	133,434
Compensated Absences Fund	12,775
Public Employee Retirement - PERS	-
Open Space Fund	256
Capital Improvement Projects	299,345
<b>TOTAL GENERAL FUND &amp; COUNCIL DESIGNATED FUNDS</b>	<u><u>2,882,600</u></u>

The Emergency Reserve Fund balance is \$289,295.54 and is not included above.

  
 \_\_\_\_\_  
 Jamie Goldstein, City Manager

5/10/2013  
 \_\_\_\_\_  
 Date

\_\_\_\_\_  
 Kymberly V. DeWitt, City Treasurer

\_\_\_\_\_  
 Date

## City Checks Issued 5/10/13

Check Number	Invoice Number	Status	Invoice Date	Description	Payee Name	Transaction Amount
72847	05/10/2013 Invoice 186883	Open	Date 04/30/2013	Description Background check for VIP	ADVANTAGE CREDIT INC.	\$20.00
72848	05/10/2013 Invoice 44708 44675	Open	Date 04/22/2013 04/01/2013	Description Keys, Black Crown Vic Rec Keys	ALLSAFE LOCK COMPANY	\$92.99
72849	05/10/2013 Invoice 351964	Open	Date 04/30/2013	Description Fir bark	APTOS LANDSCAPE SUPPLY, INC.	\$567.23
72850	05/10/2013 Invoice 4275747 4192455	Open	Date 04/13/2013 03/13/2013	Description Apr Telephone Service Mar Telephone Service Fund 1000, Gen Fund=\$3482.04 Fund 2211, IT=\$512.82	AT&T/CALNET 2	\$3,994.86
72851	05/10/2013 Invoice 284245	Open	Date 05/01/2013	Description Parts	B & B SMALL ENGINE REPAIR	\$12.87
72852	05/10/2013 Invoice 28774 C1614	Open	Date 04/24/2013 03/28/2013	Description Lumber-Fund 1311, Wharf Fund Credit for returned lumber	BIG CREEK LUMBER	\$13.92
72853	05/10/2013 Invoice G-80879	Open	Date 04/19/2013	Description Hang tags-PD	BORDEN DECAL	\$215.70
72854	05/10/2013 Invoice 957794	Open	Date 03/05/2013	Description Rossi to refund fingerprint fees	CA DEPARTMENT OF JUSTICE	\$352.00
72855	05/10/2013 Invoice 128977 129099 129235	Open	Date 03/28/2013 04/16/2013 04/29/2013	Description March active pay stations Service call April 2013 active meters	CALE AMERICA INC.	\$1,599.26
72856	05/10/2013 Invoice 1386 1146 1147	Open	Date 04/19/2013 02/19/2013 02/19/2013	Description Uniform Exp, Sandretti (Pkg) Uniform Exp, Volunteer (Chin), PD Uniform Exp, Volunteer (Chaplain), PD	CALIFORNIA COAST UNIFORM CO	\$376.00

# City Checks Issued 5/10/13

Check Number	Invoice Number	Status	Invoice Date	Description	Payee Name	Transaction Amount
72857	05/10/2013 Invoice 2013-00000665	Open	Date 05/06/2013	Description Brochure Printing-Rec	CASEY PRINTING	\$44.00
72858	05/10/2013 Invoice 15624-Apr2013	Open	Date 05/01/2013	Description Animal Control Exp, Apr 2013	CHANTICLEER VET HOSPITAL	\$1,285.25
72859	05/10/2013 Invoice 1351862-01 1357800	Open	Date 04/16/2013 04/19/2013	Description Cleaning supplies Cleaning supplies	CLEAN SOURCE	\$1,549.80
72860	05/10/2013 Invoice 8077011	Open	Date 04/12/2013	Description Parking hang tags	COMMUNITY PRINTERS	\$263.19
72861	05/10/2013 Invoice R213706	Open	Date 04/18/2013	Description 6 Bronze Plaques, Mem Benches	CRESTOR INC.	\$1,032.71
72862	05/10/2013 Invoice 2989-147 28750-66	Open	Date 04/24/2013 05/02/2013	Description Website Hosting GPAC webhosting 5/23/13-6/22/13 Fund 1000, Gen Fund=\$65.70 Fund 1313, Gen Plan Update=\$44.95	CRUZIO THE INTERNET STORE INC.	\$110.65
72863	05/10/2013 Invoice 3080 3080a	Open	Date 04/25/2013 05/03/2013	Description first aid items-PD Correct Total on Previous Inv.	CVS PHARMACY INC.	\$31.15
72864	05/10/2013 Invoice 50628 50922	Open	Date 02/28/2013 03/15/2013	Description Professional Services 2/1/13-2/28/13 Professional Services 3/1/13-3/31/13 Fund 1313, Gen Plan Update	DESIGN, COMMUNITY & ENVIRONMEI	\$64,073.10
72865	05/10/2013 Invoice Q1-2013	Open	Date 04/30/2013	Description Q1 2013 State Unemployment Fund 2213, Self Ins Liability	EMPLOYMENT DEVELOPMENT DEPT	\$5,272.00
72866	05/10/2013 Invoice May 2013	Open	Date 04/23/2013	Description Evidence storage	EXTRA SPACE STORAGE OF SC INC	\$303.00
72867	05/10/2013 Invoice 599957	Open	Date 04/10/2013	Description Plants	FARWEST NURSERY	\$128.20



## City Checks Issued 5/10/13

Check Number	Invoice Number	Status	Invoice Date	Description	Payee Name	Transaction Amount
72868	05/10/2013 Invoice	Open			FASTENAL COMPANY	\$54.34
	CASAT19907		04/16/2013	PD Crown Vics		\$18.97
	CASAT19936		04/18/2013	Auto Parts, Fleet		\$35.37
72869	05/10/2013 Invoice	Open			FERGUSON ENTERPRISES, INC.	\$115.17
	2803157		04/25/2013	Plumbing supplies		\$115.17
72870	05/10/2013 Invoice	Open			FERRASCI-HARP, AMY	\$950.00
	22		05/02/2013	April Marketing Support, BIA Fund 1321, BIA		\$950.00
72871	05/10/2013 Invoice	Open			FIRST ALARM	\$117.87
	618880		03/15/2013	Qtrly Alarm Monitoring, PD Capitola Mall		\$117.87
72872	05/10/2013 Invoice	Open			FLYERS ENERGY, LLC	\$2,731.31
	13-841379		04/25/2013	200 Gal Diesel		\$738.37
	13-841378		04/25/2013	492 Gal Ethanol		\$1,992.94
72873	05/10/2013 Invoice	Open			FLYNN, CAROLYN	\$5,260.00
	CBF-4-2013		04/30/2013	Professional Services April 1-30, 2013 Fund 1000, Gen Fund=\$2760 Fund 1313, Gen Plan=\$300 Fund 5552, Cap Hsg Succ=\$2200		\$5,260.00
72874	05/10/2013 Invoice	Open			GLADWELL GOVERNMENT SERVICES	\$750.00
	2724		04/15/2013	Legal review of records retention schedule		\$750.00
72875	05/10/2013 Invoice	Open			GRAHAM-GARCIA, BARBARA	\$250.00
	154		04/19/2013	Ergonomic Eval, Wilson-PD		\$250.00
72876	05/10/2013 Invoice	Open			GROWING UP IN SANTA CRUZ	\$420.00
	1088		05/06/2013	Camp Ad-Rec		\$420.00
72877	05/10/2013 Invoice	Open			INTERSTATE BATTERY SYSTEMS	\$228.27
	50232804		04/22/2013	Two Batteries, PD Units		\$228.27
72878	05/10/2013 Invoice	Open			KBA Docusys	\$25.92
	189862		05/01/2013	Copier expense Fund 2211, IT		\$25.92

## City Checks Issued 5/10/13

Check Number	Invoice Number	Status	Invoice Date	Description	Payee Name	Transaction Amount
72879	05/10/2013	Open			KELLY-MOORE PAINTS	\$341.98
	Invoice		Date	Description		Amount
	803-00000455920		04/24/2013	Paint rig parts		\$341.98
72880	05/10/2013	Open			KING'S CLEANERS	\$826.50
	Invoice		Date	Description		Amount
	Apr 2013		04/14/2013	Uniform cleaning-PD		\$826.50
72881	05/10/2013	Open			KING'S PAINT AND PAPER, INC.	\$458.99
	Invoice		Date	Description		Amount
	A177826		04/15/2013	Floating dock paint		\$204.11
	A178142		04/19/2013	Painting supplies		\$6.98
	A178361		04/23/2013	Spray tips		\$44.36
	A177267		04/05/2013	Painting supplies		\$67.63
	A178901		05/01/2013	Graffiti paint		\$135.91
				Fund 1000, Gen Fund=\$187.25		
				Fund 1311, Wharf=\$271.74		
72882	05/10/2013	Open			LABORMAX STAFFING	\$2,078.12
	Invoice		Date	Description		Amount
	26-21374		04/26/2013	Temp Labor, PW		\$2,078.12
72883	05/10/2013	Open			LEHR AUTO ELECTRIC & EMERGENC'	\$947.10
	Invoice		Date	Description		Amount
	01082568		04/12/2013	New PD vehicle electronics		\$947.10
				Fund 2212, Equip Replacement		
72884	05/10/2013	Open			MEGAPATH COVAD COMMUNICATION	\$646.51
	Invoice		Date	Description		Amount
	March2013		03/28/2013	Internet connectivity		\$646.51
				Fund 2211, IT		
72885	05/10/2013	Open			METROPOLITAN TRANS COMMISSION	\$2,000.00
	Invoice		Date	Description		Amount
	AR8711		04/12/2013	StreetSaver Subscription		\$2,000.00
72886	05/10/2013	Open			MID-COUNTY AUTO SUPPLY	\$324.87
	Invoice		Date	Description		Amount
	338087		04/12/2013	Auto Supplies, Shop		\$123.56
	338113		04/12/2013	Auto Parts, PW Vehicles		\$27.13
	337758		04/10/2013	Auto Parts, PD071		\$7.88
	338322		04/15/2013	Auto Parts, New PD Vehicles		\$75.88
	338381		04/15/2013	Auto Parts, New PD Vehicles		\$43.35
	338782		04/18/2013	PW Wacker Roller		\$8.76
	338377		04/15/2013	Auto Parts, PD Vehicles		\$30.17
	338467		04/16/2013	Auto Parts, PD Vehicles		\$8.14
72887	05/10/2013	Open			MISSION LINEN SUPPLY	\$867.36
	Invoice		Date	Description		Amount
	Apr2013		05/01/2013	April 2013 Uniform and Mat cleaning servic		\$867.36
72888	05/10/2013	Open			Montano Plumbing, Inc.	\$383.78
	Invoice		Date	Description		Amount
	23421		05/06/2013	PR valve, Esplanade Shower Tower		\$383.78

## City Checks Issued 5/10/13

Check Number	Invoice Number	Status	Invoice Date	Description	Payee Name	Transaction Amount
72889	05/10/2013 Invoice MBA11-1229	Open	Date 04/11/2013	Description Claim Settlement, Jimenez Fund 2213, Self Ins Liab	MONTEREY BAY AREA SELF INS AUTI	\$1,557.57
72890	05/10/2013 Invoice MBA11-1229z	Open	Date 04/29/2013	Description Claim Settlement, Jimenez Fund 2213, Self Ins Liab	MONTEREY BAY AREA SELF INS AUTI	\$554.28
72891	05/10/2013 Invoice 30527	Open	Date 04/19/2013	Description District Sales Tax Audit	MUNISERVICES, LLC	\$207.75
72892	05/10/2013 Invoice 26341	Open	Date 04/15/2013	Description Annual Maintenance Contract, Finance Sy: Fund 2211, IT	NEW WORLD SYSTEMS	\$14,200.00
72893	05/10/2013 Invoice 6012-4794473 6014-3596933 6009-3596718 6012-4094959 6005-4760737	Open	Date 04/23/2013 04/29/2013 04/24/2013 04/25/2013 04/29/2013	Description Misc. earplugs for the range-PD Shop Supplies, Fleet Auto Parts, PD 2011 Tahoe Auto Parts, PD New Command Vehicle	ORCHARD SUPPLY HARDWARE	\$186.36
72894	05/10/2013 Invoice 211442 8899611 211586 19347	Open	Date 04/30/2013 04/30/2013 05/01/2013 05/06/2013	Description office supplies-PD office supplies-PD Office supplies Keyboard tray	PALACE ART & OFFICE SUPPLIES	\$333.30
72895	05/10/2013 Invoice 32013070	Open	Date 04/15/2013	Description Citation Charges, March 2013	PHOENIX GROUP INFORMATION SYS	\$1,526.12
72896	05/10/2013 Invoice 5715245 5715627	Open	Date 04/25/2013 04/26/2013	Description Nuts & bolts Rope Fund 1311, Wharf Fund	ProBUILD COMPANY LLC	\$239.04
72897	05/10/2013 Invoice RS-7654	Open	Date 04/26/2013	Description Radar trailer parts	RADAR SHOP	\$362.75
72898	05/10/2013 Invoice 1566741 1566740 1571516 1571517	Open	Date 04/01/2013 04/01/2013 05/01/2013 05/01/2013	Description Internet Access Internet Access-Fund 2211, IT Internet Access-Fund 2211, IT Internet Access Fund 1000, Gen Fund=\$99.88	RED SHIFT INTERNET SERVICES	\$230.22

## City Checks Issued 5/10/13

Check Number	Invoice Number	Status	Invoice Date	Description	Payee Name	Transaction Amount
72899	05/10/2013 Invoice 22728	Open	Date 03/31/2013	Description Labor Negotiations	RENNE SLOAN HOLTZMAN SAKAI	\$2,100.58
72900	05/10/2013 Invoice 65338	Open	Date 04/24/2013	Description Health Permit Invoice, Corp Yd	SCC ENVIRONMENTAL HEALTH SVC	\$1,137.00
72901	05/10/2013 Invoice SCAN-May 2013	Open	Date 04/30/2013	Description May 2013 Query scan charges	SCC INFORMATION SERVICES	\$521.99
72902	05/10/2013 Invoice 400100555	Open	Date 04/13/2013	Description Feb2013 Signal Maint. Fund 1310, Gas Tax Fund	SIEMENS INDUSTRY INC.	\$665.05
72903	05/10/2013 Invoice 93030-May2013	Open	Date 05/01/2013	Description May 2013 Dental & Vision Ins, Employee F	TLC ADMINISTRATORS, INC.	\$5,249.22
72904	05/10/2013 Invoice 18327	Open	Date 05/01/2013	Description Cafeteria Plan Admin Fee	TLC ADMINISTRATORS, INC.	\$175.00
72905	05/10/2013 Invoice 2	Open	Date 05/01/2013	Description Professional Services April 2013	TSCHANTZ, KIM CARLOS	\$1,775.00
72906	05/10/2013 Invoice 954791173	Open	Date 04/27/2013	Description shipping-PD	UNITED PARCEL SERVICE	\$15.48
72907	05/10/2013 Invoice capit13-04 capo13-02	Open	Date 04/28/2013 05/03/2013	Description Monthly Canine Maint-March 2013 Purchase of K-9 for Weagle Fund 1300, SLESF=\$4000	VIGILANT CANINE SERVICES	\$4,250.00
72908	05/10/2013 Invoice 2013-00000663	Open	Date 05/03/2013	Description Refund Project Application #12-140	Byrne, Mary	\$1,180.00
72909	05/10/2013 Invoice 2013-00000664	Open	Date 05/03/2013	Description Cell Phone waterproof cover & holder	Garcia, Eddie Ray	\$118.77
72910	05/10/2013 Invoice 2013-00000666	Open	Date 05/06/2013	Description Class Refund	Jackson, Maia	\$86.00

# City Checks Issued 5/10/13

Check Number	Invoice Number	Status	Invoice Date	Description	Payee Name	Transaction Amount
72911	05/10/2013 Invoice 2013-00000667	Open	Date 05/06/2013	Description Camp Refund	Raw Gourment, Wonderfully	\$73.00
72912	05/10/2013 Invoice 227092186	Open	Date 04/23/2013	Description Rec Copier Contract, 500-0296803-000 Fund 2211, IT	US BANCORP EQUIPMENT FINANCE,	\$80.48
201305	05/06/2013 Invoice May2013	Open	Date 04/15/2013	Description May 2013 Health Ins, Employee Funded	CalPERS Health Insurance	\$50,704.60
Check Totals:				Count	67	TOTAL \$188,645.53



## CITY COUNCIL AGENDA REPORT

MEETING OF MAY 23, 2013

FROM: FINANCE DEPARTMENT

SUBJECT: CONFIRMATION OF CITY'S INVESTMENT POLICY

---

**RECOMMENDED ACTION:** Confirm the City's Investment Policy (Administrative Policy Number III-1; Revised August 9, 2001), or provide direction to staff regarding any recommended changes.

**BACKGROUND:** California Government Code §53630 et seq contains State requirements for the deposit of City funds. GC § 53635 requires that all money belonging to, or in the custody of, a local agency be deposited in certain allowable instruments. The current Investment Policy was approved by the City Council on August 9, 2001, by adoption of Resolution No. 3149 affirming the City's Investment Policy, and was incorporated into the City's Administrative Policies. A copy of the Investment Policy, which was confirmed by the City Council on May 24, 2012, is attached.

**DISCUSSION:** The California Government Code requires cities to review its Investment Policy on an annual basis. The purpose of this item is to provide the City Council with an opportunity to review its policy and either reaffirm the Investment Policy or provide direction to staff for recommended changes. The City's current Investment Policy and Investment Portfolio comply with all applicable state law requirements.

**FISCAL IMPACT:** None

**ATTACHMENTS**

1. Administrative Policy III-1: Investment Policy (Confirmed 5/24/12)

Report Prepared By: Lonnie Wagner  
Accountant II

Reviewed and Forwarded  
By City Manager: 

THIS PAGE INTENTIONALLY LEFT BLANK



## ADMINISTRATIVE POLICY

Number: III-1

Issued: May 9, 1996

Revised: August 9, 2001

Confirmed: May 24, 2012

Jurisdiction: City Council

INVESTMENT POLICY

The policy for the investment of public funds shall at all times conform, by law, to Section 53601, et seq., of the California Government Code. In order of importance, the investment policy shall:

1. Provide for the safety of the funds
2. Assure the liquidity of the funds
3. Acquire earnings of the funds

This investment policy, or any modification thereof, shall be formulated by the City Treasurer and approved by the City Council and copies made available upon request.

The Treasurer's investment portfolio contains pooled investments of funds by both the City and of benefit assessment districts within the City. The earnings from pooled investments are shared proportionately with each investor.

City investment funds shall only be invested in the following permitted investments:

1. State of California Local Agency Investment Fund
2. U.S. Treasury T-Bills
3. Negotiable Certificates of Deposit
4. Guaranteed Investment Contracts (GIC) of AAA quality, for a term not to exceed fifteen (15) months\*

The following limitations shall apply to permitted investments:

T-Bills: Total dollar investment not to exceed 60% of total portfolio at time of investment.

Certificates of Deposit:

- A. Total dollar investment not to exceed 20% of total portfolio at time of investment.
- B. Maturity date of securities shall not be more than 365 days from date of purchase.
- C. Issuer must be one of top 20 national or state chartered banks, one of top 20 state or federal savings associations, or one of top 10 state licensed foreign banks as compiled by American Banker from Merrill Lynch.
- D. CD's may be purchased only from the issuer, a federal or state chartered bank, a federal or state association, or a brokerage firm designated as a primary dealer by the Federal Reserve Bank.
- E. The deposit shall not exceed the total of the paid-up capital and the surplus of any depository bank, nor shall the deposit exceed the net worth of any depository association.

Jacques Bertrand, City Treasurer

[City Council Resolution No. 2788, 5/9/96; Amended 3/22/01 by Resolution No. 3120 and 8/9/01 by Resolution No. 3149; Confirmed: 6/12/03; 6/10/04; 6/9/05; 5/25/06; 5/24/07; 6/12/08; 5/28/09; 5/13/10; 5/26/11, 5/24/12]

R:\Admin Policies\III-1 Investment Policy 5-24-12.doc



THIS PAGE INTENTIONALLY LEFT BLANK



## CITY COUNCIL AGENDA REPORT

MEETING OF MAY 23, 2013

FROM: CITY MANAGER'S DEPARTMENT

SUBJECT: THIRD AMENDMENT TO THE AGREEMENT FOR CITY ATTORNEY SERVICES WITH ATCHISON, BARISONE, CONDOTTI & KOVACEVICH, AND AUTHORIZE THE CITY MANAGER TO EXECUTE THE AGREEMENT

**RECOMMENDED ACTION:** Approve the Third Amendment to the Agreement for City Attorney Services with Atchison, Barisone, Condotti & Kovacevich in the amount of \$133,560, and authorize the City Manager to execute the agreement.

**BACKGROUND:** In Fiscal Year 2001-2002, the City transitioned from an in-house staff City Attorney to a contract City Attorney with John G. Barisone from the law firm of Atchison, Barisone, Condotti & Kovacevich (Firm) for general and special legal services. The current contract will expire on June 30, 2013, and the Firm has proposed a one-year contract with no change in compensation from the Fiscal Year 2010-2011 amount.

**DISCUSSION:** The legal firm of Atchison, Barisone, Condotti & Kovacevich has been providing full-time City Attorney services since 2001. Mr. Barisone has submitted a contract proposal for a term of one-year at the same rates. In Fiscal Year 2008-2009, the contract amount was \$140,000 per year, but when the City implemented the furlough program which was a 4.6% salary reduction, the firm also accepted the 4.6% reduction, resulting in an amended contract in the amount of \$133,560. This contract incorporates the reduction from the previous contract. The retainer fee includes attendance at City Council meetings and other meetings as requested; office hours at City Hall; day-to-day legal work required by the various departments; assistance to the City Council; and participation in various training programs.

Additionally, the firm provides special legal services at a current rate of \$225 per hour for attorneys and \$85 per hour for paralegals. Special legal services are composed of: Litigation, arbitration, mediation or hearings commenced or defended by the City, civil or administrative municipal code enforcement, and criminal municipal code prosecutions. These services are provided only upon assignment by the City Council or City Manager.

**FISCAL IMPACT:** The ongoing fiscal impact would be \$133,560 per year for general legal services which is contained in the proposed FY13-14 Budget. Special litigation services are budgeted separately depending upon the anticipated litigation.

**ATTACHMENT:**

1. Third Amendment to Agreement for City Attorney Services.

Report Prepared By: Lisa G. Murphy  
Administrative Services Director

Reviewed and Forwarded  
by City Manager:

THIS PAGE INTENTIONALLY LEFT BLANK

THIS THIRD AMENDMENT TO AGREEMENT FOR CITY ATTORNEY SERVICES is made and entered into this first day of July, 2013, by and between the City of Capitola, on a municipal corporation, hereinafter referred to as "City" and Atchison, Barisone, Condotti & Kovacevich, a professional corporation, hereinafter referred to as "Law Firm" and is made with reference to, and will serve to amend, that certain agreement for legal services entered into on or about July 1, 2010, first amended on July 1, 2011 and amended a second time on July 1, 2012 between the City and Law Firm pursuant to which Law Firm agreed to provide legal services to the City for the 2010/2011 fiscal year (hereinafter referred to as the "2010/2011 Agreement").

NOW, THEREFORE, the parties agree as follows:

1. Paragraph 2 of the 2010/2011 Agreement as amended on July 1, 2011 and on July 1, 2012 is hereby amended to read as follows: "2.The term of this Agreement shall commence on July 1, 2013, and shall continue through June 30, 2014. Accordingly, the remaining term of this Agreement shall cover one fiscal year. For fiscal year 2013/2014, the annual compensation amounts and rates specified elsewhere in this Agreement shall remain in full force and effect."

2. Except as hereby expressly amended, all other terms and conditions of the Agreement shall remain in full force and effect.

IN WITNESS WHEREOF, the parties have executed this Third Amendment to the 2010/2011 Agreement for City Attorney Services the day and year first written above.

"CITY"

CITY OF CAPITOLA,  
a Municipal Corporation

"LAW FIRM"

ATCHISON, BARISONE,  
CONDOTTI & KOVACEVICH,  
a Professional Corporation

By: \_\_\_\_\_  
Jamie Goldstein, City Manager

By: \_\_\_\_\_  
John G. Barisone

THIS PAGE INTENTIONALLY LEFT BLANK



## CITY COUNCIL AGENDA REPORT

MEETING OF MAY 23, 2013

FROM: CITY MANAGER'S DEPARTMENT

SUBJECT: LIABILITY CLAIMS

---

**RECOMMENDED ACTION:** Deny liability claim and forward to the City's liability insurance carrier.

**DISCUSSION:**

The following claimant has filed a liability claim against the City of Capitola:

1. Dominique Townsend; \$172.17

**ATTACHMENTS:** None

Report Prepared By: Liz Nichols  
Executive Assistant to the City Manager

Reviewed and Forwarded  
by City Manager: 

THIS PAGE INTENTIONALLY LEFT BLANK



# CITY COUNCIL AGENDA REPORT

MEETING OF MAY 23, 2013

FROM: DEPARTMENT OF PUBLIC WORKS  
SUBJECT: FINAL APPROVAL OF LOCAL HAZARD MITIGATION PLAN

**RECOMMENDED ACTION:** Adopt a Resolution approving the City of Capitola Local Hazard Mitigation Plan.

**BACKGROUND:** At the December 12, 2012, City Council meeting the Council reviewed and conceptually approved the Draft Local Hazard Mitigation Plan (LHMP), and directed staff to submit the Draft Plan to Cal-EMA and FEMA for approval.

The review by Cal-EMA and FEMA is complete, and the City has received an approval letter from FEMA (Attachment 2). With this approval, the City can now complete the final adoption of the LHMP. The Resolution (Attachment 1) will become part of the Final LHMP.

**DISCUSSION:** The LHMP identifies critical facilities such as public buildings, transportation systems, emergency response communications networks, high potential loss facilities, hazardous material facilities, and important public resources which are vital to the City's response during a natural disaster or might be at risk during a disaster. The Plan also assesses Capitola's vulnerability to natural hazards, such as a coastal storm, flood, drought, coastal erosion, earthquake, landslide, etc. It then identifies mitigation actions to assist with making Capitola and our critical facilities more resilient during a natural disaster.

**FISCAL IMPACT:** Upon final adoption of the LHMP, the City will be eligible for State and Federal funding opportunities to implement projects that mitigate impacts identified in the report.

**ATTACHMENTS:**

1. Resolution
2. LHMP Approval Letter from FEMA
3. LHMP - Available at City Hall and on the City's website.

Report Prepared By: Steven Jesberg  
Public Works Director

Reviewed and Forwarded  
By City Manager:



THIS PAGE INTENTIONALLY LEFT BLANK

RESOLUTION NO. \_\_\_\_\_

**RESOLUTION ADOPTING A LOCAL HAZARD MITIGATION PLAN  
FOR THE CITY OF CAPITOLA**

**WHEREAS**, the Disaster Mitigation Act of 2000, as amended, requires that state and local governments, tribal nations and other eligible applicants develop and adopt hazard mitigation plans in order to receive certain federal assistance, and

**WHEREAS**, a Technical Advisory Committee (TAC) comprised of representatives from the City and partnering local agencies convened in order to study the risks from and vulnerabilities to natural hazards, and to make recommendations on mitigating the effects of such hazards to the City of Capitola; and

**WHEREAS**, a request for proposals was issued to hire an experienced consulting firm to work with the TAC to develop a comprehensive hazard mitigation plan for the City; and

**WHEREAS**, the efforts of the TAC members and the consulting firm, in consultation with members of the public, private, and non-profit sectors, have resulted in the development of a Local Hazard Mitigation Plan for the City of Capitola; and

**WHEREAS**, approval of the LHMP by FEMA in May 2013 constitutes formal completion of the plan, and established eligibility for the City to pursue hazard mitigation funds.

**NOW THEREFORE, BE IT RESOLVED** by the City Council of the City of Capitola, that the Hazard Mitigation Plan is hereby approved and adopted for the City of Capitola, in accordance with the Federal Disaster Mitigation Act of 2000.

**I HEREBY CERTIFY** that the above and foregoing Resolution was passed and adopted by the City Council of the City of Capitola at its regular meeting held on the 23<sup>rd</sup> day of May 2013, by the following vote:

- AYES:
- NOES:
- ABSENT:
- ABSTAIN:

\_\_\_\_\_  
Stephanie Harlan, Mayor

ATTEST:

\_\_\_\_\_, CMC  
Susan Sneddon, City Clerk

THIS PAGE INTENTIONALLY LEFT BLANK



FEMA

May 3, 2013

Steve Jesberg, Director  
Public Works Department  
420 Capitola Ave  
Capitola, California 95010

Dear Mr. Jesberg:

We have completed our review of the *City of Capitola Local Hazard Mitigation Plan* and have determined that this plan is eligible for final approval pending its adoption by the City of Capitola.

Formal adoption documentation must be submitted to the Regional office by the Jurisdiction within one calendar year of the date of this letter, or the entire plan must be updated and resubmitted for review. We will approve the plan upon receipt of the documentation of formal adoption.

If you have any questions regarding the planning or review processes, please contact Juliette Hayes, Community Planner at (510) 627-7211, or by email at [juliette.hayes@fema.dhs.gov](mailto:juliette.hayes@fema.dhs.gov).

Sincerely,

A handwritten signature in black ink, appearing to read "Sally Ziolkowski".

Sally Ziolkowski, Director  
Mitigation Division

cc: Kirby Everhart, California State Hazard Mitigation Officer  
Joanne Brandani, Cal EMA, Chief, Infrastructure Protection

THIS PAGE INTENTIONALLY LEFT BLANK



## CITY COUNCIL AGENDA REPORT

MEETING OF MAY 23, 2013

FROM: CITY MANAGER'S DEPARTMENT

SUBJECT: APPROVAL OF PROJECT AND AGREEMENT WITH KIM CHAVEZ FOR THE ESPLANADE KIOSK PUBLIC ART PROJECT IN AN AMOUNT NOT TO EXCEED \$15,000

**RECOMMENDED ACTION:** 1) Approve the proposed Esplanade Kiosk Public Art Project, 2) Authorize the City Manager to enter into an agreement with Kim Chavez in an amount not to exceed \$15,000 from the Public Art Fund, and 3) Approve Administrative Policy V-12, Use of Display Cases on the Village Esplanade Kiosk.

**BACKGROUND:** The Art & Cultural Commission prepared a concept for an artist designed kiosk in the Esplanade near the park. The kiosk would be used to promote events in the City, provide information from the City Council, Capitola Village, Wharf Business Improvement Area, Capitola-Soquel Chamber of Commerce, and will include an informational map of Capitola.

**DISCUSSION:** The project concept was approved by the City Council on September 27, 2012. Pursuit to the Capitola Municipal Code, an artist selection panel was convened. The panel consisted of Commission members, residents, and merchants from the Village. A "Call to Artists" went out to the local area as well as the Pacific Northwest last October with a description of the project. 19 artists submitted their proposals to the panel. The panel interviewed three artists, and selected Kim Chavez as the artist for this project.

The concept is a three-sided structure made from weather resistant stainless steel with a display case on each side. Mounted on top of the kiosk will be a bronze otter sculpture. The dimensions are: 32" wide at the top, 42" at the base, 88" high, including the otter sculpture. There will be the following wording on each side of the kiosk: "Capitola by the-Sea", "Welcome to our Village" and "Community Information".

The Planning Commission approved the project on May 2, 2013. The next step is for the City Council to approve the project and authorize the City Manager to enter into a contract with Ms. Chavez. The proposed timeline is to have the kiosk completed and in place by the end of July 2013. In addition, staff is recommending approval of a policy governing the use of the display cases on the kiosk. The policy provides that the cases are for use by the City, the Capitola BIA and the Chamber of Commerce. All information must relate to these entities and conform to the Municipal code. The City Manager's office will administer the policy.

**FISCAL IMPACT:** The proposed total project cost is \$15,000. The Public Art Fund has \$20,000 allocated in the Fiscal Year 2012/2013 Budget for Public Art Projects. The Public Art Fund is a restricted to only be used for public art projects.

**ATTACHMENTS:**

1. Proposed design
2. Contract
3. Administrative Policy

Report Prepared By: Lisa G. Murphy  
Administrative Services Director

Reviewed and Forwarded  
By City Manager: 

THIS PAGE INTENTIONALLY LEFT BLANK

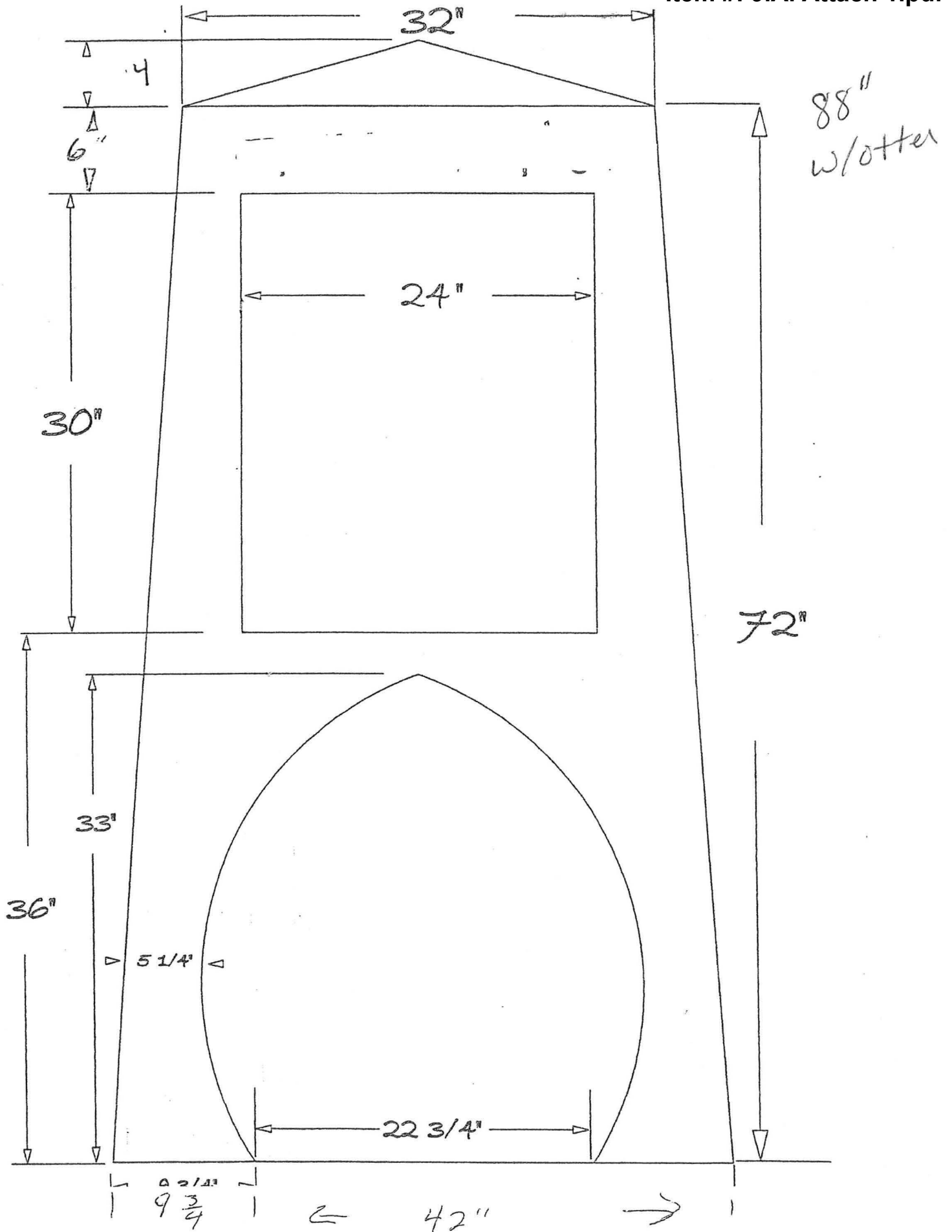



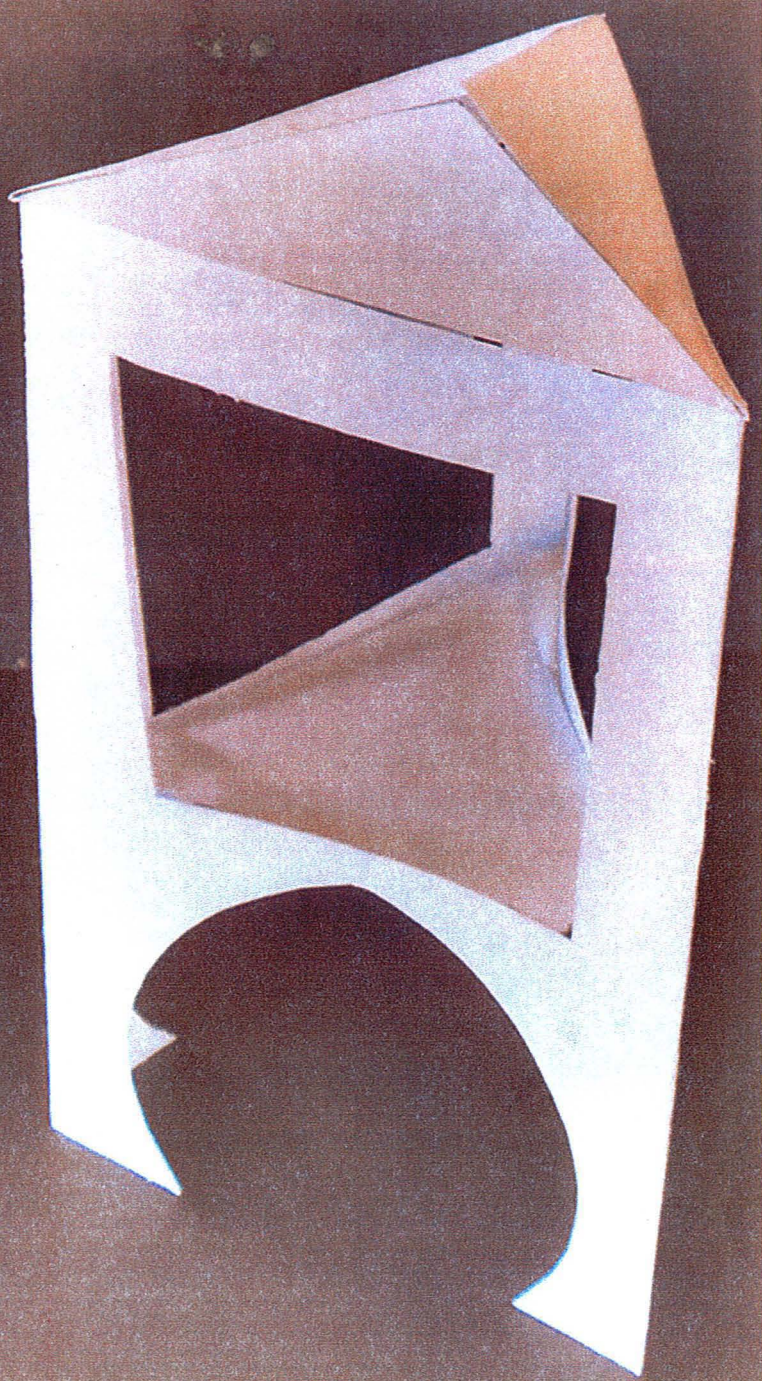
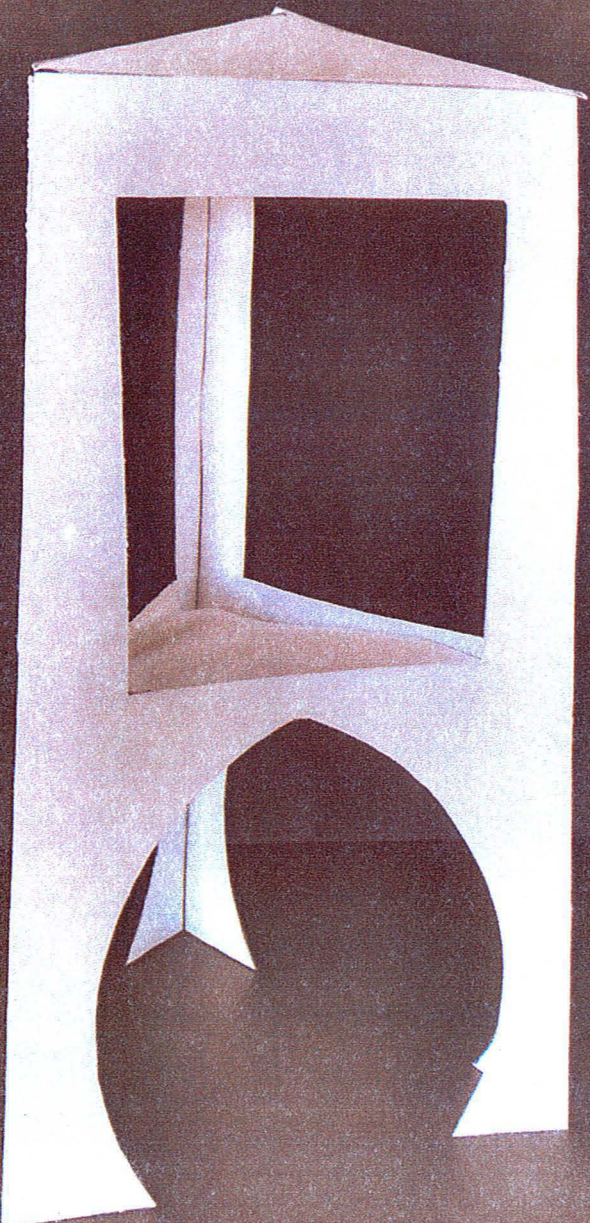



# Village Kiosk Project

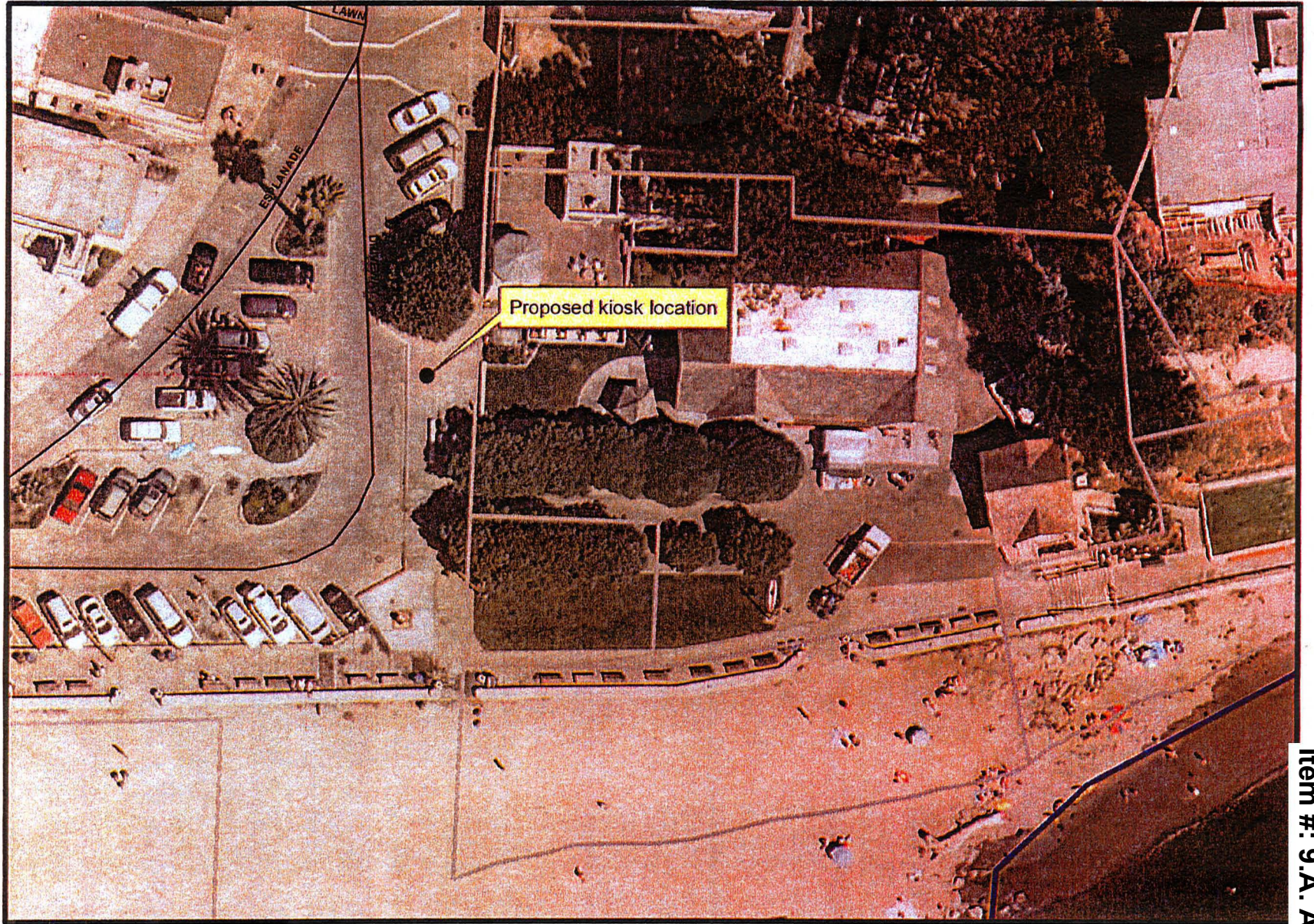

Proposed kiosk location

1 inch = 40 feet



Site Map



THIS PAGE INTENTIONALLY LEFT BLANK

## KIOSK/SCULPTURE ART AGREEMENT

This Kiosk/Sculpture Art Agreement (“Agreement”) is entered into this \_\_\_\_\_ day of \_\_\_\_\_, 2013 by and between the City of Capitola, California, a municipal corporation (“City”), and Kim Chavez (“Artist”).

### RECITALS

WHEREAS, the City has an interest in aesthetically enhancing that portion of the City commonly known as the Capitola Village through the placement and establishment of public art in the Capitola Village; and

WHEREAS, Artist is a highly regarded sculptor and fabricator known for the originality and quality of her sculptured works of art; and

WHEREAS, pursuant to a request for proposals issued by the City’s Art and Cultural Commission (“Commission”), Artist has proposed to sculpt for the City a bronze sea otter to be mounted on a stainless steel kiosk to be fabricated by Artist, hereinafter referred to in combination as the “Sculpture”, for the City’s display and use as public art at a location chosen by the City in the Capitola Village; and

WHEREAS, due to the Sculpture’s originality, beauty and strong subject matter connection to the Monterey Bay region with which the City of Capitola is so often identified, the City Council has accepted the Artist’s proposal and the City is agreeable to displaying the Sculpture on public property in the Capitola Village.

NOW, THEREFORE, in consideration of the following covenants, terms and conditions, the City and Artist agree as follows:

1. SCOPE OF SERVICES. The Artist agrees to design and fabricate the Sculpture in accordance with the previously approved concept design and specifications furnished to the Commission which is attached hereto as Exhibit “A”. Upon delivery of the Sculpture by Artist to the City, the City will install at its expense the Sculpture on a piece of public property selected by the City in the City’s Capitola Village.

2. TIME FOR PERFORMANCE. The Sculpture shall be completed and delivered to the City by the Artist on or before August 1, 2013. Upon timely delivery by Artist the Sculpture shall be installed in the Capitola Village by City on or before August 30, 2013.

3. COMPENSATION. The Artist shall receive compensation in the amount of Fifteen Thousand Dollars (\$15,000.00) to be paid as follows:

- (a) Seven Thousand Five Hundred Dollars (\$7500.00) upon execution of this Agreement.
- (b) Seven Thousand Five Hundred Dollars (\$7500.00) upon completion, delivery and acceptance of the Sculpture by the City.

4. COPYRIGHT. Except as provided herein, the Artist retains all reproduction rights under the Copyright Act of 1976, 17 U.S.C., Sections 101, et.seq. Since it is the intention of the

**Item #: 9.A. Attach 2.pdf**

parties that the Sculpture shall be unique, the Artist hereby agrees to limit the reproduction of the Otter to 20 or permit others to do so except by written permission of the City. The Artist hereby grants to the City and its assigns an irrevocable license to make photographs, drawings, or other two dimensional reproductions of the Sculpture without prior consent of the Artist, including but not limited to reproductions used in advertising, brochures, media publicity, promotional and tourist publications, noncommercial reproductions, in the City's portfolio of public art, and catalogues or other similar publications, provided that these rights are exercised in a reasonable manner.

5. GUARANTEE. The Artist does hereby guarantee that the Sculpture shall be free from any and all defects of any kind and nature in material, workmanship and fabrication, and the Artist shall provide the necessary materials and labor for, and shall bear any expenses in connection with repair of such defects of which the Artist is given written notice by the City within two years from the date of delivery. The Artist will not be responsible for damage resulting from fire, vandalism, acts of God or normal wear and tear attributable to weather.

6. ORIGINAL WORK. The Artist warrants that the Sculpture designed for City's purchase under this Agreement is a unique and original project of the Artist's creative efforts; and that it has not been nor will be accepted for sale or installed elsewhere.

7. INDEMNIFICATION. Each party agrees to defend, indemnify, and save the other party harmless from any and all claims, liability, losses, expenses, attorneys' fees or costs arising out of said party's or said party's employees', officers' or agents' negligent acts, errors, omissions or willful misconduct while performing their obligations pursuant to this Agreement, but only in proportion to and to the extent such liability, losses, expenses, attorneys' fees, costs or claims for injury or damages are caused by the negligent or intentional acts or omissions of said party, their employees, officers, or agents.

8. INSURANCE. The Artist, as of the date of this Agreement, at the Artist's sole cost and expense, shall obtain, furnish and maintain in full force and effect a liability insurance policy to protect the City against any and all claims for personal and property injury, including death, arising from or in connection with the performance of the services hereunder by Artist, its agents, representatives, employees or subcontractors in the amount of Five Hundred Thousand Dollars (\$500,000.00) per occurrence. The insurance policy shall remain in effect until after said work of art is accepted and installed by the City and shall name the City and its officials and employees as additionally insured. A certificate of insurance shall be provided to the City verifying the required insurance coverage.

9. COMPLIANCE WITH LAWS. The Artist shall comply with all applicable laws and ordinances of the State of California and the City.

10. SUBCONTRACTING & ASSIGNMENT. If any part of the subject sculpting or fabrication is to be done through the use of subcontractors, the City must first approve the use of any subcontractor in writing. The City shall not unreasonably withhold the approval of any qualified subcontractor. The Artist shall not assign this Agreement without the prior written consent of the City.

11. CHANGES. All changes to this Agreement shall require a written agreement signed by all parties prior to any change.

12. TERMINATION. The City may, by written notice to the Artist, terminate this Agreement in whole or in part at any time, either for the City's convenience or because of the failure of the Artist to fulfill her contractual obligations. If termination is for the convenience of the City, the Artist shall be entitled to the full Fifteen Thousand Dollars (\$15,000.00) less an amount equal to expenses anticipated to be incurred by the Artist at the time of execution of this Agreement but not yet incurred at the time of such termination.

If termination of the Agreement is due to failure of the Artist to fulfill the Artist's contract obligations, the Artist shall remit to the City a sum equal to all payments made by City pursuant to this Agreement prior to termination.

If the Artist terminates this Agreement due to death or an incapacity which prevents the Artist from completing the project, all materials purchased for the Sculpture shall become the property of the City. The Artist or her representative shall provide the City with comprehensive models and plans which will enable the City to complete the Sculpture. The Artist shall not be entitled to further compensation but shall not be required to refund to the City funds previously paid to the Artist.

13. REMOVAL OR DISASSEMBLAGE. The Artist understands and agrees that the Sculpture will be owned by the City. As such, at any time in the future the City in its sole and absolute discretion, may move the Sculpture to another location or disassemble it. Should City so elect, the City assumes full responsibility for the moving and reserves the right to reinstall the Sculpture at a different site, or to dispose of the Sculpture as the City deems appropriate. Such a determination is the sole right of the City. However, the City will attempt to contact the Artist to obtain the Artist's views regarding relocation or disposition of the Sculpture.

14. DISPUTES. This Agreement is governed by the laws of the State of California and all actions shall be brought in court in Santa Cruz County, California.

15. ENTIRE AGREEMENT. This Agreement contains the entire agreement between the parties hereto, and they shall not be bound by any terms, conditions, statements, warranties or representations, oral or written, not herein stated.

Dated: \_\_\_\_\_ CITY OF CAPITOLA, a municipal corporation

By \_\_\_\_\_  
Jamie Goldstein, City Manager

Approved As To Form:

\_\_\_\_\_  
City Attorney

Dated: \_\_\_\_\_ ARTIST

By \_\_\_\_\_

EXHIBIT A

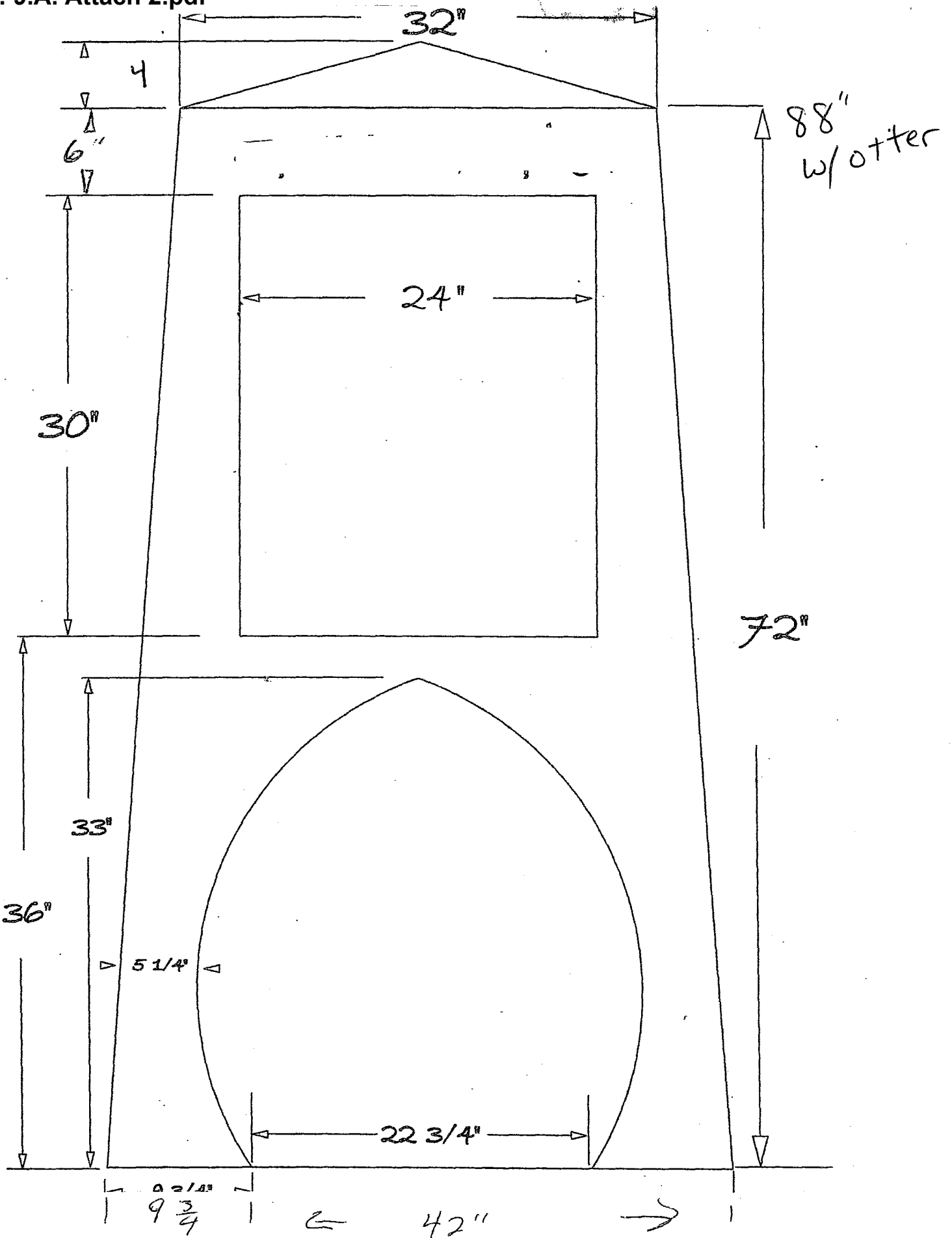

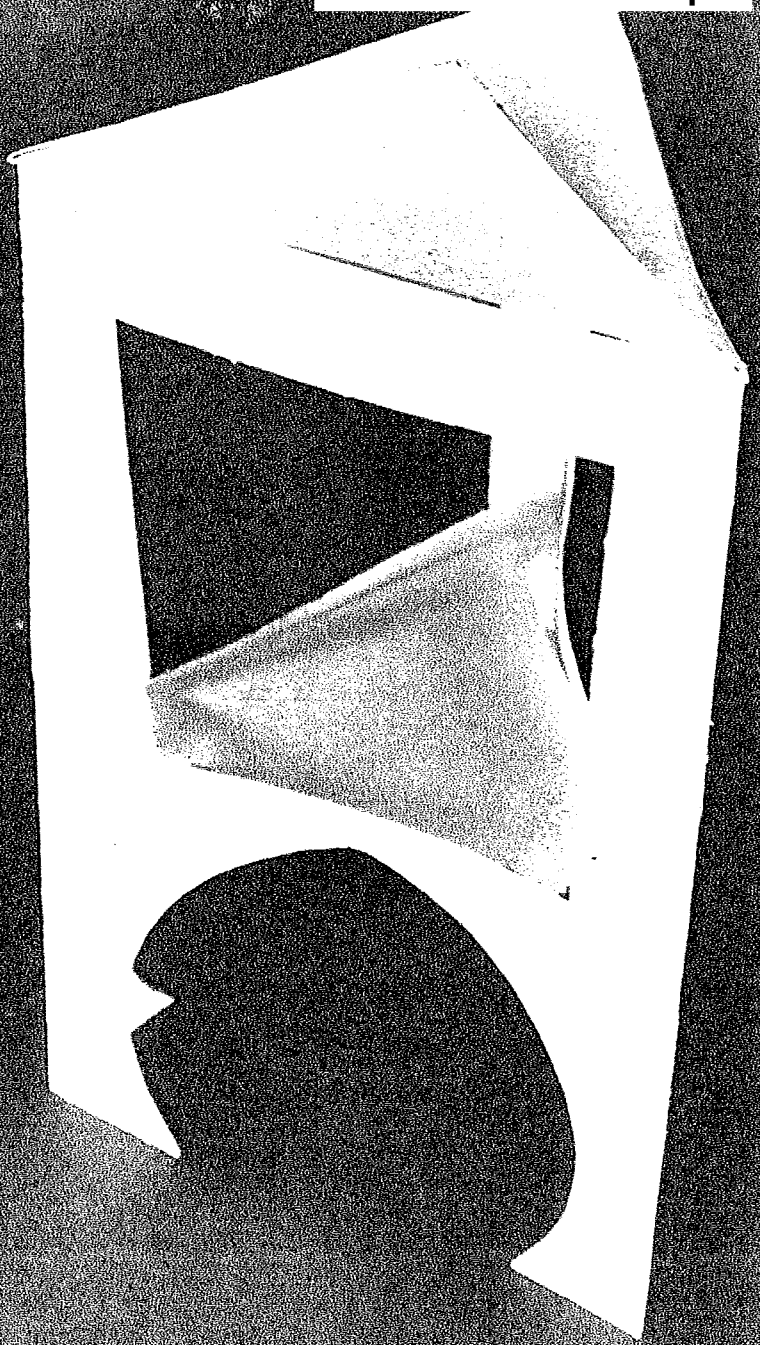
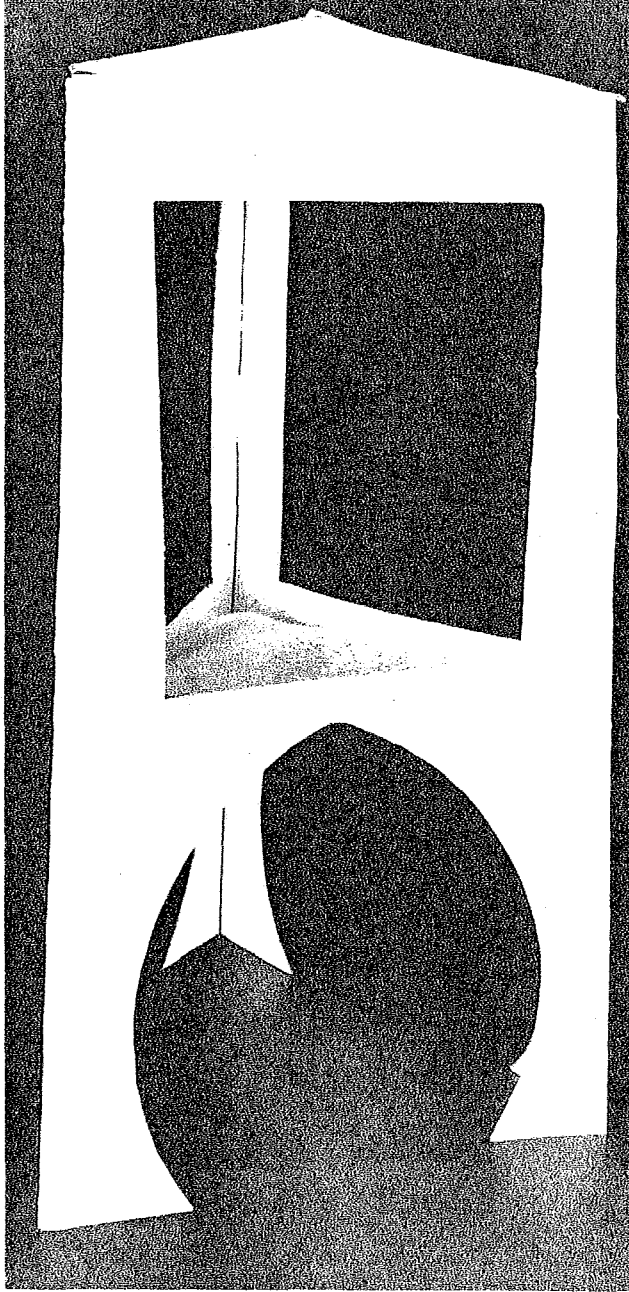



THIS PAGE INTENTIONALLY LEFT BLANK



## ADMINISTRATIVE POLICY

Number: V-12  
 Issued: 05/23/13  
 Jurisdiction: City Council

**Use of Display Cases on the  
 Village Esplanade Kiosk**

**I. PURPOSE**

To establish a policy and procedure for the use of the three display cases on the kiosk located in the Village Esplanade.

**II. POLICY**

The display cases on the Village Kiosk are primarily for the use of the City of Capitola, the Capitola Village Business Improvement Association, and the Capitola-Soquel Chamber of Commerce, collectively known as Capitola Entities for the purpose of providing information about member businesses and City events, with the exception noted below. In case of any dispute on the use of space the City Manager shall be the final authority. All information must relate directly to the Capitola Entities, shall be in conformance with the Capitola City Municipal Codes and shall be approved by the City Manager's office. The City shall be responsible for the development, maintenance, and updating of the material in this case, including all associated costs. All material in the cases which list dated activities will be removed within 48 hours after the event has occurred.

From time to time, the City Manager may notify the Entities of the need to use all three display cases. The City Managers office will provide notice 10 working days in advance. Once the City's needs are complete the businesses may resume utilizing the entire display case.

Any use of the display cases other than designated above must first be approved by the City Manager.

To receive approval for display, a written request must be submitted at least 10 days prior to display, and all items recommended in the request for display must be identified and specifically described.

**III. RESPONSIBILITY**

The City Mangers office shall be responsible for implementation of this policy.

This Policy is Approved and Authorized by:

\_\_\_\_\_  
 Jamie Goldstein  
 City Manager

JG/lgm

THIS PAGE INTENTIONALLY LEFT BLANK



## CITY COUNCIL AGENDA REPORT

MEETING OF MAY 23, 2013

FROM: DEPARTMENT OF PUBLIC WORKS

SUBJECT: CONSIDERATION OF AUTHORIZING THE SALE OF A PORTION CITY-OWNED PROPERTY LOCATED AT MCGREGOR DRIVE (APN 036-341-02) TO THE SOQUEL CREEK WATER DISTRICT

**RECOMMENDED ACTION:** Approve the purchase agreement with Soquel Creek Water District for a portion of City-owned property located on McGregor Drive (APN: 036-341-02).

**BACKGROUND:** In January 2012 the City entered into an Option to Purchase Agreement (Purchase Agreement) with the Soquel Creek Water District to sell a portion of the McGregor Property to facilitate construction of a District pump station on the property.

Prior to entering in the Purchase Agreement the City issued a notice pursuant to Government Code Section 54222 in October 2011, notifying prescribed public agencies of their right to purchase the property. No other agencies filed the required Notice of Intent to Purchase within 60 days.

**DISCUSSION:** The original Purchase Agreement described a 9900 square foot portion along the western boundary of the larger 187,308 square foot McGregor Property. Following subsequent studies and environmental review the square footage being purchased was reduced to 7110. The final terms of the deal are as follows:

- The purchase price has been set at \$100,000 and after subtracting \$2,000 in credit from the purchase options, the final amount due to the City is \$98,000.
- The lot size is 7,110 sq-ft with dimensions of 79-ft x 90-ft. Survey and geotechnical investigations are complete and the legal description has been prepared by Ifland Survey.
- City may utilize 1.051 acre feet of Water Demand Offset Credits (WDO credits) acquired in connection with the Senior Housing Project on Bay Avenue, on another public building or park project of the City of Capitola providing that such WDO credits are utilized for such purposes within ten (10) years from the date of this agreement.
- City is granted the option for ten (10) years to purchase, at the cost of \$18,000 per acre foot, up to three (3) acre feet of offset credit based on the actual offset requirement for a City Park to be developed on the parcel adjacent to that conveyed herein, subject to the District's policies on new connections at the time of service application.
- City is granted the ability to transfer or sell WDO credits in the amount of 5.88 acre feet from the previously occupied Pacific Cove Mobile Home Park (PCMHP). The District will administer the transfer or sale of WDO credits and limit the sale price to the price the District is currently selling credits for, not less than \$18,000 per acre foot.

An escrow account has been opened and with approval of the purchase agreement by both agencies it is anticipated that the transaction will be finalized within 30 days.

**FISCAL IMPACT:** Revenue from this sale was included in the current year budget.

**ATTACHMENTS:**

1. Purchase Agreement

Report Prepared By: Steven Jesberg  
Public Works Director

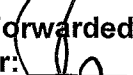
Reviewed and Forwarded  
By City Manager: 

THIS PAGE INTENTIONALLY LEFT BLANK

## Purchase Agreement

The parties to this Purchase Agreement are the City of Capitola (hereinafter referred to as Seller) and the Soquel Creek Water District, a County Water District (hereinafter referred to as Buyer).

### RECITALS

A. Seller is the owner of a vacant parcel of land commonly known as Santa Cruz County Assessors Parcel Number 036-341-02.

B. Buyer is a County Water District, created pursuant to the provisions of the California Water Code Sections 30,000 et. seq.

C. Buyer is purchasing a portion of the property owned by Seller for potential future water facilities in connection with its provision of water. The portion to be purchased is an irregular portion in the Northwest corner of the property adjoining McGregor Drive and is depicted generally on Exhibit A and legally described in Exhibit B, attached hereto.

D. Seller granted an option to purchase said property to Buyer which expired on September 15, 2012. Said Option was extended until March 15, 2013.

E. Buyer furnished to Seller the sum of Two Thousand Dollars (\$2,000) as an option payment, which shall be credited to the purchase price.

NOW THEREFORE, it is hereby agreed:

1. CONSIDERATION. Seller hereby agrees to a cash purchase price of One Hundred Thousand Dollars (\$100,000) pursuant to the independent appraisal of May & Associates which has been furnished to Seller. Additional consideration is provided in Paragraph 7 below.

2. CREDIT. Seller grants Buyer a credit of Two Thousand Dollars (\$2,000) previously paid through the original purchase option and the extension to the purchase option. Credit is applied to the cash purchase price, reducing the total amount due to Seller to Ninety Eight Thousand Dollars (\$98,000).

3. HOLD HARMLESS AND INDEMNIFICATION. Buyer agrees that during the purchase period, Buyer will hold Seller harmless from, defend and indemnify Seller from any and all claims for personal injury or property damage arising from Buyer or any of Buyer's employees or agents activities on the property during the option period.

4. ESCROW. Buyer, upon execution of this Purchase Agreement, shall open an escrow at a title and escrow company of Buyer's choosing in Santa Cruz County for purposes of obtaining a preliminary title report. Upon execution of this Purchase Agreement, Buyer shall deposit in escrow the balance of the purchase price of Ninety Eight Thousand Dollars (\$98,000). All costs of escrow and title insurance shall be borne by Buyer.

5. PRORATIONS. All property taxes, insurance and rents (if any) shall be prorated as of the close of escrow.

6. CLOSE OF ESCROW. Upon deposit of the balance of the purchase price and Seller being able to convey clear and marketable title, including compliance with Government Code Section 65402, escrow shall close within 45 days of the execution of this Purchase Agreement. Time is of the essence of this agreement

7. ADDITIONAL CONSIDERATION: If this Purchase Agreement provided for herein is executed, then as and for additional consideration for the purchase herein

provided;

7(A). Buyer agrees that Seller may utilize its unused Water Demand Offset Credits (WDO Credits) being 1.051 acre feet, acquired in connection with the Senior Housing Project on Bay Avenue, on another public building or park project of the City of Capitola providing that such WDO Credits are utilized for such purposes within ten (10) years from the date of this agreement and are subject to any other restrictions applicable to WDO Credits and water service existing at the time of use. If the WDO Credits are not used within the ten (10) year period, those credits shall be applicable indefinitely toward offset requirements of affordable housing portions of projects at the discretion of the City; however, the District will not provide any reimbursement or otherwise assume any liability for completed retrofits that are not credited to an eligible development or are no longer required as a condition for receiving water service in accordance with District Resolution No. 06-18.

7(B). Additionally, the Buyer (City) is granted the option for ten (10) years from the date of this agreement to purchase at the cost of \$18,000 per acre foot up to three (3) acre feet of offset credit based on the actual offset requirement for a City Park to be developed on the parcel adjacent to that conveyed herein, subject to the District's policies on new connections at the time of service application. If this option for purchase of additional WDO Credits is not exercised within the ten (10) year period, this option shall expire.

7(C). Additionally, the Seller (City) is granted the ability to transfer or sell WDO Credits in the amount of 5.88 acre feet from the previously occupied Pacific Cove Mobile Home Park. Said 5.88 acre feet of WDO Credits may be transferred or sold to a non-City project on a different site than the Pacific Cove Mobile Home Park. The Seller and Buyer



**Item #: 9.B. Attach 1.pdf**

agree that the Buyer will administer the transfer or sale of WDO Credits and the sale price is limited to the price the District is currently selling credits for, not less than \$18,000 per acre foot. The District will not provide any reimbursement or otherwise assume any liability for credits not transferred or sold if WDO offsets are no longer required as a condition for receiving water service in accordance with District Resolution No. 06-18.

8. **BINDING EFFECT.** This agreement is binding upon the parties, their heirs, successors and assigns and shall survive close of escrow.

9. **ATTORNEYS FEES.** If an action is brought to enforce, avoid or interpret this agreement on any grounds, the prevailing party shall be entitled to reasonable attorneys fees and all costs incurred.

10. **CERTIFICATE OF COMPLIANCE.** If required by the County of Santa Cruz, Buyer agrees to obtain for Seller a certificate of compliance from the City of Capitola affirming that the balance of the parcel, not acquired by Buyer, is a legal parcel.

11. **CALIFORNIA ENVIRONMENTAL QUALITY ACT.** The District is the lead agency for purposes of the California Environmental Quality Act. Both the District and City have jointly review the environmental documents and District adopted Resolution No. 13-05 adopting the McGregor Drive Pump Station Project Initial Study/Mitigated Negative Declaration and approved the Mitigation Monitoring and Reporting Program for the McGregor Drive Pump Station Project located on McGregor Drive in Capitola, APN 036-341-02, CWO 08-004 on February 5, 2013.

12. **FEES.** District agrees to pay any fees to the City for any amounts which would be normally charged for a Coastal Development Permit or the Certificate of

Compliance.

13. COMPLIANCE WITH GOVERNMENT CODE SECTION 65402. Following approval of the environmental documents, the City shall undertake the steps necessary to comply with the requirements of California Government Code Section 65402 for disposal of publicly owned property.

Dated: May \_\_\_, 2013

Soquel Creek Water District

\_\_\_\_\_  
Authorized Official

BUYER

Dated: May \_\_\_, 2013

City of Capitola

\_\_\_\_\_  
Authorized Official

SELLER

Approved as to form:  
Bosso Williams  
A Professional Corporation

\_\_\_\_\_  
District Counsel

Atchison, Barisone, Condotti & Kovacevich

\_\_\_\_\_  
City Attorney



# IFLAND SURVEY

Surveying - Mapping - GPS

303 Potrero Street, Suite 43-108, Santa Cruz, CA 95060  
Tel 831.426.7941 Fax 831.426.6266

JOB NO. \_\_\_\_\_ G11008  
SHEET NO. \_\_\_\_\_ 1 \_\_\_\_\_ OF \_\_\_\_\_ 1 \_\_\_\_\_  
CALCULATED BY \_\_\_\_\_ jlb \_\_\_\_\_ DATE \_\_\_\_\_ 04/09/12  
SCALE: \_\_\_\_\_ 1"=20'

## Exhibit A

CA STATE HWY. NO.1  
(CalTrans Right-of-Way Record Map R-44B.3)

R=1620.00

McGregor Drive  
RELINQUISHMENT PARCEL 2 (1679 OR 344)

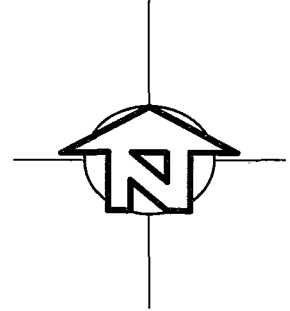

S79°40'53"W  
92.87'

TERMINUS OF  
COURSE (44)  
1679 OR 344

CITY OF CAPITOLA PROPERTY LINE  
S79°40'53"W  
79.00'

S79°40'53"W  
132.91'

POINT OF  
BEGINNING

N09°46'23"W  
90.00'

PORTION APN 036-341-02

7,110 SQUARE FEET  
0.16 ACRES

STATE OF CALIFORNIA  
FORMER LANDS OF  
CALIFORNIA PACIFIC TITLE COMPANY  
1292 OR 307  
APN 036-341-01

S09°46'23"E  
90.00'

79.00'  
N79°40'53"E

APN 036-341-02

# Exhibit B

## LEGAL DESCRIPTION

SITUATE in the State of California, County of Santa Cruz, and described as follows:

BEGINNING at a point on the southerly line of Parcel 2 in the deed conveyed to the County of Santa Cruz, recorded March 5, 1965 in Book 1679 at Page 344, Official Records of Santa Cruz County, as the same parcel is shown as "Relinquishment Parcel 2" on the California Department of Transportation Right-of-Way Record Map R-44B.3, and from which the terminus of course (44) as described in the above mentioned deed bears North 79° 40' 53" East, 171.87, and from which the northeasterly corner of the parcel of land conveyed to California Pacific Title Company by deed recorded January 5, 1960 in Book 1292 at Page 307, Official Records of Santa Cruz County, bears North 09° 46' 23" West, 85.40 feet; thence along the easterly line of said lands conveyed to California Pacific Title Company South 09° 46' 23" East, 90.00 feet; thence leaving said easterly line and parallel to said southerly line of Parcel 2, North 79° 40' 53" East, 79.00 feet; thence parallel to said easterly line, North 09° 46' 23" West, 90.00 feet to said southerly line (now McGregor Drive); thence along said southerly line of Parcel 2, South 79° 40' 53" West, 79.00 feet to the POINT OF BEGINNING.

and CONTAINING 7,110 square feet.

END OF DESCRIPTION



Portion of APN 036-341-02

THIS PAGE INTENTIONALLY LEFT BLANK



# CITY COUNCIL AGENDA REPORT

## MEETING OF MAY 23, 2013

FROM: CITY MANAGER  
SUBJECT: FORMATION OF THE 2<sup>nd</sup> SANTA CRUZ COUNTY TOURISM MARKETING DISTRICT 2013

**RECOMMENDED ACTION:** Adopt a Resolution granting consent to the County of Santa Cruz to form the Second Santa Cruz County Tourism Marketing District 2013 (TMD2).

**BACKGROUND:** The Tourism Marketing District (TMD) was established in 2010, with boundaries contiguous to the County of Santa Cruz, including the four cities. The TMD is a benefit assessment district to help fund marketing and sales promotion efforts for Santa Cruz County lodging businesses. The establishment of the TMD has significantly expanded the exposure of Santa Cruz County tourist lodging opportunities. In 2011, Santa Cruz County experienced an 11.8% increase in hotel occupancy rates, including significant increases in the fall shoulder season where TMD efforts funded significant new promotions.

In November 2012 voters approved Transient Occupancy Tax (TOT) ballot measures in both the County and the City of Santa Cruz. As part of a compromise reached with the Lodging Association, those entities agreed to limit the TOT increase to 1%, provided the Santa Cruz County Conference and Visitors Council (CVC) would, as of the end of 2012-13 fiscal year, no longer request an annual public contribution. As part of that plan, the lodging industry would seek an increase to the Tourism Marketing District fee to offset the loss of public funding. The City has not received a funding request from the CVC for the 2013/14 fiscal year.

In response to the industry comments received on a proposed modification of the TMD, it was determined the establishment of a second TMD should instead be considered to address the funding needs of the CVC.

**DISCUSSION:** The benefit assessment district must be formed pursuant to the Property and Business Improvement District Law of 1994 which requires legislative action to levy a new assessment. The County of Santa Cruz Board of Supervisors will conduct the legislative process. The consent of the Capitola City Council is required to form the district within the City's territorial jurisdiction. The consent of the other cities is also being requested.

The attached report provides detailed information on the proposed benefit assessment district, including the formation process, assessment rate, duration, costs, budget, and services. In summary, the TMD2 is proposed to be established countywide, including all cities and unincorporated areas, and would have two-year duration. The primary goal of the TMD2 is to increase room occupancy which would in turn increase TOT revenues to local jurisdictions. In addition, the TMD2 would provide a stable source of funding for tourism promotion. The funding generated by the benefit assessment district (estimated at \$400,000 annually) would supplement existing private and public tourism promotion funding.

**FISCAL IMPACT:** Each jurisdiction would collect the assessment from subject properties within its territory along with the existing TOT. The City will be paid a fixed administrative fee of 1% of the amount collected within their jurisdiction for the costs of administration, which is an estimate of the costs of services to be delivered by the cities. In the event there are unanticipated actual additional costs beyond the administrative fee, the cities will be paid any actual costs.

The expanded marketing and sales promotion is expected to increase room occupancy, which in turn will result in an increase in TOT revenue for the City.

### **ATTACHMENTS:**

1. Resolution
2. City of Santa Cruz May 14, 2013, Staff Report

Report Prepared By: Jamie Goldstein, City Manager  
City Manager

Reviewed and Forwarded  
By City Manager: 

THIS PAGE INTENTIONALLY LEFT BLANK

RESOLUTION NO. \_\_\_\_

**RESOLUTION OF THE CITY COUNCIL OF THE CITY OF CAPITOLA,  
STATE OF CALIFORNIA, GRANTING CONSENT TO THE COUNTY OF  
SANTA CRUZ TO FORM THE SECOND SANTA CRUZ COUNTY TOURISM  
MARKETING DISTRICT (TMD2)**

**WHEREAS**, the County of Santa Cruz is beginning the process to form a Santa Cruz County Second Tourism Marketing District (TMD2) pursuant to the Property and Business Improvement District Law of 1994, Streets and Highways Code Section 36600 et seq., to promote tourism and the lodging businesses in Santa Cruz County; and

**WHEREAS**, the County of Santa Cruz Board of Supervisors will conduct the legislative process, including the notice, protest, and public hearing procedures to establish the TMD2; and

**WHEREAS**, the consent of the Capitola City Council is required to form the District within the City's territorial jurisdiction. The consent of the cities of Scotts Valley, Capitola, and Watsonville is also being requested; and

**NOW, THEREFORE, BE IT HEREBY RESOLVED** by the City Council of the City of Capitola, as follows:

Section 1: The above recitals are true and correct.

Section 2: The City Council consents to the County of Santa Cruz forming the TMD2, which District shall include the City of Capitola.

Section 3: The District Plan shall allow the City to be reimbursed for actual administrative costs associated with collection of the assessment.

Section 4: The City Clerk of the City of Capitola is hereby directed to transmit a certified copy of this Resolution to the Clerk of the County of Santa Cruz Board of Supervisors.

Section 5: This Resolution is effective upon its adoption.

**I HEREBY CERTIFY** that the above and foregoing resolution was passed and adopted by the City Council of the City of Capitola at its regular meeting held on the 23<sup>rd</sup> day of May, 2013, by the following vote:

AYES:  
NOES:  
ABSENT:  
ABSTAIN:

\_\_\_\_\_  
Stephanie Harlan, Mayor

ATTEST:

\_\_\_\_\_, CMC  
Susan Sneddon, City Clerk



THIS PAGE INTENTIONALLY LEFT BLANK



## CITY COUNCIL AGENDA REPORT

DATE: 5/7/2013

AGENDA OF: 5/14/2013

DEPARTMENT: City Clerk

SUBJECT: Formation of the Second Santa Cruz County Tourism Marketing District 2013 (CN)

**RECOMMENDATION:** Resolution granting consent to the County of Santa Cruz to form the Second Santa Cruz County Tourism Marketing District 2013 (TMD2).

**BACKGROUND:** The Tourism Marketing District (TMD) was established on June 15, 2010, with boundaries contiguous to the County of Santa Cruz, including the four cities. The TMD is a benefit assessment district to help fund marketing and sales promotion efforts for Santa Cruz County lodging businesses. The establishment of the TMD has significantly expanded the exposure of Santa Cruz County tourist lodging opportunities, allowing for a stronger market presence within those primary markets that drive the tourism lodging business in our County as well as expanding into longer-term customer development efforts beyond our typical markets. In 2011 Santa Cruz County experienced an 11.8% increase in hotel occupancy rates, including significant increases in the fall shoulder season where TMD efforts funded significant new promotions.

In November 2012 voters approved Transient Occupancy Tax (TOT) ballot measures (Measure N (Unincorporated County) and Q (City)) increasing TOT rate to eleven percent, effective July 1. Councilmembers will recall that originally a 12% rate was proposed but only an 11 % level was acceptable and supportable by the lodging industry, and the 11% rate became part of a larger industry proposal, as follows:

- The rate for the TOT in the unincorporated area and the City of Santa Cruz would be proposed to the voters to be 11%;
- The rate increase would become effective as of July 1, 2013;
- The Santa Cruz County Conference and Visitors Council (CVC) would, as of the end of the 2012-13 fiscal year, no longer request an annual contribution from the City of Santa Cruz or the County; and
- The lodging industry would seek an increase to the Tourism Marketing District (TMD) fee; the CVC would continue to administer the TMD on behalf of the lodging industry, and the CVC would continue to perform services for local jurisdictions using the new funding stream.

**Item #: 9.C. Attach 2.pdf**

In response to the industry comments received on a proposed modification of the TMD, it was determined that the establishment of a second TMD should instead be considered to address the funding needs of the CVC.

**DISCUSSION:** The benefit assessment district must be formed pursuant to the Property and Business Improvement District Law of 1994 which requires legislative action to levy a new assessment. The County of Santa Cruz Board of Supervisors will conduct the legislative process, including the notice, protest, and public hearing procedures to establish the TMD2. The consent of the Santa Cruz City Council is required to form the district within the City's territorial jurisdiction. The consent of the cities of Scotts Valley, Capitola, and Watsonville is also being requested.

The attached report provides detailed information on the proposed benefit assessment district, including the formation process, assessment rate, duration, costs, budget, and services. In summary, the TMD2 is proposed to be established countywide, including all cities and unincorporated areas, and would have two-year duration. The primary goal of the TMD2 is to increase room occupancy which would in turn increase TOT revenues to local jurisdictions. In addition, the TMD2 would provide a stable source of funding for tourism promotion. The funding generated by the benefit assessment district (estimated at \$400,000 annually) would supplement existing private and public tourism promotion funding.

**FISCAL IMPACT:** It is proposed that each jurisdiction would collect the assessment from subject properties within its territory along with the existing TOT. The County of Santa Cruz and each city will be paid a fixed administrative fee of 1% of the amount collected within their jurisdiction for the costs of administration, which is an estimate of the costs of services to be delivered by the jurisdictions. In the event that there are unanticipated actual additional costs beyond the administrative fee, the jurisdictions will be paid any actual costs which exceed the fixed fee mentioned above provided that the jurisdiction makes available to the Santa Cruz County Conference and Visitors Council a full itemization of the actual costs.

The expanded marketing and sales promotion is expected to increase room occupancy, which in turn will result in an increase in TOT revenue for the City.

Submitted by:  
Cynthia Mathews  
City Councilmember

Submitted by:  
Martin Bernal  
City Manager

**ATTACHMENTS:**  
Santa Cruz County Tourism Marketing District 2013 Management District Plan  
Resolution



# County of Santa Cruz

0633

## COUNTY ADMINISTRATIVE OFFICE

701 OCEAN STREET, SUITE 520, SANTA CRUZ, CA 95080-4073

(831) 454-2100 FAX: (831) 454-3420 TDD: (831) 454-2123

SUSAN MAURIELLO, J.D., COUNTY ADMINISTRATIVE OFFICER

AGENDA: May 14, 2013

April 25, 2013

### BOARD OF SUPERVISORS

County of Santa Cruz

701 Ocean Street

Santa Cruz, CA 95060

### INTENTION TO ESTABLISH A SECOND TOURISM MARKETING DISTRICT

Dear Members of the Board:

The purpose of this letter is to seek your Board's approval to initiate the process to establish a second Tourism Marketing District, with boundaries contiguous to the County of Santa Cruz, including the four cities. The purpose of such a district is to provide supplemental funding for tourism promotion benefitting lodging businesses. The funding will ensure that adequate financing exists for the investment required to increase occupancy in the lodging industry and be competitive in the group and leisure tourism market. The investment will cover an expanded marketing and promotional budget needed to reach this market segment.

#### Background

The Tourism Marketing District (TMD) was established on June 15, 2010, with boundaries contiguous to the County of Santa Cruz, including the four cities. Annual assessment rates implemented at the adoption of the TMD were \$1.00 per occupied room per night for lodging business with between six (6) and twenty-nine (29) units and \$1.50 per occupied unit per night on lodging business with thirty (30) or more units. Lodging businesses with less than six (6) units were exempt from the assessment. The District was initially formed for a period of five years, subject to an annual approval of the District Plan by the Board. The District can be renewed for a new term of up to ten years.

The establishment of the TMD has significantly expanded the exposure of Santa Cruz County tourist lodging opportunities, allowing for a stronger market presence within those primary markets that drive the tourism lodging business in our County as well as expanding into longer-term customer development efforts beyond our typical markets. In 2011 Santa Cruz County experienced an 11.8% increase in hotel occupancy rates, including significant increases in the fall shoulder season where TMD efforts funded significant new promotions.

On January 8, 2013, your Board adopted an ordinance amending Section 4.24.030 of the Santa Cruz County Code by increasing the transient occupancy tax rate from nine and one-half of one percent to eleven percent, effective July 1, 2013. Board members will recall that originally a 12% rate was proposed but only an 11 % level was supported by the lodging industry, and the 11% rate became part of a larger industry proposal, as follows:

48

Board of Supervisors  
 Agenda: May 14, 2013  
 Page 2

- The rate increase for the TOT in the unincorporated area and the City of Santa Cruz would be capped at 11 %;
- The rate increase would become effective as of July 1, 2013;
- The Santa Cruz County Conference and Visitors Council (CVC) would, as of the end of the 2012-13 fiscal year, no longer request an annual contribution from the City of Santa Cruz or the County; and
- The lodging industry would seek an increase to the Tourism Marketing District (TMD) fee; the CVC would continue to administer the TMD on behalf of the lodging industry, and the CVC would continue to perform services for local jurisdictions using the new funding stream.

As your Board is aware, a proposal to modify the assessments levied by the current TMD had already been initiated. The proposed modifications were first considered at a public meeting held on April 9, 2013, and a further public hearing to consider the changes was scheduled for today. In response to the initial public comments received and after continued discussions with representatives of the CVC regarding the proposed changes, it was determined that the establishment of a second TMD should instead be considered to address the funding needs of the CVC. As part of staff's recommendation that a second TMD be established, staff also recommends that the modification process for the existing TMD be abandoned.

#### Formation of a Tourism Business Improvement or Marketing District

In California, tourism marketing districts are formed pursuant to the Property and Business Improvement District Law of 1994. This law allows for the creation of a special benefit assessment district to raise funds within a specific geographic area. The formation of such a district is subject to a veto by written protest from a "proportional majority" of affected parties. Such a majority would be comprised of the total number of affected lodging business owners who would pay fifty percent (50%) or more of the proposed assessment. This protest opportunity is available once each year for the life of the District.

The resolution and notice of public hearing before your Board today is the first in a series of steps necessary to form a second Tourism Marketing District in Santa Cruz County. The Property and Business Improvement District Law of 1994 Section 36620 et. seq., sets out the sequence of events required for the District's formation and is included as Appendix I in the District Plan (Attachment A). In addition, the sequence of steps required to complete the process of forming the District are included as a separate document in Attachment B.

#### District Formation Process

The County was approached by representatives of the CVC and the SCCHLA to initiate and facilitate the proposed second District. The District boundaries would encompass all of Santa Cruz County and include an assessment paid by those lodging businesses with six (6) or more rooms located in the County and any participating cities. The cities must grant consent for the District to be formed within their city limits. Communication between the SCCHLA, the CVC, and our office indicates that there is interest by each City to participate in the formation of the District. Annual assessment rates for the second TMD would be \$0.50 per occupied room per night for lodging business. Because marketing funded by the assessment would not be provided for the smallest lodging businesses, businesses with less than six (6) rooms would be exempt from the assessment. Revenue raised by this assessment is anticipated to be \$400,000 per year. The second District will be formed for a period of two years, to run concurrently with the original TMD which expires July 1, 2015, at which time it can be renewed for up to 10 years.

Board of Supervisors  
 Agenda: May 14, 2013  
 Page 3

The County's role would be to form the District through a Declaration of Intent, gather consent of the cities, hold a public meeting and hearing and formally create the District through approval by your Board. The County would also serve in our capacity as tax collector for assessed parcels within our jurisdiction. Assessments would be collected by each participating jurisdiction for the eligible lodging properties in their jurisdictions, and collection of the assessments would be consistent with current TOT collection procedures and regulations. District assessments are proposed to begin on July 1, 2013 and payments would be remitted to the CVC on a quarterly basis. The CVC will have the responsibility to manage the operations of the District as provided in the District Plan.

The collection of assessment fees for properties located within the unincorporated area would occur at the same time as TOT is collected and would be collected by the Treasurer-Tax Collector's office. The County of Santa Cruz and each city will be paid a fixed administrative fee of 1% of the amount collected within their jurisdiction for the costs of administration, which is an estimate of the costs of services to be delivered by the jurisdictions. In the event that there are unanticipated actual additional costs, beyond the administrative fee, the jurisdictions will be paid any actual costs which exceed the fixed fee. Additional costs to provide for an audit and to recover delinquencies would be recovered from the District on a pay-as-you-go basis. Penalties and interest at the same level as currently provided under County Code for the collection of delinquent TOT fees will also be applied to the costs of collections. Costs associated with defending any challenges to the District are considered administrative costs and eligible for reimbursement. The fee for administration and any additional actual costs will be retained by the jurisdictions from the assessments collected. There will be no net county cost associated with forming a District in Santa Cruz County, or with collecting the assessments.

#### Summary and Conclusion

Tourism Marketing Districts are well established in California, and the current district has been used successfully to improve tourist occupancy in Santa Cruz County. The proposed second District would continue to provide a stable form of funding for the Conference and Visitors Council and would allow for better marketing of the assessed lodging businesses, thus better positioning ourselves in a changing marketplace.

Signed petitions (on file with the Clerk of the Board) indicate the willingness by the majority of the overnight accommodation businesses in Santa Cruz County to support the formation of a second Tourism Marketing District and to assess themselves the necessary fees associated with forming such a district, in order to market the assessed lodging businesses in an increasingly competitive market. These petitioners were presented with a draft of the District Plan for review prior to signing the petitions.

It is therefore recommended that your Board take the following actions:

1. Abandon the modification process for the original Tourism Marketing District as considered on April 9, 2013.
2. Accept and file this report on a proposed second Santa Cruz County Tourism and Marketing District;
3. Accept the signed petition from members of the lodging industry requesting that the County establish a county-wide second Tourism Marketing District, and

Board of Supervisors  
Agenda: May 14, 2013  
Page 4

4. Adopt the Resolution declaring the intention to establish the second Santa Cruz County Tourism Marketing District, and
5. Set the date of the Public Meeting for June 11, 2013 to consider public testimony and to establish a second Santa Cruz County Tourism Marketing District that would levy the proposed assessment as of July 1, 2013, and
6. Set the date of the required Public Hearing for June 28, 2013 to: establish a second Santa Cruz County Tourism Marketing District; to levy the proposed assessments for the roster of lodging properties; direct the Clerk of the Board to provide written notice to the lodging businesses subject to the assessment of the date and time of the hearing; and to provide that notice as required by Streets and Highways Code §36623, and
7. Adopt the Resolution requesting the consent of the cities of Capitola, Santa Cruz, Scotts Valley and Watsonville to create the second Santa Cruz County Tourism Marketing District and direct the Clerk of the Board to submit a certified copy of this resolution to the City Clerks for the cities of Capitola, Santa Cruz, Scotts Valley and Watsonville.

Very truly yours,

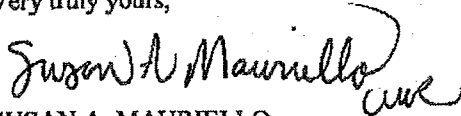

SUSAN A. MAURIELLO  
County Administrative Officer

- cc: Santa Cruz County Conference and Visitors Council  
Santa Cruz County Hospitality and Lodging Association  
Tom Morell, Attorney  
Auditor-Controller  
Treasurer Tax Collector  
County Counsel  
City of Capitola  
City of Santa Cruz  
City of Scotts Valley  
City of Watsonville

- Attachments: A. District Plan  
B. Property and Business Improvement District Law of 1994  
C. List of lodging businesses to be assessed with the second Santa Cruz County Tourism Marketing District  
D. Sequence of Events

Petitions of signatures from the Santa Cruz County Hospitality and Lodging Association members are on file with the Clerk of the Board.



## CITY COUNCIL AGENDA REPORT

MEETING OF MAY 23, 2013

FROM: DEPARTMENT OF PUBLIC WORKS

SUBJECT: CONSIDERATION OF FRAMEWORK FOR REVIEW OF PARKING METER PROGRAMS

**RECOMMENDED ACTION:** Approve the proposed schedule for consideration of changes to the City's parking meter program.

**BACKGROUND:** At the April 25, 2013, City Council meeting, Council Member Bottorff requested that the Traffic and Parking Commission explore, analyze and recommend pay station expansion for the following streets: Cherry Avenue, California Avenue, San Jose Avenue, Park Place, Stockton Avenue, and a portion of Capitola Avenue from the trestle to Monterey Avenue. He also requested that the Traffic and Parking Commission research and make recommendations for the parking time period and rate increases and decreases in the following areas: Village, Cliff Drive, and upper and lower Pacific Cove property.

**DISCUSSION:** Earlier this year the Council adopted Ordinance No. 978 which amended the Municipal Code (Code) and Local Coastal Plan (LCP) to change the language in the Code so that changes to the meter zone areas or rates does not require a LCP change, but rather could be done by issuing a Coastal Development Permit for those areas in the Coastal Zone. The Coastal Commission must approve this change before it goes into effect which is currently scheduled for the August 2013 Coastal Commission meeting.

In addition, pursuant to the State Vehicle Code, the City must set meter zones and rates by Ordinance. As State law trumps our local laws, the City must continue to codify the meter program, but can do so in a section of Code that is not contained in the LCP.

While the Traffic and Parking Commission has begun working on recommendations as requested, staff has prepared the attached proposed schedule for considering changes to the meter program that is consistent with the above two actions. The highest concern for staff is having an amended meter zone in place for the lower Pacific Cove parking lot when it is opened. To facilitate this, staff will be returning with a new Ordinance in June 2013 that will add the lower area to the Pacific Cove meter zone. This Ordinance will be scheduled to go into effect upon Coastal Commission approval of Ordinance No. 978.

Due to the timing of the Coastal Commission consideration of Ordinance No. 978, any rate changes and other area changes should be deferred until September 2013, and will require both a Coastal Development Permit and Ordinance revision.

**FISCAL IMPACT:** This item establishes the framework for holding hearings on the Parking Meter Program and has no fiscal impact at this time. Possible changes to meter areas and rates will impact the budgets for the parking meter program.

**ATTACHMENTS:**

1. Proposed 2013 Parking Meter Program Review Schedule
2. California Vehicle Code Section 22508

Report Prepared By: Steven Jesberg  
Public Works Director

Reviewed and Forwarded  
By City Manager: 



THIS PAGE INTENTIONALLY LEFT BLANK

**Proposed 2013 Parking Meter Program Review Schedule**

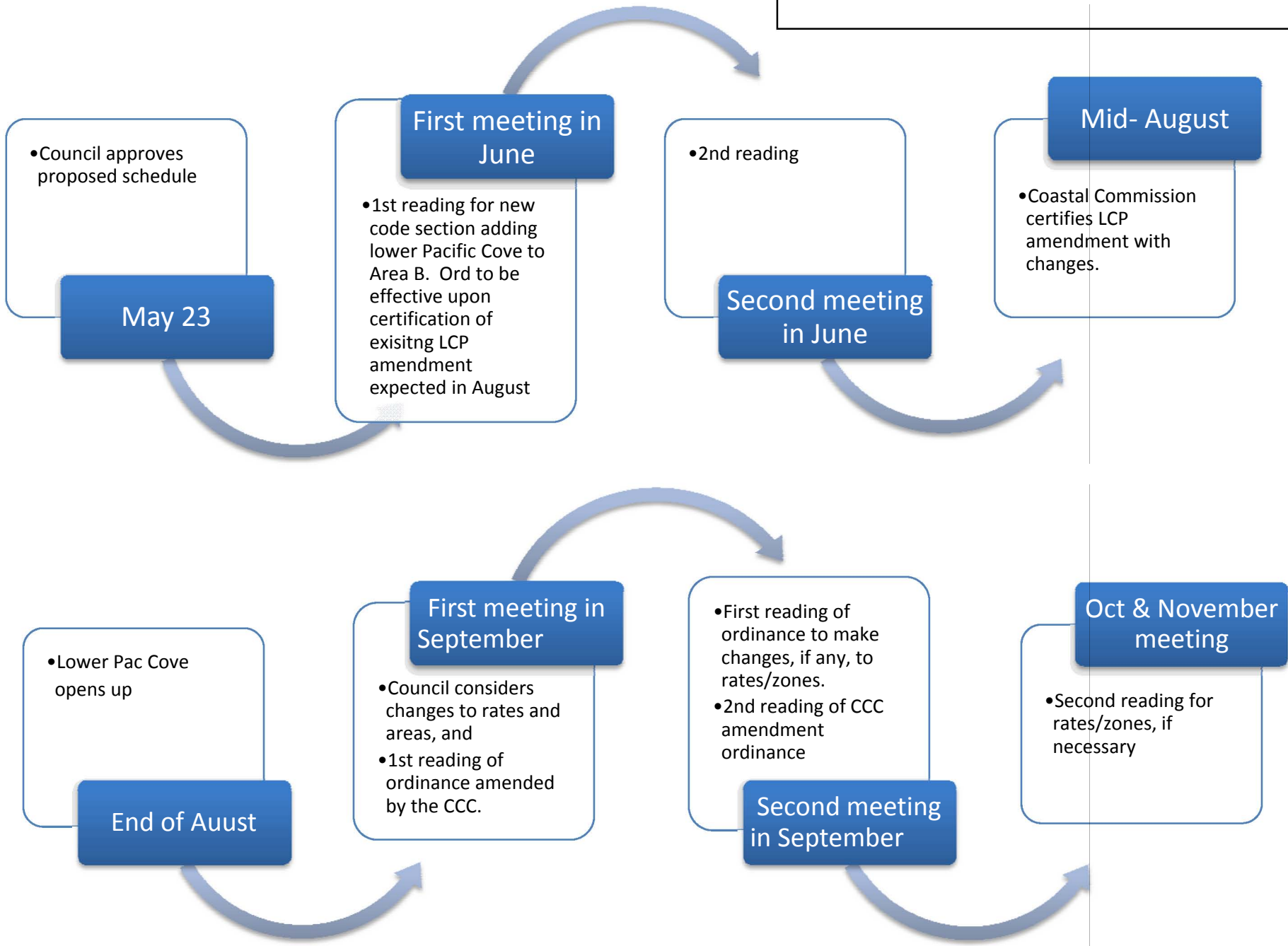

THIS PAGE INTENTIONALLY LEFT BLANK

## **VEHICLE CODE**

### **SECTION 22500-22526**

22508. (a) A local authority shall not establish parking meter zones or fix the rate of fees for those zones except by ordinance. The rate of fees may be variable, based upon criteria identified by the local authority in the ordinance. An ordinance establishing a parking meter zone shall describe the area that would be included within the zone.

(b) A local authority may by ordinance cause streets and highways to be marked with white lines designating parking spaces and require vehicles to park within the parking spaces.

(c) An ordinance adopted by a local authority pursuant to this section with respect to any state highway shall not become effective until the proposed ordinance has been submitted to and approved in writing by the Department of Transportation. The proposed ordinance shall be submitted to the department only by action of the local legislative body and the proposed ordinance shall be submitted in complete draft form.

(d) An ordinance adopted pursuant to this section establishing a parking meter zone or fixing rates of fees for that zone shall be subject to local referendum processes in the same manner as if the ordinance dealt with a matter of purely local concern.

(e) A local authority may accept but shall not require payment of parking meter fees by a mobile device.

THIS PAGE INTENTIONALLY LEFT BLANK



## CITY COUNCIL AGENDA REPORT

MEETING OF MAY 23, 2013

FROM: CITY CLERK

SUBJECT: CONSIDER LETTER OF OPPOSITION TO ASSEMBLY BILL 5

**RECOMMENDED ACTION:** Consideration of authorizing the Mayor to send a letter opposing Assembly Bill 5 – Homeless Person’s Bill of Rights and Fairness Act.

**DISCUSSION:** The City was contacted by the California League of Cities expressing concerns about Assembly Bill 5 – the Homeless Person’s Bill of Rights and Fairness Act. Despite opposition to AB 5, we share common ground with the intent of the bill. The City has taken a proactive response to end homelessness by partnering with local and regional nonprofit organizations to assist homeless individuals in obtaining housing and other services. The requirements imposed by the proposed legislation would create civil rights for a particular class of person at the expense of the general public.

The Act would require every local government within the state, including the City of Capitola, to develop and maintain health and hygiene centers available 24 hours a day, seven days a week, for use by homeless people. The Act would also require Capitola to compile and make public information regarding the number of citations, arrests, and other enforcement activities made regarding public nuisance activity. The Act may reduce the effectiveness of organizations working to solve homelessness by specifically authorizing camping on public and private property, potentially reducing the number of homeless individuals who would seek assistance. Furthermore, AB 5 would adversely affect the City’s ability to maintain safe, enjoyable, clean, and accessible public facilities.

The Act would provide that any person who believes their rights have been violated may file a motion against any person, entity, public entity, or public employee who has allegedly violated the person’s rights under the Act. The court may award punitive damages, appropriate injunctive and declaratory relief, actual damages, compensatory damages, general damages, special damages, exemplary damages, statutory damages of \$1,000 per violation in addition to attorney’s fees.

**FISCAL IMPACT:** If the bill is enacted, the following are some identified anticipated costs to the City:

- Increased operational, maintenance, staffing and utility costs for parks, restrooms and public property that must be accessible 24 hours a day, 7 days a week in order to allow homeless individuals the “right to rest and sleep in public spaces”
- Increased patrolling and policing costs associated with the free assembly on public property
- Increased costs of cleaning up public property in order to allow for homeless individuals “the right to set down or leave at rest personal property in public spaces”

**ATTACHMENT:**

1. Draft letter of opposition
2. April 9, 2013, League of California Cities letter
3. Opposition list
4. April 10, 2013, Aaron R. Maguire, California State Sheriff’s Association letter

Report Prepared By: Susan Sneddon  
City Clerk

Reviewed and Forwarded  
by City Manager:

THIS PAGE INTENTIONALLY LEFT BLANK



420 Capitola Avenue  
Capitola, California 95010  
Telephone: (831) 475-7300  
FAX: (831) 479-8879  
Website: [www.ci.capitola.ca.us](http://www.ci.capitola.ca.us)

May 24, 2013

The Honorable Tom Ammiano  
California State Assembly  
State Capitol Building, Room 3146  
Sacramento, CA 95814

**Re: Assembly Bill 2312 (Ammiano), Homelessness  
Notice of Opposition**

Dear Assembly Member Ammiano:

On behalf of the City of Capitola, I am writing to respectfully inform you that the City of Capitola opposes Assembly Bill 5.

The City understands the importance of addressing homelessness and believes in the basic rights of homeless individuals. Capitola has taken a proactive approach response to end homelessness by partnering with local and regional nonprofit organizations to assist homeless individuals in obtaining housing and other services. Homelessness is an issue facing almost every community in California, it is also important to preserve an individual community's flexibility to address the issue, as a one-size fits-all solution is not appropriate. This broad sweeping, one-size-fits-all approach does not work for addressing homelessness.

AB 5 would adversely affect the City's ability to respond to legitimate public health and safety issues and make it difficult for the City to respond to business concerns about loitering and panhandling. AB 5 would also divert State resources toward bill implementation and lead to fewer resources for ending homelessness, which should be the main objective of any legislation related to homelessness.

The Homeless Person's Bill of Rights and Fairness Act would, among other things, increase costs to local agencies in order to comply with the requirements of AB 5. For example, law enforcement agencies would be required to compile specific statistical information related to citation to homeless individuals and require reporting of that information to the Attorney General. At the same time, the legislation does not focus on the true issue that the state should be addressing: resources to end homelessness.

Furthermore, this Bill would confer on individuals that happen to be homeless a wide variety of "rights." These new protections include the right of homeless individuals to access and occupy virtually any public space, including sidewalks, parks, bus stops and plazas in the City, common areas of shopping centers and other private property, without regard to the rights of other individuals. The definition of "public space," to which the homeless individuals would be granted access includes places that receive additional services through Business Improvement Districts, or other, similar public-private partnerships.

The Bill could also potentially increase frivolous litigation by authorizing individuals the right to bring a lawsuit against public entities, including award of punitive damages and a minimum of \$1,000 to a person who believes that he or she has been harassed on the basis of being homeless.

While the City appreciates the intent of this bill, the City of Capitola believes that California would be better served by addressing the causes of homelessness, and providing resources to cities and counties to assist in solving the issue of homelessness, as opposed to limiting the rights of local agencies to address the issues within their boundaries.

For all of these reasons, the City of Capitola opposes AB 5. If you have any questions regarding our position, please contact Jamie Goldstein, Capitola City Manager, at (831) 475-7300.

Sincerely,

Stephanie Harlan  
Mayor, City of Capitola



THIS PAGE INTENTIONALLY LEFT BLANK



April 9, 2013

Assembly Member Tom Ammiano  
 State Capitol, Room 3146  
 Sacramento, CA 95814

**RE: AB 5 (Ammiano) Homelessness. NOTICE OF OPPOSITION (As amended April 8, 2013)**

Dear Assembly Member Ammiano:

On behalf of the League of California Cities, California Special Districts Association, and California Downtown Association we regretfully inform you of our opposition to your Assembly Bill 5, which would enact the Homeless Person's Bill of Rights and Fairness Act.

We recognize the interconnectedness of safe, decent, and permanent housing when addressing other needs of California's homeless population, such as mental health or substance abuse treatment, and unemployment. However, any solution must strike a balance between promoting health and safety for all residents and respecting the local designation of resources. Unfortunately, AB 5 would create costly mandates, blur the line between local jurisdiction authority, and undermine the local decision making process. Specifically, AB 5 would:

- Increase costs for local law enforcement at a time when funding for public safety is scarce by requiring the annual compilation and reporting of statistics on violations related to obstructing a sidewalk, loitering, sitting, lying down, sleeping in public, soliciting donations, bathing in public places, sleeping in a vehicle, jaywalking, and trespassing.
- Usurp local authority by prohibiting the enforcement of existing local ordinances if the county does not maintain year-round nonmedical assistance and there are fewer than 50 people on the county's public housing waiting list. Special districts and cities do not have authority over county actions, and yet they would still have their local authority hindered based on the counties actions.
- Provide civil and criminal protections for local agency employees who make that agency's property and resources available for use or distribution to homeless persons without the consent of that local agency.
- Require *every* local government to have health and hygiene centers with access 24 hours a day, seven days a week to bathroom and shower facilities. This requirement also confuses the autonomy of cities and special districts regarding oversight and administration.
- Increase court costs and inhibit revenue collection by guaranteeing persons the right to counsel for failure to appear or pay bail, in addition to providing ample opportunities to file a lawsuit and recover money.

Despite our opposition to AB 5, we share some common ground with the intent of the bill. Local governments strive to assist those in need by offering housing, mental health counseling, and other services. As such, we believe that other legislation introduced this year would more appropriately create solutions for California's homeless. These include AB 639 (J. Perez), which would repurpose existing bond money authorized to assist veterans with housing and SB 391 (DeSaulnier), which would provide a reliable and steady source of affordable housing money.

Please do not hesitate to contact the undersigned should you have questions about our opposition to AB 5.

Sincerely,

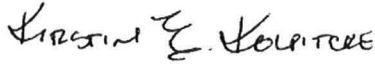

Kirstin Kolpitke  
Legislative Representative  
League of California Cities  
[kkolpitke@cacities.org](mailto:kkolpitke@cacities.org)



Dorothy Holzem  
Legislative Representative  
California Special Districts Association  
[dorothyh@csda.net](mailto:dorothyh@csda.net)



John Lambeth  
Legislative Committee Chair  
California Downtown Association

cc: Chair and Members, Assembly Judiciary Committee  
Kevin Baker, Deputy Chief Counsel, Assembly Judiciary Committee  
Paul Dress, Consultant, Senate Republican Caucus

## AB 5 (Ammiano) -HOMELESS PERSONS BILL OF RIGHTS

Opposition List

Air Conditioning Trade Association  
 Association of California Cities – Orange County  
 Building Owners and Managers Association of California  
 California Chamber of Commerce  
 California Apartment Association  
 California Association of Joint Powers Authority  
 California Business Properties Association  
 California Downtown Association  
 California Farm Bureau Federation  
 California Grocers Association  
 California Hotel & Lodging Association  
 California Manufacturers and Technology Association  
 California Park & Recreation Society  
 California Police Chiefs Association  
 California Special Districts Association  
 California State Sheriffs' Association  
 California Travel Association  
 Central City East Association  
 City of Bellflower  
 City of Buena Park  
 City of Concord  
 City of Corona  
 City of Cypress  
 City of Lake Forrest  
 City of Palmdale  
 City of Menifee  
 City of Signal Hill  
 City of Thousand Oaks  
 Civil Justice Association of California  
 County of Lassen  
 Desert Water Agency  
 East Bay Rental Housing Association  
 Historic Downtown Los Angeles Business Improvement District  
 Hollister Downtown Association  
 Hollywood Property Owners Alliance  
 International Council of Shopping Centers  
 League of California Cities  
 Midtown Business Association  
 NAIOP of California, the Commercial Real Estate Development Association  
 National Federation of Independent Business - California  
 NORCAL Rental Property Association  
 Orange County Business Council  
 Plumbing-Heating-Cooling Contractors Association of California  
 San Jose Downtown Association  
 Save the American River Association  
 South Park Community Benefit District

**Item #: 9.E. Attach 3.pdf**

The Apartment Association, California Southern Cities  
The River District  
Western Electrical Contractors Association



## California State Sheriffs' Association

Organization Founded by the Sheriffs in 1894

### Officers

*President*  
Keith Royal  
*Sheriff, Nevada County*

*1st Vice President*  
Greg Ahern  
*Sheriff, Alameda County*

*2nd Vice President*  
Adam Christianson  
*Sheriff, Stanislaus County*

*Secretary*  
Martin Ryan  
*Sheriff, Amador County*

*Treasurer*  
Donny Youngblood  
*Sheriff, Kern County*

*Sergeant-at-Arms*  
Bill Brown  
*Sheriff, Santa Barbara County*

Al Cooper  
*Sergeant-at-Arms, Emeritus*

*Immediate Past President*  
Mark N. Pazin  
*Sheriff, Merced County*

### Directors

Tom Bosenko  
*Sheriff, Shasta County*

John Crawford  
*Sheriff, Alpine County*

Steve Durfor  
*Sheriff, Yuba County*

Steve Freitas  
*Sheriff, Sonoma County*

Dean Growdon  
*Sheriff, Lassen County*

Sandra Hutchens  
*Sheriff, Orange County*

David Livingston  
*Sheriff, Contra Costa County*

Margaret Mims  
*Sheriff, Fresno County*

Steve Moore  
*Sheriff, San Joaquin County*

Ed Prieto  
*Sheriff, Yolo County*

Bill Wittman  
*Sheriff, Tulare County*

### Presidents' Counsel

Ed Bonner  
*Sheriff, Placer County*

Robert Doyle  
*Sheriff, Marin County*

Laurie Smith  
*Sheriff, Santa Clara County*

M. Carmen Green  
*Deputy Executive Director*

Nick Warner  
*Legislative Director*

Martin J. Mayer  
*General Counsel*

April 10, 2013

The Honorable Bob Wieckowski  
Chair, Assembly Judiciary Committee  
State Capitol Building, 4016  
Sacramento, CA 95814

**Subject: Assembly Bill 5 (Ammiano) – CSSA Oppose**

Dear Assemblymember Wieckowski:

On behalf of the California State Sheriffs' Association (CSSA), we regret to inform you that we must oppose measure AB 5, which would enact the Homeless Person's Bill of Rights and Fairness Act.

CSSA is concerned that the rights conferred by this bill – the right to occupy vehicles and public places, the right to sleep in public places, the right to access public facilities 24/7, and right to solicit funds (pan handle) – would unnecessarily interfere with communities' attempts to address serious public health and safety issues. In addition, CSSA is troubled with the findings in Section 1 of the bill that allege law enforcement officials unfairly target homeless persons, "often resulting in the violation of the homeless persons' constitutional rights." Dealing with homeless populations is a difficult and challenging task, oftentimes requiring balancing the interests of many while attempting to protect the safety and public health of all members of the community. To suggest that law enforcement is regularly violating the constitutional rights of any members of the community, homeless or otherwise, is unwarranted and we request such language be removed from this bill.

For these reasons we must respectfully oppose AB 5.

Sincerely,

Aaron R. Maguire  
Legislative Representative

Cc: The Honorable Tom Ammiano, Member, California State Assembly  
The Honorable Donald Wagner, Vice- Chair, Assembly Judiciary Committee

1231 I Street, Ste 200 ★ Sacramento, California 95814  
P O Box 958 ★ Sacramento, California 95812

Telephone 916/375-8000 ★ Fax 916/375-8017 ★ Website www.calsheriffs.org ★ Email cssa@calsheriffs.org

THIS PAGE INTENTIONALLY LEFT BLANK