



# **SPECIAL MEETING AGENDA**

## **CAPITOLA PLANNING COMMISSION**

### **Monday, June 13, 2016 – 6:30 PM**

Chairperson            T.J. Welch  
Commissioners        Ed Newman  
                                  Gayle Ortiz  
                                  Linda Smith  
                                  Susan Westman

#### **1. ROLL CALL AND PLEDGE OF ALLEGIANCE**

#### **2. ORAL COMMUNICATIONS**

##### **A. Additions and Deletions to Agenda**

##### **B. Public Comments**

*Short communications from the public concerning matters not on the Agenda. All speakers are requested to print their name on the sign-in sheet located at the podium so that their name may be accurately recorded in the Minutes.*

##### **C. Commission Comments**

##### **D. Staff Comments**

#### **3. PUBLIC HEARINGS**

*Public Hearings are intended to provide an opportunity for public discussion of each item listed as a Public Hearing. The following procedure is as follows: 1) Staff Presentation; 2) Public Discussion; 3) Planning Commission Comments; 4) Close public portion of the Hearing; 5) Planning Commission Discussion; and 6) Decision.*

##### **A. Zoning Code Update                      All Properties within Capitola**

Continuation of Comprehensive Update to the City of Capitola Zoning Code (Municipal Code Chapter 17)

The Zoning Code serves as the Implementation Plan of the City's Local Coastal Program and therefore must be certified by the Coastal Commission.

Environmental Determination: Addendum to the General Plan Update EIR

Property: The Zoning Code update affects all properties within the City of Capitola.

Representative: Katie Cattan, Senior Planner, City of Capitola

#### **4. DIRECTOR'S REPORT**

#### **5. COMMISSION COMMUNICATIONS**

#### **6. ADJOURNMENT**

**APPEALS:** The following decisions of the Planning Commission can be appealed to the City Council within the (10) calendar days following the date of the Commission action: Conditional Use Permit, Variance, and Coastal Permit. The decision of the Planning Commission pertaining to an Architectural and Site Review can be appealed to the City Council within the (10) working days following the date of the Commission action. If the tenth day falls on a weekend or holiday, the appeal period is extended to the next business day.

All appeals must be in writing, setting forth the nature of the action and the basis upon which the action is considered to be in error, and addressed to the City Council in care of the City Clerk. An appeal must be accompanied by a one hundred forty two dollar (\$142.00) filing fee, unless the item involves a Coastal Permit that is appealable to the Coastal Commission, in which case there is no fee. If you challenge a decision of the Planning Commission in court, you may be limited to raising only those issues you or someone else raised at the public hearing described in this agenda, or in written correspondence delivered to the City at, or prior to, the public hearing.

**Notice regarding Planning Commission meetings:** The Planning Commission meets regularly on the 1<sup>st</sup> Thursday of each month at 7:00 p.m. in the City Hall Council Chambers located at 420 Capitola Avenue, Capitola.

**Agenda and Agenda Packet Materials:** The Planning Commission Agenda and complete Agenda Packet are available on the Internet at the City's website: [www.cityofcapitola.org](http://www.cityofcapitola.org). Agendas are also available at the Capitola Branch Library, 2005 Wharf Road, Capitola, on the Monday prior to the Thursday meeting. Need more information? Contact the Community Development Department at (831) 475-7300.

**Agenda Materials Distributed after Distribution of the Agenda Packet:** Materials that are a public record under Government Code § 54957.5(A) and that relate to an agenda item of a regular meeting of the Planning Commission that are distributed to a majority of all the members of the Planning Commission more than 72 hours prior to that meeting shall be available for public inspection at City Hall located at 420 Capitola Avenue, Capitola, during normal business hours.

**Americans with Disabilities Act:** Disability-related aids or services are available to enable persons with a disability to participate in this meeting consistent with the Federal Americans with Disabilities Act of 1990. Assisted listening devices are available for individuals with hearing impairments at the meeting in the City Council Chambers. Should you require special accommodations to participate in the meeting due to a disability, please contact the Community Development Department at least 24 hours in advance of the meeting at (831) 475-7300. In an effort to accommodate individuals with environmental sensitivities, attendees are requested to refrain from wearing perfumes and other scented products.

**Televised Meetings:** Planning Commission meetings are cablecast "Live" on Charter Communications Cable TV Channel 8 and are recorded to be replayed on the following Monday and Friday at 1:00 p.m. on Charter Channel 71 and Comcast Channel 25. Meetings can also be viewed from the City's website: [www.cityofcapitola.org](http://www.cityofcapitola.org).



## STAFF REPORT

TO: PLANNING COMMISSION

FROM: COMMUNITY DEVELOPMENT

DATE: JUNE 13, 2016

SUBJECT: **Zoning Code Update All Properties within Capitola**

Continuation of Comprehensive Update to the City of Capitola Zoning Code (Municipal Code Chapter 17)

The Zoning Code serves as the Implementation Plan of the City's Local Coastal Program and therefore must be certified by the Coastal Commission.

Environmental Determination: Addendum to the General Plan Update EIR  
 Property: The Zoning Code update affects all properties within the City of Capitola.

Representative: Katie Cattan, Senior Planner, City of Capitola

**BACKGROUND:** The draft zoning code was released on February 4, 2016, for an extended public review and comment period. The Planning Commission began the review of the draft zoning code on March 3 and held subsequent meetings on March 17, April 18, April 21, May 5, May 16, and May 19. The draft code, zoning map, and previous staff reports with attachments are available online at: <http://www.cityofcapitola.org/communitydevelopment/page/zoning-code-update>.

**DISCUSSION:** The draft zoning code has been reviewed sequentially from beginning to end, except for the following chapters: 17.84 Historic Preservation, 17.114 Conceptual Review, 17.160 Glossary, and coastal chapters. Staff summarized the direction provided by the Planning Commission to date in the minor edits list and discussion list (Attachments 2 and 3).

Part 1 and Part 2 of the draft zoning code have been update to include the direction provided by the Planning Commission (Attachment 1). The Planning Commission edits to the initial draft are shown in red. During the June 13, 2016 special meeting, the Planning Commission will review the redlines of Part 1 and Part 2 of the draft code and provide staff with additional edits and/or direction to prepare draft for positive recommendation to City Council.

It is anticipated that the following sections will be discussed during the June meetings:

Meeting Date	Sections to Be Reviewed
June 13	Part 1 and Part 2 Redlines 17.84 Historic Preservation 17.114 Conceptual Review
June 27	17.44 Coastal Overlay Zone 17.64 Environmentally Sensitive Habitat Areas 17.68 Geological Hazards

	17.92 Nonconforming Parcels, Uses, and Structures 17.136 Minor Modifications 17.104 Wireless Communications Part 5 Glossary
Pending	Part 3 Redlines Part 4 Redlines Part 5 Redlines

Commissioner Westman requested an overview of the historic preservation efforts to date in Capitola, in preparation for the review of Chapter 17.84. The following list includes the year and a short description of the City's historic preservation effort:

- 1982: Capitola Register of Historic Features. The City Council adopted a Historic Features Ordinance. The ordinance established a procedure for establishing historic features, as well as the findings and criteria required for designation. The ordinance requires that a conditional use permit be approved by the Planning Commission for any material change to the historic feature. 15 features exist on the Capitola Register of Historic Features.
- 1986: Capitola Architectural Survey. The survey includes approximately 240 structures that best represent traditional architectural styles locally and the community vernacular architecture. The survey was not officially adopted pursuant to an ordinance or resolution, and therefore the structures listed within it are not considered official historical resources. The structures are considered potentially significant resources. The list of properties included in the architectural survey are included as Attachment 4.
- 1986: Consultant Historic Survey. Historic consultants surveyed the City and determined 13 "buildings of local interest" are eligible for inclusion on the California Historic Resources Inventory and/or eligible for nomination to the National Register of Historic Places.
- 1987: National Historic Districts. Three National Register Historic Districts were established in the City of Capitola: Venetian Court Historic District, Six Sisters/Lawn Way Historic District, and the Old Riverview Historic District.
- 1998: Historic Resource Committee. The City Council approved the formation of the Historic Resources Committee, a subcommittee of the Planning Commission to assist with development of a historic preservation program. The Committee focused its initial efforts on identifying potentially historic resources with the City. The subcommittee worked with the Capitola Museum Director, Carolyn Swift, to create a draft list of historic resources (Attachment 5). Staff did not find evidence of this list being officially adopted by the City Council, therefore the structures on the list are considered potentially significant resources.
- 2000: Draft Policy Document. "Processing Development Applications Involving Historic Resources" is drafted as a policy document intended to function as an interim policy document while a comprehensive historic preservation program is prepared.
- 2004: Historic Context Statement. City hires Museum Director, Carolyn Swift, to prepare the Historic Contexts Statement for the City of Capitola.
- 2004: Depot Hill Historic District Feasibility Study. City hires Archives and Architecture to prepare the Depot Hill Historic District Feasibility Study.

- 2005: List of Historic Resource. City Council authorized the Museum Director, Carolyn Swift, and Historic Consultant, Kathryn Gualtieri, to draft a comprehensive list of historic resources. The list combined all prior resources including: the initial Capitola Architectural Survey, the Depot Hill Historic District Feasibility Study, the Capitola Historic Context Statement, the Capitola Register of Historic Features, and structures individually designated or within National and California Register historic district. The list was never formally adopted by City Council, therefore the structures listed within it are not considered official historical resources. The structures are considered potentially significant resources (Attachment 6). The 2005 list is referred to in the draft Zoning Code Chapter 17.84 Section 020 as the Historic Structures List. The draft ordinance specifies that the list is maintained as an inventory of properties that are potentially historic. The list is used only as a screening tool for staff to help determine when additional historic analysis is necessary.

**CEQA:** An Addendum to the General Plan Update Environmental Impact Report has been prepared.

**RECOMMENDATION:** Accept the staff presentation, discuss Part 1 and Part 2 redlines of the draft zoning code, identify desired code revisions, and continue the public hearing to the June 27, 2016 meeting.

**ATTACHMENTS:**

1. Part 1 and Part 2 Draft Zoning Code PC Redlines
2. PC Edits List
3. PC Discussion List
4. 1986 List of Properties in Capitola Architectural Survey
5. 1998 Historic Resource Committee draft historic resource list
6. 2005 Historic Resources List
7. 17.114 Conceptual Review Draft Chapter

Prepared By: Katie Cattan  
Senior Planner

## Chapter 17.04 – PURPOSE AND EFFECT OF ZONING CODE

### Sections:

- 17.04.010 Title and Authority
- 17.04.020 Purpose of the Zoning Code
- 17.04.030 Relationship to the General Plan
- 17.04.040 Applicability of the Zoning Code

#### 17.04.010 Title and Authority

Title 17 of the Capitola Municipal Code shall be known and cited as the “Capitola Zoning Code” and referred to in this title as “the Zoning Code.” The Zoning Code is adopted pursuant to the authority in Section 65850 of the California Government Code.

#### 17.04.020 Purpose of the Zoning Code

- A. **General.** The purpose of the Zoning Code is to implement the General Plan and to protect the public health, safety, and welfare.
- B. **Specific.** The Zoning Code is intended to:
  1. Preserve and enhance Capitola’s small-town feel and coastal village charm.
  2. Ensure that all development exhibits high-quality design that supports a unique sense of place.
  3. Protect and enhance the quality of life in residential neighborhoods.
  4. Encourage active and inviting commercial and mixed-use areas.
  5. Support a vibrant, diverse, and dynamic local economy.
  6. Allow for a broad range of housing choices that meets the needs of all segments of the community.
  7. Protect and enhance natural resources that contribute to Capitola’s unique identity and scenic beauty.
  8. Maintain and enhance coastal access and visitor-serving facilities and services.
  9. Protect and preserve the Capitola’s historic resources.
  10. Support a balanced transportation system that accommodates the needs of automobiles, pedestrians, ~~and~~ bicycles, and other forms of transportation.

#### 17.04.030 Relationship to the General Plan

The Zoning Code implements the General Plan by regulating the use of land and structures in Capitola. If the Zoning Code conflicts with the General Plan, the General Plan governs.

**17.04.040 Applicability of the Zoning Code**

- A. Applicability to Property.** The Zoning Code applies to all land, uses, and structures within the Capitola city limits.
- B. Compliance with Regulations.** All uses, structures, and development activity in Capitola shall comply with the Zoning Code.
- C. Conflicting Regulations.** Where conflict occurs with other ~~E~~city regulations or with State or federal laws, higher law shall control over lower law unless local variation is permitted. Where conflicting laws are of equal stature, the more restrictive shall control unless otherwise specified in the Zoning Code or in State or federal law.

## Chapter 17.08 – INTERPRETATION

### Sections:

- 17.08.010 Purpose
- 17.08.020 Authority
- 17.08.030 Rules of Interpretation
- 17.08.040 Procedures for Interpretation/Determinations
- 17.08.050 Zoning Code Enforcement

### 17.08.010 Purpose

This chapter establishes rules and procedures for interpreting the Zoning Code to ensure that it is applied and enforced in a consistent manner.

### 17.08.020 Authority

The City Council delegates to the Community Development Director and the Director's designees the authority in accordance with 17.08.040 to interpret the meaning and applicability of all provisions in the Zoning Code.

### 17.08.030 Rules of Interpretation

**A. General Rules.** Rules of interpretation in Municipal Code Chapter 1.04 (General Provisions) apply to the Zoning Code. The following general rules also apply to the interpretation and application of the Zoning Code.

1. In the event of any conflict between the provisions of this Zoning Code, the most restrictive requirement shall control.
2. Where there is a conflict between text and any figure, illustration, graphic, heading, map, table, or caption, the text governs.
3. The words “shall,” “will,” “is to,” and “are to” are mandatory. “Should” means a regulation that is not mandatory, but must be either fulfilled or the applicant must demonstrate an alternative that fulfills the intent of the regulation or that a non-economic hardship makes compliance infeasible. “May” is permissive.
4. The following conjunctions are interpreted as follows
  - a. “And” means that all items or provisions so connected apply.
  - b. “Or” means that all items or provisions so connected apply singularly or in any combination.
  - c. “Either . . . or” means that one of the items or provisions so connected apply singularly, but not in combination.
5. All officials, bodies, agencies, ordinances, policies, and regulations referred to in the Zoning Code are those of Capitola unless otherwise noted.



- B. Calendar Days.** Numbers of days specified in the Zoning Code are continuous calendar days unless otherwise noted. Where the last of a number of days falls on a holiday or weekend, time limits are extended to the following working day.
- C. Land Use Regulation Tables.** Land use regulation tables in Part 2 (Zoning Districts and Overlay Zones) establish permitted land uses within each zoning district. Notations within these tables have the following meanings:
1. **Permitted Uses.** A “P” means that a use is permitted by right in the zoning district and is not subject to discretionary review and approval.
  2. **Administrative Permit.** An “A” means the use is permitted with the approval of an Administrative Permit.
  3. **Minor Use Permit.** An “M” means that a use requires approval of a Minor Use Permit.
  4. **Conditionally Permitted Uses.** A “C” means that a use requires approval of a Conditional Use Permit.
  5. **Uses Not Allowed.** A “-” means that a use is not allowed in the zoning district.



**Note:** Procedures and criteria for addressing unlisted land uses in Subsection D below are new.

- D. Unlisted Land Uses.** If a proposed land use is not listed in the Zoning Code, the use is not permitted except as follows:
1. An unlisted use is not permitted if the use is listed as a permitted use in one or more other zoning districts. In such a case, the absence of the use in the zoning district within the land use table means that the use is prohibited in the zoning district.
  2. The Community Development Director may determine that an unlisted proposed use is equivalent to a permitted or conditionally permitted use if all of the following findings can be made:
    - a. The use is similar to other uses allowed in the zoning district.
    - b. The density or intensity of the use is similar to other uses in the zoning district.
    - c. The use is compatible with permitted or conditionally permitted uses in the zoning district.
    - d. The use will meet the purpose of the zoning district.
    - e. The use is consistent with the goals and policies of the General Plan.
    - f. The use will not be detrimental to the public health, safety, or welfare.
  3. When the Community Development Director determines that a proposed use is equivalent to a listed use, the proposed use shall be treated in the same manner as the listed use with respect to development standards, permits required, and all applicable requirements of the Zoning Code.

**E. Zoning Map Boundaries.** Where uncertainty exists as to the boundaries of zoning districts as shown on the Zoning Map, the following rules apply:

1. Boundaries shown as approximately following the centerlines of streets, highways, or alleys are construed to follow the centerlines.
2. Boundaries shown as approximately following platted lot lines are construed as following the lot lines.
3. Boundaries shown as approximately following city limits are construed as following city limits.
4. Boundaries shown following railroad lines are construed to be midway between the main tracks.
5. In unsubdivided property or where a zoning district boundary divides a parcel, the location of the boundary are determined by the use of the scale appearing on the Zoning Map.
6. In case further uncertainty exists, the Community Development Director shall determine the exact location of the boundaries. The Director's decision may be appealed to the Planning Commission to determine the exact location of the boundaries.

**F. Parcels Containing Two or More Zoning Districts.**

1. For parcels containing two or more zoning districts ("split zoning"), the location of the zoning district boundary shall be determined by the Community Development Director. The Director's decision may be appealed to the Planning Commission to determine the exact location of the boundaries.
2. For parcels containing two or more zoning districts, the regulations for each zoning district shall apply within the zoning district boundaries as identified on the Zoning Map.

**17.08.040 Procedures for Interpretation/Determinations**



**Note:** Procedures for responding to Zoning Code interpretation requests in Section 17.08.040 are new.

**A. Request for Interpretation.** The Community Development Director shall respond in writing to written requests for interpretation of the Zoning Code if the requested interpretation would substantially clarify an ambiguity which interferes with the effective administration of the Zoning Code. The following procedures apply for a request for interpretation:

1. The request shall be in writing, shall identify the provision to be interpreted, and shall be accompanied by the fee identified in the latest Fee Schedule.

2. The request shall provide any information that the Director requires to assist in its review.
3. The Director shall respond to an interpretation request within 30 days of receiving the request.

- B. Form and Content of Interpretation.** Official interpretations prepared by the Director shall be in writing, and shall quote the Zoning Code provisions being interpreted. The interpretation shall describe the circumstance that caused the need for the interpretation.
- C. Official Record of Interpretations.** An official record of interpretations shall be kept and updated regularly by the Community Development Department. The record of interpretations shall be indexed by the number of the section that is the subject of the interpretation and made available for public inspection during normal business hours.
- D. Referral to Planning Commission.** The Director may refer any request for interpretation of the Zoning Code to the Planning Commission for review and interpretation.
- E. Appeals.** Any official interpretation prepared by the Director may be appealed to the Planning Commission. The Planning Commission's interpretation may be appealed to the City Council. Appeals shall be accompanied by the fee identified in the latest Fee Schedule.

#### 17.08.050 Zoning Code Enforcement

Enforcement of the Zoning Code shall occur in a manner consistent with Capitola Municipal Code Title 4 (General Municipal Code Enforcement).

## Chapter 17.12 – ZONING DISTRICTS AND MAP

**Sections:**

- 17.12.010 Purpose
- 17.12.020 Zoning Districts
- 17.12.030 Zoning Map

**17.12.010 Purpose**

This chapter identifies the zoning districts that apply to land within the Capitola city limits and establishes the official Capitola Zoning Map.

**17.12.020 Zoning Districts**

**A. Base Zoning Districts.** Capitola is divided into zoning districts that implement the General Plan Land Use Map as shown in Table 17.12-1.



**Note:** There have been some changes to existing zoning districts and overlay zones as shown in Table 17.12-1 and Table 17.12.-2. Changes include creating a new Neighborhood Mixed Use zoning districts for portions of Capitola Road, Bay Avenue, and Capitola Avenue, distinguishing between the Community Commercial and Regional Commercial zoning districts along 41<sup>st</sup> Avenue, deleting the Automatic Review overlay, and changing the Archaeological/Paleontological Resources overlay and Geological Hazards overlay into citywide standards.

**TABLE 17.12-1: BASE ZONING DISTRICTS**

Zoning District Symbol	Name of Zoning District	General Plan Land Use Designation
<b>Residential Zoning Districts</b>		
R-1	<del>Single-Family</del> Residential <u>Single-Family</u>	Single-Family Residential (R-SF)
RM-L	<del>Multi-Family</del> Residential <u>Multi-Family</u> , Low Density	Multi-Family Residential (R-MF)
RM-M	<del>Multi-Family</del> Residential <u>Multi-Family</u> , Medium Density	
RM-H	<del>Multi-Family</del> Residential <u>Multi-Family</u> , High Density	
MH	Mobile Home Park	Mobile Home Park (MH)
<b>Mixed-Use Zoning Districts</b>		

Attachment: Part 1 and Part 2 Draft Zoning Code PC Redlines (1512 : Zoning Code Update)

Zoning District Symbol	Name of Zoning District	General Plan Land Use Designation
MU-V	<del>Village</del> -Mixed Use, <u>Village</u>	Village Mixed-Use (MU-V)
MU-N	<del>Neighborhood</del> -Mixed Use, <u>Neighborhood</u>	Neighborhood Mixed-Use (MU-N)
<b>Commercial and Industrial Zoning Districts</b>		
C-C	<del>Community</del> -Commercial, <u>Community</u>	Community Commercial (C-C)
C-R	<del>Regional</del> -Commercial, <u>Regional</u>	Regional Commercial (C-R)
I	Industrial	Industrial (I)
<b>Other Zoning Districts</b>		
VS	Visitor Serving	Visitor Accommodations (VA)
CF	Community Facility	Public/Quasi-Public Facility (P/QP)
P/OS	Parks and Open Space	Parks and Open Space (P/OS)
PD	Planned Development	N/A

**B. Overlay Zones.** The Zoning Code and Zoning Map include the overlay zones shown in Table 17.12-2. Overlay zones impose additional regulations on properties beyond what is required by the underlying base zoning district.

**TABLE 17.12-2: OVERLAY ZONES**

Overlay Zone Symbol	Name of Overlay Zone
-AH	Affordable Housing
-VRU	Vacation Rental Use
-VR	Village Residential
-CZ	Coastal Zone

**17.12.030 Zoning Map**

**A. Adoption.** The City Council hereby adopts the Capitola Zoning Map (“Zoning Map”), which establishes the boundaries of all base zoning districts and overlay zones provided for in the Zoning Map.

Attachment: Part 1 and Part 2 Draft Zoning Code PC Redlines (1512 : Zoning Code Update)

- B. Incorporation by Reference.** The Zoning Map, including all legends, symbols, notations, references, and other information shown on the map, is incorporated by reference and made a part of the Zoning Code.
- C. Location.** The Zoning Map is kept, maintained, and updated electronically by the Community Development Department, and is available for viewing by the public at the Department ~~and on the official City of Capitola website.~~

## Chapter 17.16 – RESIDENTIAL ZONING DISTRICTS

### Sections:

- 17.16.010 Purpose of the Residential Zoning Districts
- 17.16.020 Land Use Regulations
- 17.16.030 Development Standards

### 17.16.010 Purpose of the Residential Zoning Districts

**A. General.** The purpose of the residential zoning districts is to support attractive, safe, and friendly neighborhoods consistent with Capitola’s intimate small-town feel and coastal village charm. Development within the residential zoning districts features high quality design that enhances the visual character of the community. The mass, scale, and design of new homes are compatible with existing homes in neighborhoods and are carefully designed to minimize impacts to existing homes. Residential zoning districts contain a range of housing types and community facilities to support diverse and complete neighborhoods with a high quality of life for residents.

### B. Specific.

1. ~~Single-Family Residential~~ **Residential Single-Family (R-1) Zoning District.** The purpose of the R-1 zoning district is to protect and enhance the unique qualities of individual neighborhoods in Capitola. The R-1 zoning district allows for variation in development standards based on the existing development patterns within these neighborhoods. New development respects the existing scale, density, and character of neighborhoods to strengthen Capitola’s unique sense of place.
2. ~~Residential Multi-Family Residential~~ **(RM) Zoning District.** The purpose of the RM zoning district is to accommodate a range of housing types to serve all Capitola residents. The RM zoning districts allows single-family and multi-family housing at higher densities to maintain and increase the supply of affordable housing choices. Housing in the RM zoning districts ~~is~~ will be carefully designed to enhance Capitola’s unique identity and to minimize impacts on adjacent land uses and structures. The RM zone is divided into three subzones (RM-L, RM-M, and RM-H) allowing for a range of permitted residential densities.
3. **Mobile Home Park (MH) Zoning District.** The MH zone provides areas for exclusive development of mobile home parks. Mobile home parks provide a valuable source of affordable housing serving Capitola’s lower-income and senior residents.

### 17.16.020 Land Use Regulations

**A. Permitted Land Uses.** Table 17.16-1 identifies land uses permitted in the residential zoning districts.



**Note:** Some land use terms in the existing Zoning Code have been changed in the updated Zoning Code to reflect current usage and State law. Despite this change, permitted land uses in the residential zoning districts have generally remained the same.

**TABLE 17.16-1: PERMITTED LAND USES IN THE RESIDENTIAL ZONING DISTRICTS**

Key	Zoning District			Additional Regulations
	R-1	RM	MH	
<b>P</b> Permitted Use				
<b>A</b> Administrative Permit required				
<b>M</b> Minor Use Permit required				
<b>C</b> Conditional Use Permit required				
<b>-</b> Use not allowed				
<b>Residential Uses</b>				
Duplex Homes	-	P	-	
Elderly and Long Term Care	-	C	-	
Group Housing	-	P	-	
Mobile Home Parks	-	C	P [1]	Chapter 17.100
Multi-Family Dwellings	-	P	-	
Residential Care Facilities, Small	P	P	C [2]	
Residential Care Facilities, Large	C	C	C [2]	Section 17.96.080
Secondary Dwelling Units	A	A	-	Chapter 17.74
Single-Family Dwellings	P	P	C [2]	
<b>Public and Quasi-Public Uses</b>				
Community Assembly	C	C	C	
Day Care Centers	C	C	C	
Home Day Care, Large	M	M	M	Section 17.96.070
Home Day Care, Small	P	P	P	
Parks and Recreational Facilities	-	C	C	
Schools, Public or Private	-	C	C	
<b>Commercial Uses</b>				
Bed and Breakfast	C	C	-	
Vacation Rentals	See Section 17.4032.0340			
<b>Transportation, Communication, and Utility Uses</b>				
Utilities, Major	C	C	C	
Utilities, Minor	P	P	P	
Wireless Communications Facilities	See Chapter 17.104			
<b>Other Uses</b>				
Accessory Uses and Structure	P [3]	P [3]	P[3]	Chapter 17.52
Home Occupation	A	A	A	Chapter 17.96.040
Temporary Uses and Structures	M	M	-	Section 17.96.190
Urban Agriculture				
Home Gardens	P	P	P	

Attachment: Part 1 and Part 2 Draft Zoning Code PC Redlines (1512 : Zoning Code Update)



Key	Zoning District			Additional Regulations
	R-1	RM	MH	
P Permitted Use				
A Administrative Permit required				
M Minor Use Permit required				
C Conditional Use Permit required				
- Use not allowed				
Community Gardens	M	M	M	
Urban Farms	C	C	C	

Notes:

- [1] May include offices incidental and necessary to conduct a mobile home park use.
- [2] Permitted on the mobile home park parcel or on a separate parcel of no less than 5,000 square feet.
- [3] An accessory structure that exceed the development standards of Chapter 17.52 requires a Conditional Use Permit.

**B. Additional Permits.** In addition to permits identified in Table 17.16-1, development projects in the residential zoning districts may also require a Design Permit pursuant to Chapter 17.120 (Design Permits). Modifications to a historic resource may require a Certificate of Appropriateness pursuant to Chapter 17.84 (Historic Preservation).

**17.16.030 Development Standards**

**A. General Standards - Single-Family and Multi-Family Zoning Districts.** Table 17.16-2 identifies development standards that apply in the R-1 and RM zoning districts.

**TABLE 17.16-2: DEVELOPMENT STANDARDS IN THE R-1 AND RM ZONING DISTRICTS**

	R-1	RM	Additional Standards
<b>Site Requirements</b>			
Parcel Area, Minimum <a href="#">[1]</a>	5,000 sq. ft.	N/A	
Parcel Width, Minimum <a href="#">[1]</a>	30 ft.	N/A	
Parcel Depth, Minimum <a href="#">[1]</a>	80 ft.	N/A	
Floor Area Ratio, Maximum	See Section 17.16.030.B.1	N/A	17.16.030.B 17.48.040
Parcel Coverage, Maximum	N/A	40%	
Parcel Area Per Unit, Minimum	N/A	<u>RM-L</u> : 4,400 sq. ft. <u>RM-M</u> : 2,900 sq. ft. <u>RM-H</u> : 2,200 sq. ft.	
Parking and Loading	See Chapter 17.76		
<b>Structure Requirements</b>			
Setbacks, Minimum			17.48.030
Front	<u>Ground floor</u> : 15 ft. <u>Garage</u> : 20 ft. <u>Second story</u> : 20 ft.	15 ft.	<a href="#">17.16.030.B.3</a> <a href="#">Garage Setback</a>
Rear	20% of parcel depth; 25 ft. max.	15% of parcel depth	

Attachment: Part 1 and Part 2 Draft Zoning Code PC Redlines (1512 : Zoning Code Update)

	R-1	RM	Additional Standards
Interior Side	<u>Ground floor</u> : 10% of parcel width; 3 ft. min.; 7 ft. max. <u>Second story</u> : 15% of parcel width	10% of parcel width	17.16.030.B. 4&5
Street Side, Corner Lots	10 ft.	10 ft.	17.16.030.B.3
Height, Maximum	25 ft.	<u>RM-L</u> : 30 ft. <u>RM-M</u> : 30 ft. <u>RM-H</u> : 35 ft.	17.16.030.B.6 & 7 17.48.020
Accessory Structures	See Chapter 17.52		

Notes:

[1] Parcel area, width, and depth requirements apply only to the creation of new parcels. These requirements do not apply to legally created parcels existing as of [effective date of updated Zoning Code]. See Capitola Municipal Code Title 16 (Subdivisions) for requirements that apply to lot line adjustments to existing parcels that do not comply with the parcel area, width, and depth requirements in this table.

**B. Additional Standards in the R-1 Zoning District.** The following additional standards apply in the R-1 zoning district.

1. **Floor Area Ratio.** Table 17.16-3 identifies the maximum permitted floor area ratio (FAR) in the R-1 zoning district.

**TABLE 17.16-3: MAXIMUM FLOOR AREA RATIO IN THE R-1 ZONING DISTRICT**

Lot Size	Maximum FAR
2,650 sq. ft. or less	0.58
2,651 to 3,250 sq. ft.	0.57
3,251 to 3,500 sq. ft.	0.56
3,501 to 3,750 sq. ft.	0.55
3,751 to 4,000 sq. ft.	0.54
4,001 to 4,250 sq. ft.	0.53
4,251 to 4,500 sq. ft.	0.52
4,501 to 4,750 sq. ft.	0.51
4,751 to 5,000 sq. ft.	0.50 [1]
5,001 to 6,000 sq. ft.	0.49 [1]
More than 6,000 sq. ft.	0.48 [1]

Notes:

[1] Parcels of 5,000 sq. ft. or more with approved second dwelling units are permitted a maximum FAR of 0.60 for all structures.

2. **Front Setbacks in Riverview Terrace.** Within the areas shown in Figure 17.16-1, the Planning Commission may approve a reduced front setback to reflect existing

front setbacks on neighboring properties within 100 feet on the same side of the street. The reduced front setback shall in all cases be no less than 10 feet.



**Note:** In the existing Zoning Code minimum front setbacks in Riverview Terrace may be reduced to the average of lots on same side of street within 500 feet of the subject property to a maximum of 10 feet. Paragraph 2 above allows minimum setbacks to be reduced to reflect existing front setbacks on neighboring properties on the same side of the street.

FIGURE 17.16-1: RIVERVIEW TERRACE

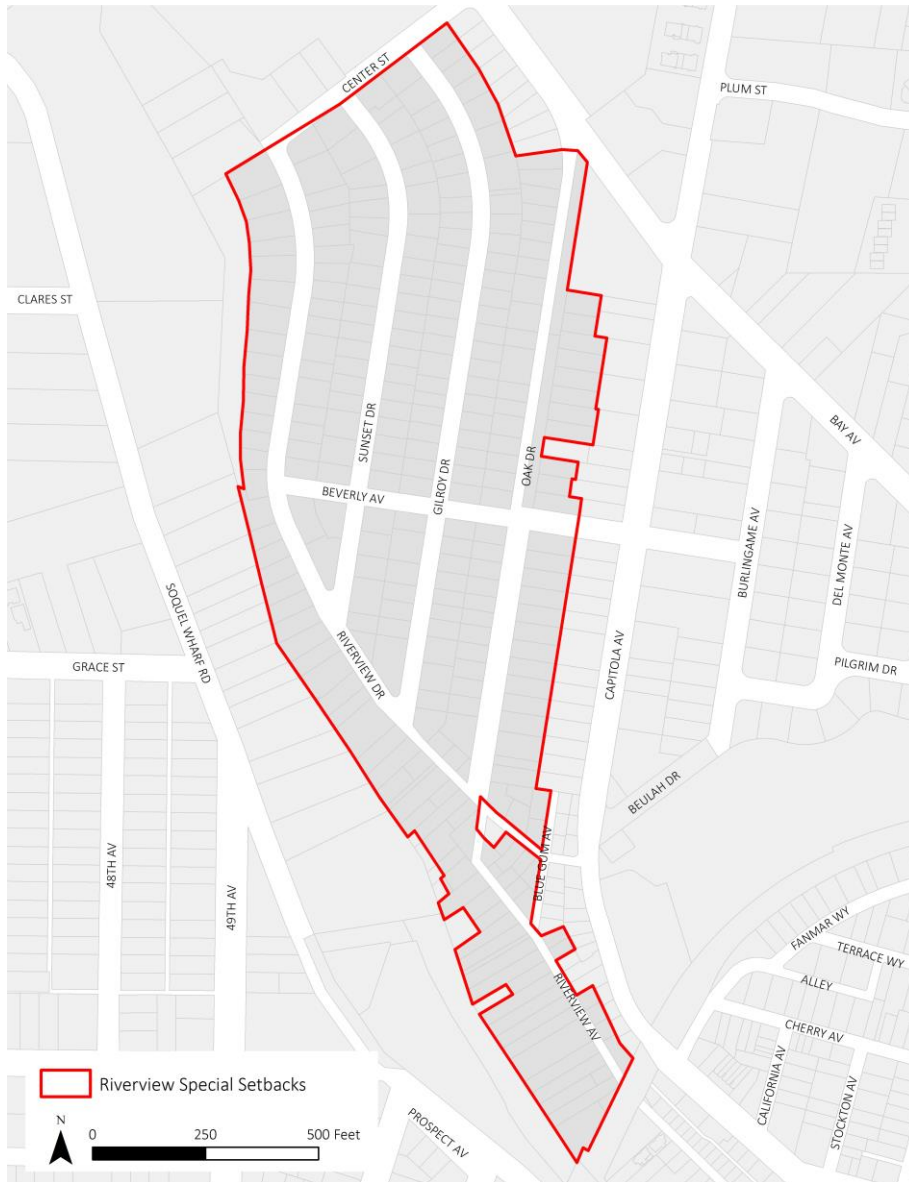

3. Garage Setbacks.

Attachment: Part 1 and Part 2 Draft Zoning Code PC Redlines (1512 : Zoning Code Update)

- a. Attached garages shall be setback a minimum of 5 feet behind the front or street side building wall of the primary structure. The Planning Commission may reduce this minimum setback to 3 feet in sidewalk exempt areas.
  - b. Required setbacks for detached garages are identified in Chapter 17.52 (Accessory Structures).
4. **Corner Lots.** The minimum rear setback for reserve corner lots shall be the minimum interior side yard of the adjacent property, but no less than 4 feet. See Figure 17.16-2.

FIGURE 17.16-2: REVERSE CORNER LOT REAR SETBACK

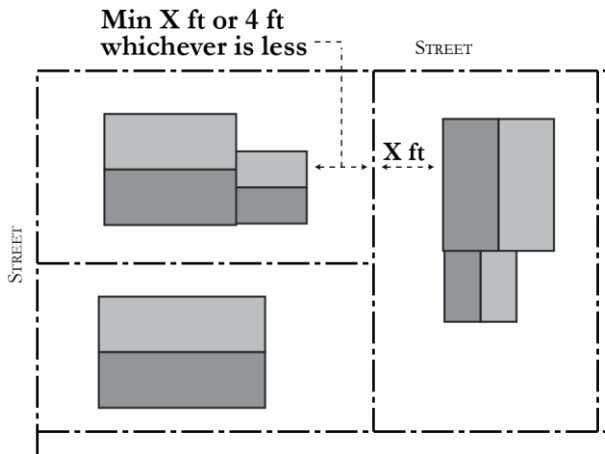

5. **Second Story Setback Exceptions.** Second story additions must comply with increased setback requirements in Table 17.16-2, except in the following cases:
- a. For lots 30 feet wide or less, the minimum interior side setback for a second story is the same as for the ground floor.
  - b. Up to 20 percent of the length of an upper story wall may be constructed at the same setback as the first-floor wall if the first-floor wall is at least 4 feet from the side property line. See Figure 17.16-3.

FIGURE 17.16-3: SECOND STORY SETBACK EXCEPTION

Attachment: Part 1 and Part 2 Draft Zoning Code PC Redlines (1512 : Zoning Code Update)

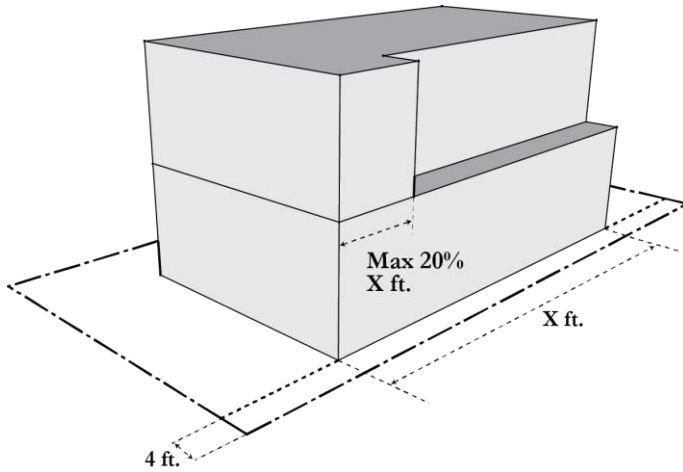

**Note:** R-1 height exceptions in Paragraph 6 below are new.

6. **Height Exceptions.** A maximum height of up to 27 feet in the R-1 zoning district is allowed in the following circumstances:
- a. Additions to historic structures that is designed to match the roof pitch of the historic structure within the area of new addition.
  - b. Parcels greater than 6,000 sf in size.
  - c. Parcels with a width 60 feet or more.
  - d. Parcels with an average slope of 25 percent or greater.
  - e. When the plate height of structure does not exceed 22 feet.
  - f. ~~Plate Height in Side Setback Areas. For portions of a building with four feet or less from an interior side property line, the maximum wall plate height is 12 feet. See Figure 17.16-4.~~

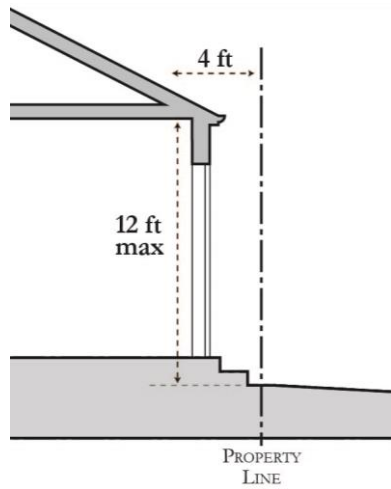
**FIGURE 17.16-4: MAXIMUM PLATE HEIGHT**

**Note:** Standards in Paragraph 8 below to allow decks and balconies with an Administrative Permit instead of a Design Permit are new.

**C.—7. Decks and Balconies.**

- 1.—~~Upper floor decks and balconies immediately adjacent to a street or public open space are allowed with an Administrative Permit and do not require a Design Permit. All other decks and balconies require Planning Commission approval of a Design Permit. on the side or rear of a residential structure that are not adjacent to public open space are allowed with an Administrative Permit if the deck or balcony is:~~
- 2.—~~Located 10 feet or more from property line and 20 feet or more from another single family dwelling; and~~
- 3.—~~Does not directly face a window, balcony, patio, or other usable open space of another single family dwelling.~~
- 4.7.—~~Decks and balconies that do not meet standards (1) and (2) above require Planning Commission approval of a Design Permit.~~

**D.C. Additional Standards for RM Zoning Districts.** The following additional standards apply in the RM zoning district.

1. **Single-Family Dwellings.** Single-family dwellings in RM zoning districts shall comply with the development standards that apply in the R-1 zoning district.
2. **Open Space.** Common and private open space in the RM zoning district shall be provided as shown in Table 17.16-4.

**TABLE 17.16-4: USABLE OPEN SPACE IN RM ZONING DISTRICT**

<b>Common Open Space [1]</b>	
Minimum area (percent of site area)	15% [2] [3]
Minimum horizontal dimension	15 ft.
<b>Private Open Space [4]</b>	
Minimum percentage of units with private open space	50%
Minimum area (for individual unit)	48 sq. ft.
Minimum horizontal dimension	4 ft.

Notes:

- [1] Common open space shall be fully landscaped and accessible to all residents.
- [2] Roof terraces and roof gardens may provide up to 50 percent of the required common open space area if the Planning Commission finds that roof terraces and roof gardens provide quality open space for residents and minimize noise, privacy and other potential impacts on neighboring properties.
- [3] The Planning Commission may allow reduced common open space to a minimum of 10 percent for projects less than one acre in size or for projects that provide additional private open space equal to or greater than the amount of reduced common open space.
- [4] Private open space may include screened terraces, decks, balconies, and other similar areas



**Note:** The existing Zoning Code requires 50 percent of the required rear yard to be developed as common open space. Subsection C above requires 15 percent of the site area to be common open space. Ability to reduce common open space is new to provide flexibility for smaller infill projects.

**E.D. Standards for the MH Zoning District.** Table 17.16-5 identifies development standards that apply in the Mobile Home (MH) zoning district.

Attachment: Part 1 and Part 2 Draft Zoning Code PC Redlines (1512 : Zoning Code Update)

**TABLE 17.16-5 MH ZONING DISTRICT DEVELOPMENT STANDARDS**

		Additional Standards
Site Area [1]	5 acres [2]	
Residential Density, Maximum	20 units per acre	
Setbacks [3]		17.48.030
Front	15 ft.	
Interior Side	10 ft.	
Exterior Side	10 ft.	
Rear	20 ft.	

Notes:

[1] Applies to overall mobile home park area, not sites for individual units.

[2] For vacant property rezoned to MH, the minimum lot area is 5 acres. For existing mobile home parks, the minimum parcel size is 5 acres or the existing parcel size, whichever is less.

[3] Applies only to the perimeter of the mobile home park, not to sites and structures within the interior of the park.



**Note:** Minimum setbacks for the perimeter of the mobile home park in Table 17.16-5 above are new.



## Chapter 17.20 – MIXED USE ZONING DISTRICTS

### Sections:

17.20.010 Purpose of the Mixed Use Zoning Districts

17.20.020 Land Use Regulations

17.20.030 Development Standards – Mixed Use Village Zoning District

17.20.040 Development Standards – Mixed Use Neighborhood Zoning District

~~17.20.010 Purpose of the Mixed Use Zoning Districts~~

~~17.20.020 Land Use Regulations~~

~~17.20.030 Development Standards~~

### ~~17.20.040~~17.20.010 Purpose of the Mixed Use Zoning Districts

**A. General.** The purpose of the mixed use zoning districts is to provide for active and inviting destinations in Capitola with a diversity of residential and commercial land uses. In the mixed use zoning districts development supports a lively, pedestrian-friendly public realm with inviting storefronts facing the sidewalk. A diversity of local and independent businesses, recreational amenities, and public spaces balance the needs of residents and visitors. New development respects Capitola's history and reflects its unique coastal village character. The diversity of land uses, pedestrian-friendly development, and general level of activity in the mixed use zoning districts supports a range of transportation choices, including walking, biking, and transit.

### **B. Specific.**

- ~~Village~~**Mixed Use, Village (MU-V) Zoning District.** The purpose of the MU-V zoning district is to preserve and enhance Capitola Village as the heart of the community. A diversity of commercial, residential, and recreational uses in the MU-V zoning district serve both visitors and residents. Land uses and development enhance the vitality of the Village while maintaining a high quality of life for residents. A fine-grain mix of retail, restaurants, services, and recreational amenities in the MU-V zoning district cater to all ages and support year-round activity during the day and night.
- ~~Neighborhood~~**Mixed Use, Neighborhood (MU-N) Zoning District.** The purpose of MU-N zoning district is to allow for neighborhood-serving mixed use areas that enhance residents' quality of life. The MU-N zoning districts contain an eclectic mix of retail, restaurants, and services for residents and visitors. A range of housing types close to non-residential uses increases housing choices and supports a walkable community. Development in the MU-N zoning district ~~is~~will be carefully designed to complement its surroundings and minimize impacts on neighboring properties. Land uses strengthen connections between destinations in Capitola, including the Village, Bay Avenue, and 41<sup>st</sup> Avenue.

### ~~17.20.050~~17.20.020 Land Use Regulations

**A. Permitted Land Uses.** Table 17.20-1 identifies land uses permitted in the mixed use zoning districts.



**Note:** Permitted land uses in the mixed use zoning districts have been revised to better reflect the purpose of the zoning districts. New Minor Use Permit required for uses that need discretionary review but may not need a Planning Commission hearing.

**TABLE 17.20-1: PERMITTED LAND USES IN THE MIXED USE ZONING DISTRICTS**

Key P Permitted Use A Administrative Permit required M Minor Use Permit required C Conditional Use Permit required - Use not allowed	Zoning District		Additional Regulations
	MU-V	MU-N	
<b>Residential Uses</b>			Section 17.20.020.B & C
Duplex Homes	P/C [1]	P	
Elderly and Long Term Care	C	C	
Group Housing	C	C	
Multi-Family Dwellings	P/C [1]	C	
Residential Care Facilities, Small	C	P	
Residential Care Facilities, Large	C	C	Section 17.96.080
Residential Mixed Use	See Section 17.20.020.D	C	
Secondary Dwelling Units	<del>MA</del>	<del>AM</del>	Chapter 17.74
Single-Family Dwellings	C [3]	P	
<b>Public and Quasi-Public Uses</b>			
Community Assembly	C	C	
Cultural Institutions	C	C	
Day Care Centers	M	M	
Government Offices	P/C [1]	M	
Home Day Care, Large	M	M	Section 17.96.070
Home Day Care, Small	P	P	
Medical Offices and Clinics	-	M	
Parks and Recreational Facilities	C	C	
Public Safety Facilities	C	C	
Schools, Public or Private	-	C	
<b>Commercial Uses</b>			
Alcoholic Beverage Sales	C	C	
Banks and Financial Institutions	C	P [2]	
Commercial Entertainment and Recreation	C	C	
Eating and Drinking Places			
Bars and Lounges	C	C	
Restaurants and Cafes	C	C	
Take-Out Food and Beverage	M	M	
Gas and Service Stations	-	-	
<b>Lodging</b>			
Bed and Breakfast	C	C	
Hotels and Motels	C	C	

Attachment: Part 1 and Part 2 Draft Zoning Code PC Redlines (1512 : Zoning Code Update)

Key	Zoning District		
	MU-V	MU-N	Additional Regulations
P Permitted Use			
A Administrative Permit required			
M Minor Use Permit required			
C Conditional Use Permit required			
- Use not allowed			
Personal Services	P	P [2]	
Professional Offices	P/C [1]	M	
Retail	P	P [2]	
Vacation Rental	See Chapter 17.40.030		
<b>Transportation, Communication, and Utility Uses</b>			
Utilities, Major	C	C	
Utilities, Minor	P	P	
Wireless Communications Facilities	See Chapter 17.104		
<b>Other Uses</b>			
Accessory Uses and Structures	See Chapter 17.52		Chapter 17.52
Home Occupations	A	A	Section 17.96.040
Temporary Uses and Structures	See Section 17.96.170		
<b>Urban Agriculture</b>			
Home Gardens	P	P	
Community Gardens	M	M	
Urban Farms	C	C	

Notes:

- [1] Second and third floor uses permitted by-right. Ground floor uses require a Conditional Use Permit.
- [2] Larger than 3,000 sq. ft. requires a Conditional Use Permit.
- [3] Permitted by-right in the Village Residential overlay zone

**B. Village Residential Overlay.** Pursuant to Section 17.40.040 (Village Residential (-VR) Overlay Zone), only residential uses are permitted in the -VR overlay zone. The Village Residential (-VR) overlay zone applies to the following areas within the MU-V zoning district as shown on the Zoning Map: Six Sisters, Venetian Court, Wharf Road, Lawn Way, Riverview Avenue, Cliff Drive, ~~and~~ Cherry Avenue, San Jose Avenue, Park Place, and California Avenue.

**C. Ground Floor Conversions to Residential.** Existing ground floor commercial uses in the MU-V zoning district may not be converted to a residential use unless located in the Village Residential (-VR) overlay zone.

**D. Residential Mixed Use in the MU-V Zoning District.**

1. If a proposed residential mixed use project in the MU-V zoning district contains any use that requires a Conditional Use Permit, the entire project, including the residential use, requires a Conditional Use Permit.
2. If a proposed residential use replaces an existing upper floor commercial use, the residential use is allowed by-right.

~~17.20.060~~ **17.20.030** Development Standards – Mixed Use Village Zoning District

A. **General.** Table 17.20-2 identifies development standards that apply in the ~~m~~**Mixed** ~~u~~**Use Village (MU-V)** zoning districts.



**Note:** Minimum parcel dimensions area and maximum front setbacks in Table 17-20-2 below are **new**.

TABLE 17.20-2: DEVELOPMENT STANDARDS IN THE MIXED USE **VILLAGE (MU-V)** ZONING DISTRICTS

	<del>Zoning District</del>  MU-V  MU-N	Additional Standards
<b>Site Requirements</b>		
Floor Area Ratio, Maximum	2.0	<a href="#">Section 17.20.030.CE</a> <a href="#">Chapter 17.88</a>
Parking and Loading	See Chapter 17.76	
<b>Structure Requirements</b>		
Setbacks		
Front	<u>Min:</u> 0 ft. <u>Max:</u> 15 ft.	Section 17.20.030.D
Rear	None <del>[12]</del>	
Interior Side	None	
Street Side	<u>Min:</u> 0 ft. <u>Max:</u> 15 ft.	
Height, Maximum	27 ft.	Section 17.20.030.B & C Section 17.48.020 <a href="#">Chapter 17.88</a>
Accessory Structures	See Chapter 17.52	

Notes:

- [1] 20% of lot depth for residential use on parcel.
- ~~[2] The Planning Commission may approve reduced front, side, and rear setback requirements for properties fronting Capitola Avenue north of the trestle up to and including 431 Capitola Avenue.~~
- ~~[3] The Planning Commission may reduce front, side, and rear setbacks when a parcel is adjacent to commercial along the side and rear property lines and when the parcel width or depth is significantly less than typical parcels within the zoning district.~~



**Note:** MU-V height exceptions to allow up to 30 feet in subsection B below are new.

B. ~~MU-V~~ **Height Exceptions.** The following exceptions are permitted to the maximum permitted height in the MU-V zoning district as shown in Table 17.20-2:

Attachment: Part 1 and Part 2 Draft Zoning Code PC Redlines (1512 : Zoning Code Update)

1. Up to 30 feet for habitable space with a roof pitch of at least 5/12. See Figure 17.20-1.
2. Projections for non-habitable decorative features and structures as allowed by Section 17.48.030.C

**FIGURE 17.20-1: INCREASED HEIGHT IN THE MU-V ZONING DISTRICT**

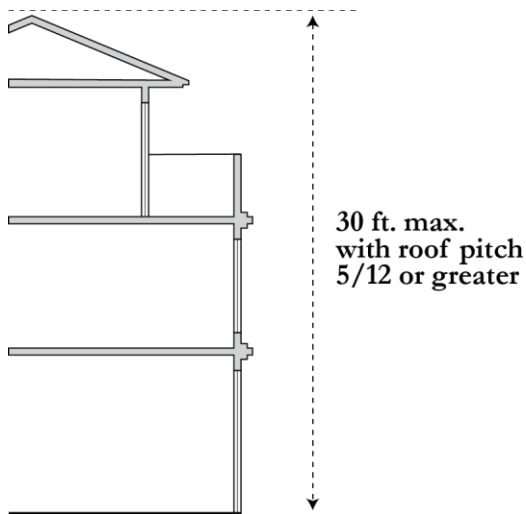

**C. Increased Floor Area And Height for the Capitola Theater Site.** As provided in Chapter 17.88 (Incentives for Community Benefits), the City Council may approve exceptions to height and floor area ratio (FAR) limits shown in Table 17.20-2 for the Capitola Theater site (APN 035-262-04). These exceptions are intended to facilitate the development of a new hotel in the Capitola Village consistent with the General Plan.

**Note:** Minimum build-to requirements in the MU-V zoning district in subsection D below are new.

**D. Setbacks in the MU-V Zoning District.** The following setback standards apply to all new structures in the MU-V zoning district.



1. Building should be constructed within 15 feet of the front property line for a minimum of 50 percent of the parcel’s linear street frontage. See Figure 17.20-7. The Planning Commission may modify or waive this requirement upon finding that:
  - a. Compliance with the build-to width requirement would render the proposed project infeasible;
  - b. The project incorporates a front-facing courtyard of public seating area; or
  - c. An alternative site design would result in an enhanced pedestrian experience.

**FIGURE 17.20-7: BUILD TO LINE – MU-V ZONING DISTRICT**

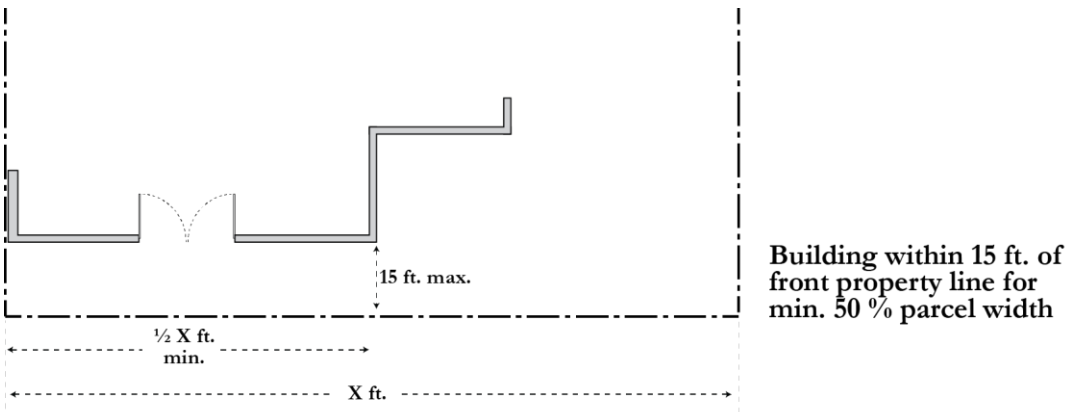

2. Front setback areas shall be pedestrian oriented and contain semi-public amenities such as courtyards or outdoor seating areas.
3. Structures shall be setback a minimum of 10 feet from the property line on the northerly side of the first two hundred fifty feet of Cliff Drive, west of the intersection of Wharf Road.



**Note:** Design standards for the ~~M~~ixed ~~u~~se Village zoning districts in subsection C below are new.

**C.E.** **General Design Standards.** The following standards apply to all new buildings and additions ~~with~~in the MU-V ~~and MU-N~~ zoning districts, excluding the Village Residential Overlay.

1. **Building Orientation.** Buildings shall be oriented towards a public street with the primary entrance to the site or building directly accessible from an adjacent sidewalk. See Figure 17.20-2.

**FIGURE 17.20-2: BUILDING ORIENTATION**

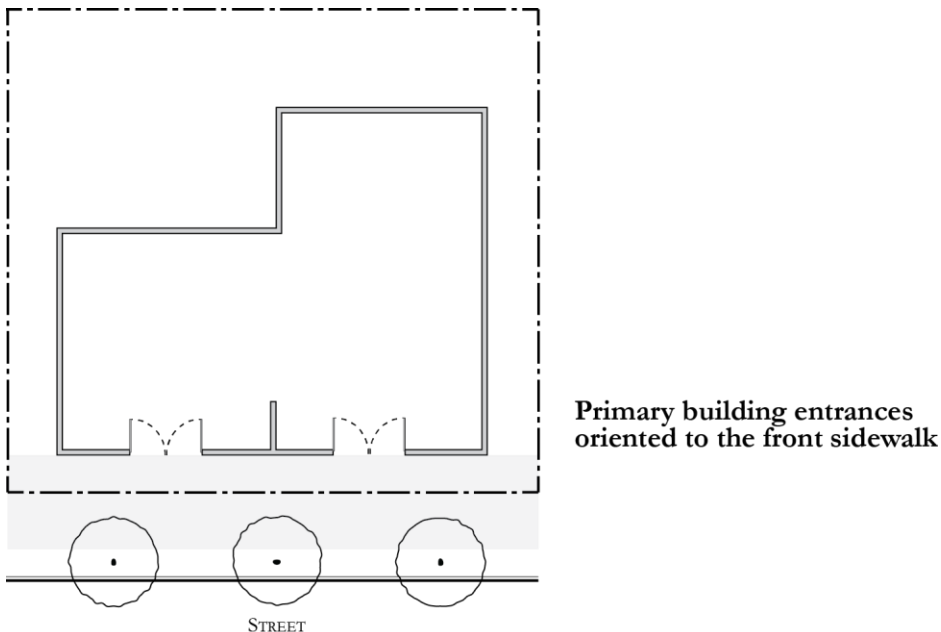

2. **Blank Walls.** The maximum length of an unarticulated/blank building wall fronting a public street shall be 10 feet. See Figure 17.20-3. Building articulation may be provided by:
  - a. Doors, windows, and other building openings;
  - b. Building projections or recesses, doorway and window trim, and other details that provide architectural articulation and design interest;
  - c. Varying wall planes, heights or contrasting materials and colors; and
  - d. Awnings, canopies or arcades to reinforce the pedestrian scale and provide shade and cover from the elements.

**FIGURE 17.20-3: BLANK WALL LIMITATIONS**

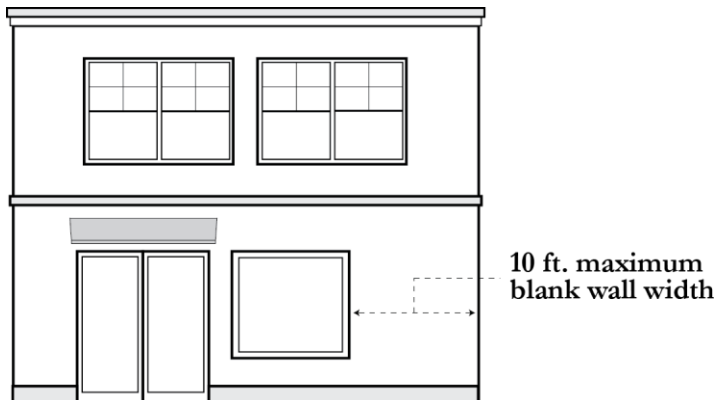

Attachment: Part 1 and Part 2 Draft Zoning Code PC Redlines (1512 : Zoning Code Update)



- 3. **Storefront Width.** The maximum building/storefront width shall be 25 feet. See Figure 17.20-4. Larger buildings shall be broken down into a pedestrian-scale rhythm with individual building bay widths of 25 feet.

FIGURE 17.20-4: STOREFRONT WIDTH

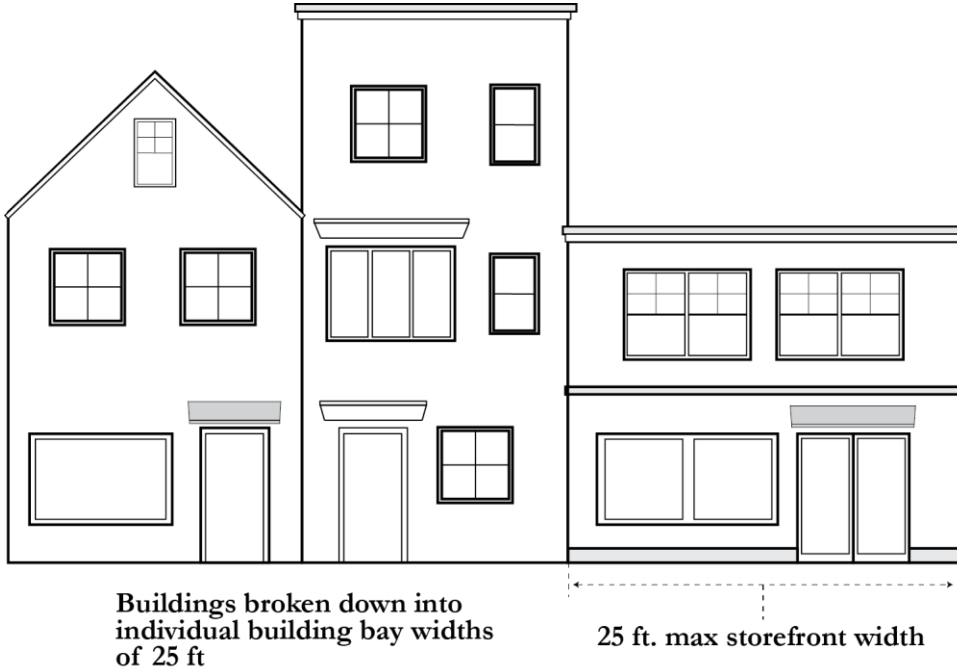

- 4. **Ground Floor Building Transparency.**
  - a. The ground floor street-facing building walls of non-residential uses shall provide transparent windows or doors with views into the building for a minimum of 65 percent of the building frontage located between 2½ and 7 feet above the sidewalk. See Figure 17.20-5. Ninety percent of the transparent windows or doors area shall remain clear to allow views into the building.

FIGURE 17.20-5: STOREFRONT TRANSPARENCY



Attachment: Part 1 and Part 2 Draft Zoning Code PC Redlines (1512 : Zoning Code Update)

- b. Exceptions to this transparency requirement may be allowed with a Design Permit if the Planning Commission finds that:
  - (1) The proposed use has unique operational characteristics which preclude building openings, such as for a cinema or theatre; and
  - (2) Street-facing building walls will exhibit architectural relief and detail, and will be enhanced with landscaping in such a way as to create visual interest at the pedestrian level.

**5. Parking Location and Buffers.**

- a. Surface parking shall be located to the rear or side of buildings. Surface parking may not be located between a building and a street-facing property line. See Figure 17.20-6.
- b. Surface parking adjacent to a street-facing property line shall be screened along the public right-of-way with a decorative wall, hedge, trellis, and/or landscaping at least 3 feet in height.
- c. Loading areas shall be located to the side and rear of buildings, and shall be sufficiently screened from the public right-of-way, as determined by the Community Development Director.

**FIGURE 17.20-6: PARKING LOCATION**

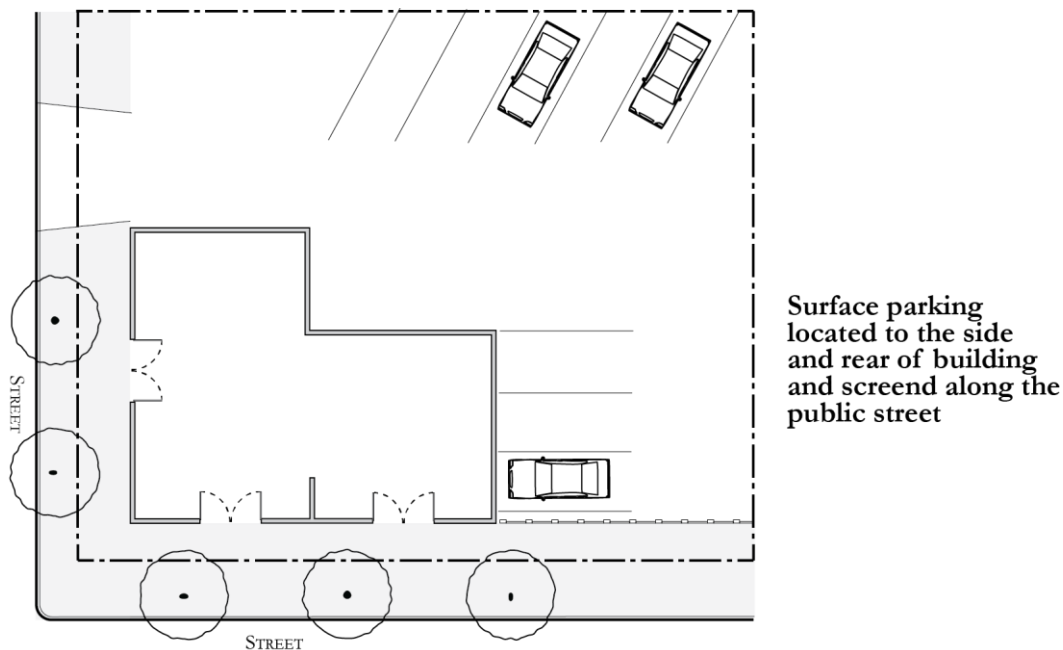

**6. Driveways and Curb Cuts.**

- a. New driveways shall comply with the dimension standards shown in Table 17.20-3 (Driveway Dimension Standards). The Community Development Director may approve exceptions to these standards in the case of shared or joint use of driveways and parking lots.

**TABLE 17.20-3: DRIVEWAY DIMENSION STANDARDS**

Driveway Type	Driveway Width	
	Minimum	Maximum
1-way	8 ft.	12 ft.[1]
2-way	20 ft.	25 ft. [1].

Note: [1] Driveways shall not exceed 40% of parcel width.

b. New curb cuts, where allowed, shall be located and designed to maximize safety and convenience for pedestrians, bicycles and mass transit vehicles, as determined by the Community Development Director.

7. Paved Site Areas.

a. The materials, colors, textures, and other design features of on-site paved areas, including courtyards, walkways, and patios, shall complement and enhance the overall design character of development on the site.

b. The use of asphalt for on-site paving is prohibited, except when used for parking areas and vehicle circulation.

~~D.~~

Attachment: Part 1 and Part 2 Draft Zoning Code PC Redlines (1512 : Zoning Code Update)



~~Note: Minimum build-to requirements in the MU-V zoning district in subsection D below are new.~~

~~**Setbacks in the MU-V Zoning District.** The following setback standards apply to all new structures in the MU-V zoning district.~~

~~Building shall be constructed at within 15 feet of the front property line for a minimum of 50 percent of the parcel's linear street frontage. See Figure 17.20-7. The Planning Commission may modify or waive this requirement upon finding that:~~

~~Compliance with the build-to width requirement would render the proposed project infeasible;~~

~~The project incorporates a front-facing courtyard of public seating area; or~~

~~An alternative site design would result in an enhanced pedestrian experience.~~

~~FIGURE 17.20-7: BUILD-TO LINE — MU-V ZONING DISTRICT~~

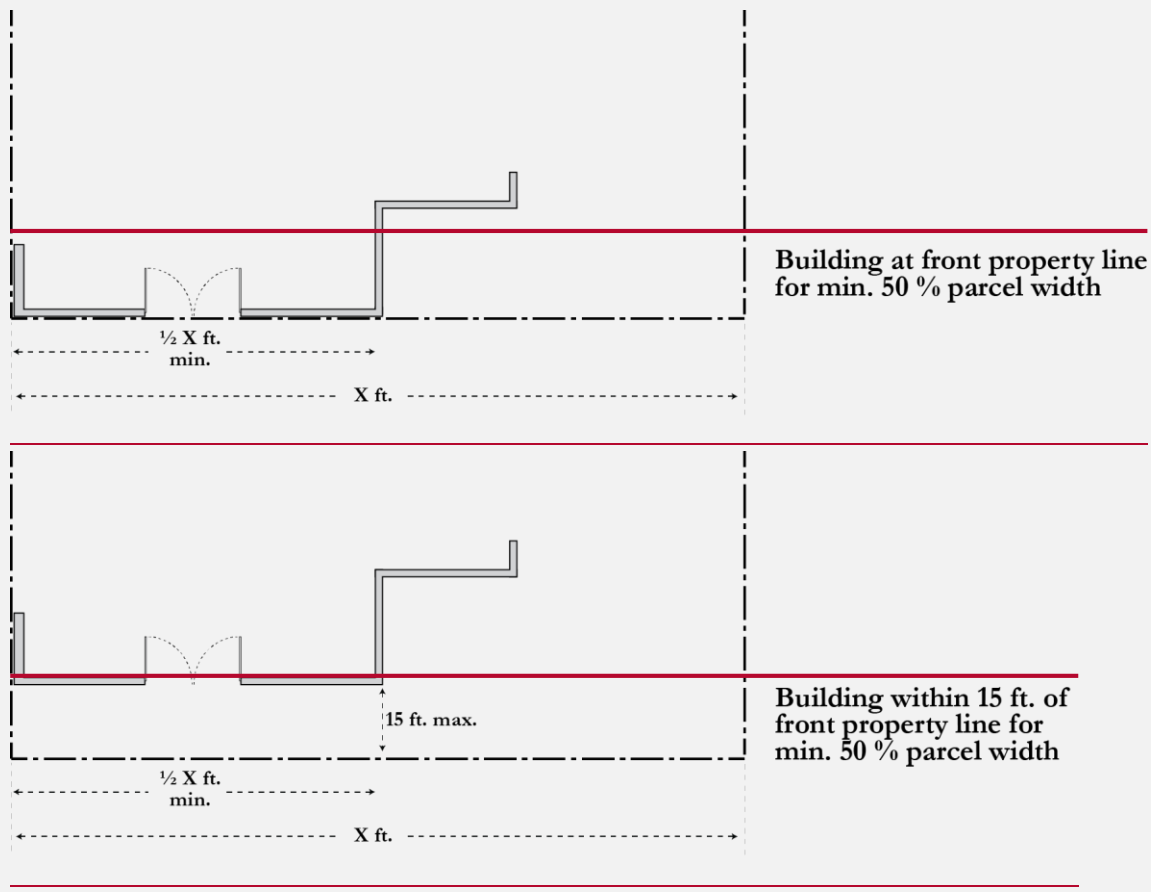

~~Front setback areas shall be pedestrian oriented and contain semi-public amenities such as courtyards or outdoor seating areas.~~

~~Structures shall be setback a minimum of 10 feet from the property line on the northerly side of the first two hundred fifty feet of Cliff Drive, west of the intersection of Wharf Road.~~

~~**E.A. Setbacks in the MU-N Zoning District.** Front setback areas in the MU-N Zoning District shall be pedestrian oriented and shall be either landscaped or contain semi-public amenities such as courtyards or outdoor seating areas.~~



**Note:** Height and FAR standards exception for the Village hotel are new to implement General Plan policies.

~~**F. Height and FAR Standards for the Village Capitola Theater Site.** As provided in Chapter 17.88 (Incentives for Community Benefits), Hotel~~

~~**G. General.** The City Council may approve exceptions to height and floor area ratio (FAR) limits shown in Table 17.20-2 for a hotel on the former Village Capitola Theater site (APN 035-262-04) in the MU-V zoning district. These exceptions are intended to facilitate the development of a new hotel in the Capitola Village consistent with the General Plan.~~

~~Maximum FAR. The City Council may allow a maximum FAR of 3.0 for a proposed hotel on the former Village Capitola Theater site.~~

~~Height. The City Council may allow an exception to the 27-foot height limit for a proposed hotel on the former Village Capitola Theater site, provided that:~~

~~The maximum height of the hotel remains below the elevation of the bluff behind the hotel; and  
The bluff behind the hotel remains visible from the Capitola wharf as a green edge with existing mature trees maintained on site.~~

~~Basis for Approval. To approve increased FAR and/or height, the City Council must make all of the following findings:~~

~~The design of the hotel respects the scale and character of neighboring structures and enhances Capitola's unique sense of place.~~

~~The additional height and/or FAR allows for a superior project with substantial community benefit.  
The hotel will contribute to the economic vitality of the Village and support an active, attractive, and engaging pedestrian environment.~~

~~The hotel design minimizes impacts to public views of the beach and Village from vantage points outside of the Village.~~

~~Parking for the hotel is provided in a way that minimizes vehicle traffic in the Village and strengthens the Village as a pedestrian oriented destination.~~

~~The project is designed to minimize adverse impacts to neighboring properties to the greatest extent possible.~~

**17.20.040 Development Standards – Mixed Use Neighborhood Zoning District**

**A. General.** Table 17.20-42 identifies development standards that apply in the Mixed Use Neighborhood (MU-N) zoning districts.

**Note:** Minimum parcel dimensions and maximum front setbacks in Table 17-20-2 below are new.



**TABLE 17.20-42: DEVELOPMENT STANDARDS IN THE MIXED USE ZONING DISTRICTS**

	Zoning District	Additional Standards
	MU-N	
<b>Site Requirements</b>		
Parcel Area, Minimum [1]	3,200 sq. ft.	
Parcel Width, Minimum [1]	40 ft.	
Parcel Depth, Minimum [1]	80 ft.	
Floor Area Ratio, Maximum	1.0	
Parking and Loading	See Chapter 17.76	
<b>Structure Requirements</b>		
<b>Setbacks</b>		
Front	Min: 0 ft. from property line or 10 ft. from curb, whichever is greater Max: 25 ft.	Section 17.20.0340.CD
Rear	10 ft. min. from property line [2] [3] [4]	
Interior Side	10% of lot width [3] [4]	
Street Side	Min: 0 ft. from property line or 10 ft. from curb, whichever is greater Max: 25 ft.	
Height, Maximum	27 ft.	Section 17.20.0430.B Section 17.48.0420.D
Accessory Structures	See Chapter 17.52	

**Notes:**

[1] Parcel area, width, and depth requirements apply only to the creation of new parcels. These requirements do not apply to legally created parcels existing as of [effective date of updated Zoning Code]. See Capitola Municipal Code Title 16 (Subdivisions) for requirements that apply to lot line adjustments to existing parcels that do not comply with the parcel area, width, and depth requirements in this table.

[2] 20% of lot depth for residential use on parcel.

[3] The Planning Commission may approve reduced front, side, and rear setback requirements for properties fronting Capitola Avenue north of the trestle up to and including 431 Capitola Avenue.

[4] The Planning Commission may reduce front, side, and rear setbacks when a parcel is adjacent to commercial along the side and rear property lines and when the parcel width or depth is significantly less than typical parcels within the zoning district.

**B. Building Orientation.**

- Buildings shall be oriented towards a public street with the primary entrance to the site or building directly accessible from an adjacent sidewalk.

Attachment: Part 1 and Part 2 Draft Zoning Code PC Redlines (1512 : Zoning Code Update)

2. The Planning Commission may grant an exception to the requirement in paragraph 1 above upon finding that unique conditions on the site require an alternative building orientation and that the proposed project would maintain a pedestrian-friendly and active street frontage to the greatest extent possible.

**C. Setbacks in the MU-N Zoning District.** Front setback areas in the MU-N Zoning District not used for vehicle parking or circulation shall be pedestrian oriented and shall be either landscaped or contain semi-public amenities such as courtyards or outdoor seating areas.

**D. Residential Transitions – Daylight Plane.** When a property abuts a residential zoning district, no structure shall extend above or beyond a daylight plane having a height of 25 feet at the setback from the residential property line and extending into the parcel at an angle of 45 degrees. See Figure 17.20-8.

**FIGURE 17.20-8: RESIDENTIAL TRANSITIONS – DAYLIGHT PLANE**

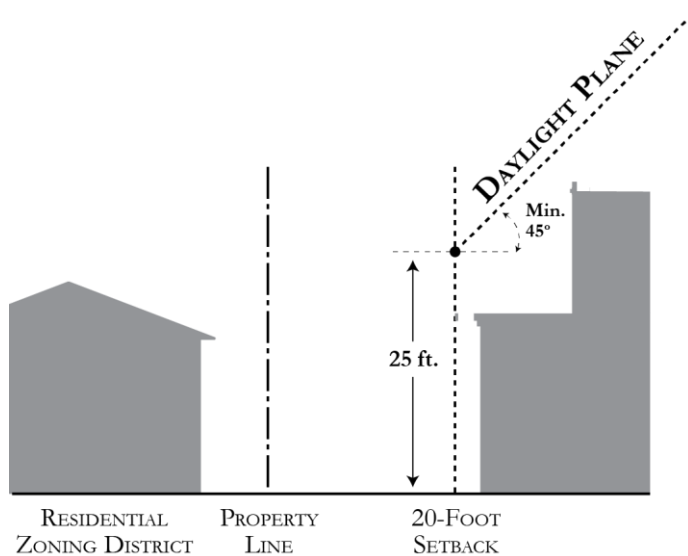

**E. Parking Location and Buffers.** Surface parking shall be located to the rear or side of buildings where possible. When parking is located between a building and a street-facing property line, the parking shall be either:

1. Screened along the street with a decorative wall, hedge, trellis, and/or landscaping at least 3 feet in height; or
2. Designed to minimize visual impacts and support a pedestrian-friendly environment to the greatest extent possible as determined by the Planning Commission.

**F. Driveways and Curb Cuts.**

1. New driveways shall comply with the dimension standards shown in Table 17.20-5 (Driveway Dimension Standards). The Community Development Director may

approve exceptions to these standards in the case of shared or joint use of driveways and parking lots.

**TABLE 17.20-5: DRIVEWAY DIMENSION STANDARDS**

<u>Driveway Type</u>	<u>Driveway Width</u>	
	<u>Minimum</u>	<u>Maximum</u>
<u>1-way</u>	<u>8 ft.</u>	<u>12 ft.[1]</u>
<u>2-way</u>	<u>20 ft.</u>	<u>25 ft. [1].</u>

Note: [1] Driveways shall not exceed 40% of parcel width.

- a. New curb cuts, where allowed, shall be located and designed to maximize safety and convenience for pedestrians, bicycles and mass transit vehicles, as determined by the Community Development Director. ~~Setbacks in the MU-N Zoning District. Front setback areas in the MU-N Zoning District not used for vehicle parking or circulation shall be pedestrian oriented and shall be either landscaped or contain semi-public amenities such as courtyards or outdoor seating areas.~~

Attachment: Part 1 and Part 2 Draft Zoning Code PC Redlines (1512 : Zoning Code Update)



## Chapter 17.24 – COMMERCIAL AND INDUSTRIAL ZONING DISTRICTS

### Sections:

- 17.24.010 Purpose of the Commercial and Industrial Zoning Districts
- 17.24.020 Land Use Regulations
- 17.24.030 Development Standards

### 17.24.010 Purpose of the Commercial and Industrial Zoning Districts

- A. Community Commercial (C-C) Zoning District.** The purpose of the C-C zoning district is to provide areas for a variety of commercial uses serving Capitola residents and visitors. The C-C zoning district allows for retail, restaurants, and services that meet the daily needs of the community. The scale, intensity, and design of development in the C-C zoning district is compatible with adjacent neighborhoods and contributes to Capitola's unique coastal village character. Interspersed residential and office uses in the C-C zoning district support a diverse local economy and range of housing choices.
- B. Regional Commercial (C-R) Zoning District.** The purpose of the C-R zoning district is to provide areas for commercial uses that serve regional shoppers as well as Capitola residents, workers, and visitors. The C-R zoning district maintains a critical mass of retail and service uses that maintain 41<sup>st</sup> Avenue as a successful retail destination. Office, medical, and residential uses are restricted ~~in prime retail locations~~ to protect the long-term economic vitality of the corridor. Incremental redevelopment of underutilized properties in the C-R zoning district enhance the corridor as a pedestrian-friendly shopping destination that enhance Capitola's unique identity and quality of life.
- C. Industrial (I) Zoning District.** The purpose of the I zoning district is to provide an area for heavy commercial and light industrial uses in Capitola. The I zoning district allows for non-residential uses which are desired in the community but could be incompatible with land uses in other zoning districts. The I zoning district accommodates businesses that contribute to a diverse economy, provide local jobs, and serve the needs of residents and other businesses in Capitola.

### 17.24.020 Land Use Regulations

- A. Permitted Land Uses.** Table 17.24-1 identifies land uses permitted in the commercial and industrial zoning districts.



**Note:** Permitted land uses in the commercial and industrial zoning districts have been revised to better reflect the purpose of the zoning districts. New Minor Use Permit required for uses that need discretionary review but may not need a Planning Commission hearing.

**TABLE 17.24-1: PERMITTED LAND USES IN COMMERCIAL AND INDUSTRIAL ZONING DISTRICTS**

Attachment: Part 1 and Part 2 Draft Zoning Code PC Redlines (1512 : Zoning Code Update)

Key P Permitted Use A Administrative Permit required M Minor Use Permit required C Conditional Use Permit required - Use not allowed	Zoning District			Additional Requirements
	C-C	C-R	I	
<b>Residential Uses</b>				
Multi-Family Dwellings	C	C [5]	-	
Residential Mixed Use	C	C	-	17.96.140
<b>Public and Quasi-Public Uses</b>				
Colleges and Trade Schools	C	C	C	
Community Assembly	C	C	-	
Cultural Institutions	C	C	-	
Day Care Centers	C	C	-	
Emergency Shelters	-	-	P	17.96.030
Government Offices	See 17.24.020.C		C	
Medical Offices and Clinics	See 17.24.020.C		-	
Public Safety Facilities	C	C	C	
<b>Commercial Uses</b>				
Alcoholic Beverage Sales	C	C	C	
Banks and Financial Institutions	P [2]	P [2]	-	
Business Services	P [2]	P [2]	P	
Commercial Entertainment and Recreation	M	M	-	
Drive-Through Facilities	<del>C [4]</del>	C [4]	-	
Eating and Drinking Establishments				
Bars and Lounges	C	C	-	
Restaurants and Cafes	M [2]	M [2]	-	
Take-Out Food and Beverage	M [2]	M [2]	-	
Food Preparation	M [2]		P	
Gas and Service Stations	C	C	-	
Liquor Stores	C	C	-	
Lodging				
Bed and Breakfast	C	-	-	
Hotel	C	C	-	
Maintenance and Repair Services	M	C	P	
Personal Services	P [1]	P [1]	-	
Professional Offices	See 17.24.020.C		P	
Salvage and Wrecking	-	-	P	
Self-Storage	C		C	17.96.150

Attachment: Part 1 and Part 2 Draft Zoning Code PC Redlines (1512 : Zoning Code Update)

Retail	P	P	-	
Vehicle Repair	C	C	P	
Vehicle Sales and Rental	C	C	-	
Wholesaling	-	M [3]	P	
<b>Heavy Commercial and Industrial Uses</b>				
Construction and Material Yards	-	-	P	
Custom Manufacturing	M	M	P	
Light Manufacturing	-	-	P	
Warehousing and Distribution	-	-	P	
<b>Transportation, Communication, and Utility Uses</b>				
Utilities, Major	-	C	C	
Utilities, Minor	P	P	P	
Recycling Collection Facilities	<u>C</u>	<u>C</u>	<u>C</u>	Section 17.976.130
Wireless Communications Facilities	See 17.104			
<b>Other Uses</b>				
Accessory Uses	See 17.52			
Home Occupations	A	A	-	Chapter 17.96.040
Temporary Uses	See 17.76.190			
Urban Agriculture				
Home Garden	P	P	-	
Community Garden	M	M	-	
Urban Farm	C	C	-	

Notes:

- [1] Combination of two or more tenant suites within a multi-tenant building or greater than 5,000 sq. ft. requires Minor Use Permit
- [2] Combination of two or more tenant suites within a multi-tenant building or greater than 5,000 sq. ft. requires Conditional Use Permit
- [3] Without stock. Storage of merchandise limited to samples only.
- [4] Prohibited within 100 feet of a residential zoning district or residential use.
- [5] Permitted only on a mixed use site with the residential use secondary to the primary commercial uses on the site. Residential uses on the site are limited to less than 50 percent of the floor area of buildings on the site. Residential uses shall be located and designed to maintain a primarily commercial character and function on the site.

**B. Additional Permits.** In addition to permits identified in Table 17.24-1, development projects in the commercial and industrial zoning districts may also require a Design Permit pursuant to Chapter 17.120 (Design Permits). Modifications to a historic resource may require a Certificate of Appropriateness pursuant to Chapter 17.84 (Historic Preservation).



**Note:** Limitations on office uses in subsection C below are new.

**C. Office Uses in the C-C and C-R Zoning Districts.** In the C-C and C-R zoning districts, permits required for office uses, including professional, medical, banks, financial institutions and governmental offices, are shown in Table 17.24-2.

**TABLE 17.24-2: PERMITTED OFFICE USES IN THE C-C AND C-R ZONING DISTRICTS**

Location and Size of Office Use	C-C Zoning District	C-R Zoning District
Conversion of a retail use to an office use	N/A	C
Ground floor, less than 5,000 sq. ft.	P	C
Ground floor, 5,000 sq. ft. or more	C	C
Upper floor above a ground floor	P	P
Located within a multi-tenant site in which the office space is not located within a storefront and is setback from the front façade.	P	P

**17.24.030 Development Standards**

**A. General.** Table 17.24-3 identifies development standards that apply in the commercial and industrial zoning districts.

**TABLE 17.24-3: DEVELOPMENT STANDARDS IN COMMERCIAL AND INDUSTRIAL ZONING DISTRICTS**

Attachment: Part 1 and Part 2 Draft Zoning Code PC Redlines (1512 : Zoning Code Update)

	C-C	C-R	I	Additional Standards
<b>Site Requirements</b>				
Parcel Area, Minimum	5,000 sq. ft.			
Parcel Width, Minimum	50 ft.			
Parcel Depth, Minimum	100 ft.			
Floor Area Ratio, Maximum	1.0	1.5	0.5	17.24.030.C <u>17.88</u>
Residential Density, Maximum	20 du/acre		N/A	
<b>Structure Requirements</b>				
Setbacks, Minimum				
Front	See 17.24.030.B		0 ft.	
Rear	0 ft. unless adjacent to a residential zoning district (see 17.24.030.D)			
Interior Side	0 ft. unless adjacent to a residential zoning district (see 17.24.030.D)			
Street Side	See 17.24.030.B		0 ft.	
Height, Maximum	40ft.	40 ft.	30 ft.	17.24.030.C & D
Landscaped Open Space, Minimum	5%		<del>4%</del> Δs determined by the permit approval process	<u>Table 17.72-1</u>
Parking and Loading	See 17.76			

**Notes:**

[1] 15 ft. min. from property line abutting a residential zoning district.

**B. Front and Street Side Setbacks in the C-R and C-C Zoning Districts.** In the C-R and C-C zoning districts, buildings shall be setback from the front and street side property line so that:

1. The building is at least 15 feet from the curb or street edge; and
2. Building placement allows for a minimum 10-foot sidewalk along the property frontage. See Figure 17.24-1.



**Note:** The existing Zoning Code requires front setbacks of 15 feet from the property line. Subsection B above requires front setbacks of 15 feet from the curb or street edge.

**FIGURE 17.24-1: FRONT AND STREET SIDE SETBACKS IN THE C-R AND C-C ZONING DISTRICTS**

Attachment: Part 1 and Part 2 Draft Zoning Code PC Redlines (1512 : Zoning Code Update)

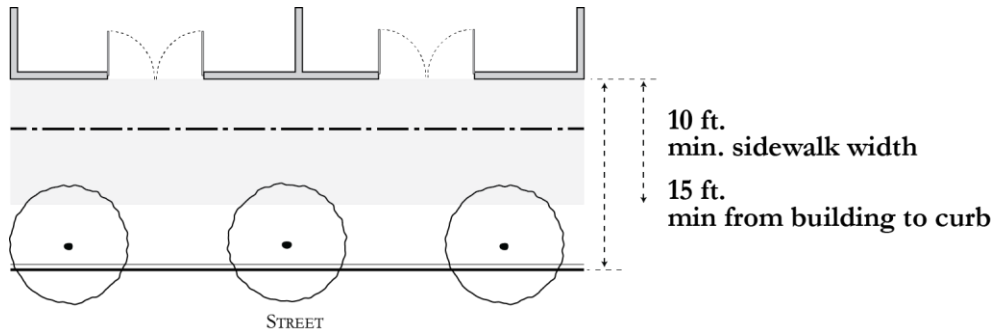

### C. Increased Floor Area and Height in C-C and C-R Zoning Districts.



**Note:** Section 17.27.080 in the existing Zoning Code allows the City Council to approve height exceptions with no specified limit. This section establishes increased floor area and height allowances consistent with General Plan policies and adds in Chapter 17.88 an upper limit for height exceptions.

1. **General.** As provided in Chapter 17.88 (Incentives for Community Benefits), the City Council may approve exceptions to height and floor area ratio (FAR) limits shown in Table 17.24-2 for proposed projects in the C-C and C-R zoning districts. These exceptions are intended to facilitate the redevelopment of underutilized properties along 41<sup>st</sup> Avenue consistent with the vision for the corridor described in the General Plan.
  - ~~0. **Increased FAR.** The City Council may allow an increased FAR up to a maximum of 2.0 for proposed development projects in the C-C and C-R zoning districts. To be eligible for an increased FAR, properties must front 41st Avenue or the 41st Avenue/Capitola Road intersection or be part of the Capitola Mall site. Structures on parcels fronting the east side of 41st Avenue that apply for the increased FAR must be set back a minimum of 100 feet from a property line abutting a residential property.~~
  - ~~0. **Increased Height.** The City Council may allow an exception to the 40-foot height limit in the C-R and C-C zoning districts up to maximum of 50 feet.~~
  - ~~0. **Community Benefit Required.** To be eligible for increased FAR or height in the C-C and C-R zoning districts, a project must provide a substantial community benefit consistent with Chapter 17.88 (Incentives for Community Benefits).~~
  - ~~0. **Planning Commission Recommendation.** At a noticed public hearing the Planning Commission shall provide a recommendation to the City Council on any request for increased FAR or height in the C-C and C-R zoning districts.~~

~~0. **Basis for Approval.** To approve increased FAR or a height exception in the C-C and C-R zoning districts, the City Council must make all findings specified in Section 17.88.080 (Findings) in Chapter 17.88 (Incentives for Community Benefits). The City Council may approve increased FAR or a height exception only for projects that provide a substantial community benefit, enhance the economic vitality of the 41<sup>st</sup> Avenue corridor, and minimize adverse impacts to neighboring properties as required by General Plan Action LU-9.3.~~

**1.D. Residential Transition Standards.** Where a commercial or industrial zoning district abuts a residential zoning district, the following standards apply.



**Note:** Daylight plane requirement in paragraph 2 below is new.

1. **Setbacks.** The minimum setback from the residential property line shall be 15 feet for interior side yards and 20 feet for rear yards.
2. **Daylight Plane.** No structure shall extend above or beyond a daylight plane having a height of ~~20~~ 25 feet at the setback from the residential property line and extending into the parcel at an angle of 45 degrees. See Figure 17.24-2.
3. **Landscaping.** A landscaped planting area, extending a minimum of 10 feet from the property line, shall be provided along all residential property lines. A tree screen shall be planted in this area with trees planted at a minimum interval of 15 feet.

**FIGURE 17.24-2: RESIDENTIAL TRANSITIONS – DAYLIGHT PLANE**

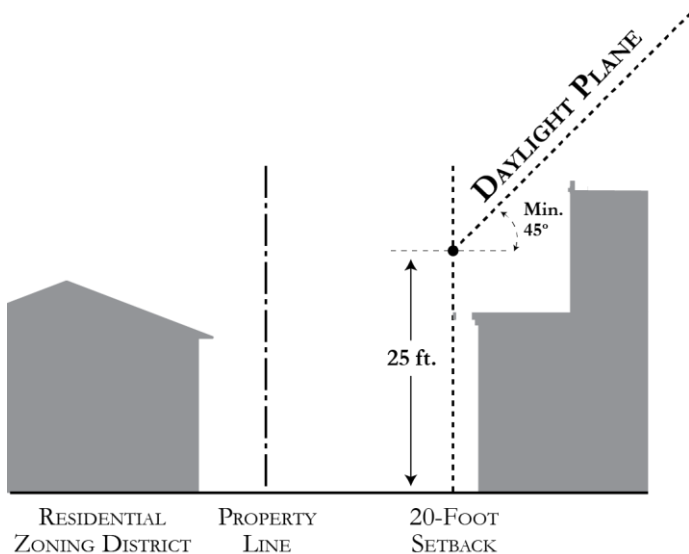

4. **Loading.** Loading and unloading shall be designed to have the least amount of impact on neighboring residential uses. When feasible, loading and unloading provided from the commercial frontage rather than from areas adjacent residential uses.



**J.E. Capitola Mall Redevelopment.** Any major redevelopment of the Capitola Mall, as determined by the Community Development Director, shall require the preparation and approval of a Specific Plan.

## Chapter 17.32 – SPECIAL PURPOSE ZONING DISTRICTS

### Sections:

- 17.32.010 Purpose of the Special Purpose Zoning Districts
- 17.32.020 Land Use Regulations
- 17.32.030 Development Standards

### 17.32.010 Purpose of the Special Purpose Zoning Districts

- A. Community Facility (CF).** The CF zoning district provides areas for public and community facilities serving Capitola residents and visitors. Land uses permitted in the CF zoning district include public uses such as governmental offices, police and fire stations, community centers, schools, libraries, and other similar uses. The CF zoning district implements the Public/Quasi-Public land use designation in the General Plan.
- B. Parks and Open Space (P/OS).** The P/OS zoning district provides parks, recreational facilities, and open space for the use and enjoyment of the community. The P/OS zoning district also protects and preserves environmentally sensitive natural areas and habitat in Capitola. The P/OS zoning district implements the Parks and Open Space land use designation in the General Plan.

### 17.32.020 Land Use Regulations

- A. Permitted Uses.** Table 17.32-1 identifies land uses permitted in the CF and P/OS zoning districts.
- B. Commercial Uses in the P/OS Zoning Districts.** Commercial uses that are accessory to a permitted use in in the P/OS zoning district are permitted with a Conditional Use Permit.
- C. Visitor Accommodations in New Brighten State Beach.** Visitor accommodations and campground uses are permitted in the New Brighten State beach ~~at a maximum intensity of three units per gross lot area.~~
- D. P/OS Standards.** The following standards apply to uses in the P/OS zoning district.
  1. Any structure, land use, or removal of vegetation or natural materials that in the opinion of the Planning Commission is inconsistent with the purpose of the P/OS zoning district is prohibited.
  2. Development shall be subordinate to its recreational, scenic, or natural resource purpose consistent with the Local Coastal Program (LCP). Natural resource protection shall include protection of arroyos, creeks and riparian corridors, woodlands and other environmentally sensitive habitat.
  3. No new permanent structures are permitted on the open, sandy beach area of Capitola except for facilities required for public health and safety (e.g., lifeguard stands, approved beach erosion control structures).

**TABLE 17.32-1: PERMITTED LAND USES IN THE CF AND P/OS ZONING DISTRICTS**

Key	Zoning District		Additional Regulations
	CF	P/OS	
<b>P</b> Permitted Use			
<b>A</b> Administrative Permit required			
<b>M</b> Minor Use Permit required			
<b>C</b> Conditional Use Permit required			
<b>-</b> Use not allowed			
<b>Public and Quasi-Public Uses</b>			
Colleges and Trade Schools	C	-	
Community Assembly	P [1]	-	
Cultural Institutions	P [1]	-	
Day Care Centers	P [1]	-	
Government Offices	P	-	
Parks and Recreational Facilities	P [1]	P [1]	
Public Safety Facilities	P	-	
Schools, Public or Private	P	-	
<b>Transportation, Communication, and Utilities Uses</b>			
Recycling Collection Facilities	C	-	17.96.130
Utilities, Major	C	C	
Utilities, Minor	P	P	
Wireless Telecommunications Facilities	See Chapter 17.104		
<b>Other Uses</b>			
Accessory Uses and Structures	See Chapter 17.52		
Temporary Uses and Structures	See Section 17.96.170		
Urban Agriculture			
Community Gardens	M [1]	M [1]	
Urban Farms	C [1]	C [1]	

Notes:

[1] Publicly owned and/or operated facilities only.

**~~E. Public Parking in the Coastal Zone.~~**

- ~~1. Public parking existing as of [date of Zoning Ordinance adoption] in the following locations in the CF zoning district shall be maintained for public parking:
 
  - ~~a. The Upper City Hall parking lot;~~
  - ~~b. The Cliff Drive overlook parking; and~~~~

Attachment: Part 1 and Part 2 Draft Zoning Code PC Redlines (1512 : Zoning Code Update)

~~e. The Cliff Drive Southern Pacific railroad right of way parking unless Cliff Drive must be relocated due to cliff erosion.~~

~~2. Substantial changes in public parking facilities in the coastal zone require a Local Coastal Program (LCP) amendment.~~

*Note: Public Parking in the Coastal Zone subsection E has been moved to Chapter 17.76 (Parking and Loading).*

### 17.32.030 Development Standards

- A. Floor Area Ratio.** The maximum permitted floor area ratio (FAR) is 0.25 in the P/OS zoning district and as determined by the Planning Commission through the Design Review process in the P/OS zoning district.
- B. Other Development Standards.** Other development standards (e.g., setbacks, height, building coverage) in the CF and P/OS zoning districts shall be determined by the Planning Commission through the Design Review process.

## Chapter 17.36 – PLANNED DEVELOPMENT ZONING DISTRICT

### Sections:

[17.36.010 Purpose of the Planned Development Zoning District](#)

[17.36.020 Where Allowed](#)

[17.36.030 Permitted Land Uses](#)

[17.36.040 Development Standards](#)

[17.36.050 Required Approvals](#)

[17.36.060 Conceptual Review](#)

[17.36.070 Planned Development Rezoning](#)

[17.36.080 Development Plans](#)

~~17.36.010 Purpose of the Planned Development Zoning District~~

~~17.36.020 Where Allowed~~

~~17.36.030 Permitted Land Uses~~

~~17.36.040 Development Standards~~

~~17.36.050 Required Approvals~~

~~17.36.060 Preliminary Development Plans~~

~~17.36.070 Planned Development Rezoning~~

~~17.36.080 Final Development Plans~~

### 17.36.010 Purpose of the Planned Development Zoning District

The purpose of the Planned Development (PD) zoning district is to allow for high quality development that deviates from standards and regulations applicable to the other zoning districts in Capitola. The PD zoning district is intended to promote creativity in building design, flexibility in permitted land uses, and innovation in development concepts. The PD zoning district provides land owners with enhanced flexibility to take advantage of unique site characteristics and develop projects that will provide public benefits for residents, employees, and visitors. Development within each PD zoning district is regulated by a ~~Preliminary and Final~~ Development Plan approved by the City Council.

### 17.36.020 Where Allowed



**Note:** This section prohibits PD zoning on properties designated for single-family residential use. Section 17.39.020 in the existing Zoning Code allows PD zoning for all uses. The existing minimum parcel size for PD zoning also has been removed.

The PD zoning district may be applied to any property in Capitola with an area of 20,000 square feet or more except for those designated as Single-Family Residential on the Zoning Map and General Plan Land Use Map.

**17.36.030 Permitted Land Uses**

Permitted land uses in each PD zoning district shall conform to the applicable General Plan land use designation and to the ~~Final~~ Development Plan that applies to the property.

**17.36.040 Development Standards**

- A. Established in ~~Final~~ Development Plan.** Development standards (e.g., height, setbacks, building coverage) for each PD zoning district shall be established in the applicable ~~Final~~ Development Plan.
- B. Maximum Intensity.** The maximum permitted floor area ratio and residential density shall not exceed maximums established in the General Plan for the applicable land use designation.
- C. Public Improvements.** Public infrastructure and improvements in the PD zoning district shall conform to the ~~C~~city’s standard specifications as maintained by the ~~City Engineer~~Public Works Director.

**17.36.050 Required Approvals**

- A. Development Plans and Zoning Map Amendments.** Establishment of a PD zoning district requires approval of a ~~Preliminary~~ Development Plan ~~followed by concurrent approval of a and Zoning Map amendment and a Final Development Plan.~~
- B. Design Review.** A proposed development must receive a Design Permit as required by Chapter 17.120 (Design Permits). All development and land uses within a PD zoning district shall be consistent with the approved ~~Final~~ Development Plan.

**17.36.060 ~~Preliminary Development Plans~~ Conceptual Review**



**Note:** This section ~~requires City Council approval of a~~replaces the existing Preliminary Development Plan approval process with the requirement to for Conceptual Review, which is an advisory (non-binding) process for the Planning Commission and City Council to provide feedback on the project prior to the submittal of a formal application. The existing Zoning Code requires only Planning Commission approval of a Preliminary Development Plan.

~~Prior to submittal of an application for a PD rezoning and Development Plan, an applicant must complete the Conceptual Review process as described in Section Chapter 17.11412.030 (Conceptual Review). The Planning Commission and City Council shall each hold at least one noticed public hearing on the project as part of the Conceptual Review process.~~

- ~~**A. Review Authority.** The City Council takes action on Preliminary Development Plan applications following recommendation from the Planning Commission.~~
- ~~**B. Application Submittal and Review.**~~
  - ~~1. Preliminary Development Plan applications shall be filed and reviewed in compliance with Chapter 17.112 (Permit Application and Review). The application shall include the~~

~~information and materials required by the Community Development Department and the information required by Paragraph C (Application Materials) below.~~

~~2.1. If the property is not under a single ownership, all owners must join the application, and a map showing the extent of ownership shall be submitted with the application.~~

~~3.1. It is the responsibility of the applicant to provide evidence in support of the findings required by Paragraph F (Findings) below.~~

~~**C. Application Materials.** Preliminary Development Plan applications shall include the following information and materials:~~

~~1. **Project Description.** A written description of the project proposed within the PD zoning district. The project description shall include a narrative statement of the project objectives and a statement of how the proposed project will comply with General Plan goals and policies for the applicable land use designation. An overview of the proposed land use, densities, open space, and parking should be included in the project description.~~

~~2.1. **Community Benefits.** A description of how the proposed development is superior to development that could occur under the standards applicable in other zoning districts, and how it will achieve superior community design, environmental preservation, and/or substantial public benefits as defined in Paragraph G below.~~

~~3.1. **Site Map.** Maps depicting the existing topography, on-site structures and natural features, mature trees, and other significant vegetation and drainage patterns. The map shall show the proposed PD zoning district boundaries and all properties within 500 feet of the site boundary.~~

~~4.1. **Concept Plan.** An overall diagram of the project concept. This diagram shall illustrate the overall development concept, including proposed land uses, buildings, circulation, open space, and any other significant elements in the proposed project. Phases shall be clearly indicated if multiple phases are proposed.~~

~~5. **Infrastructure.** A written description of the infrastructure necessary to serve each phase of the project proposed.~~

~~**D. Planning Commission Review and Recommendation.**~~

~~1. The Planning Commission shall hold a public hearing on the Preliminary Development Plan application as required by Chapter 17.148 (Public Notice and Hearings).~~

~~2. The Planning Commission shall recommend to the City Council the approval, approval with modification, or denial of the Preliminary Development Plan application. The recommendation shall be based on the findings in Paragraph F (Findings) below.~~

~~**E. City Council Review and Decision.** Upon receipt of the Planning Commission's recommendation, the City Council shall conduct a public hearing and either approve, approve with modification, or deny the Preliminary Development Plan.~~

~~**F. Findings.** The City Council may approve an application for a Preliminary Development Plan only if all of the following findings can be made:~~

- ~~1. The proposed development is consistent with the General Plan, Local Coastal Program (if applicable), and any applicable specific plan or area plan adopted by the City Council.~~
- ~~2. The proposed development is superior to the development that could occur under the standards applicable in the other zoning districts.~~
- ~~3. The proposed project will provide a substantial public benefits as defined in Paragraph G (Substantial Public Benefit Defined) below.~~
- ~~4. The site for the proposed development is adequate in size and shape to accommodate proposed land uses.~~
- ~~5. Adequate transportation facilities, infrastructure, and public services exist or will be provided to serve the proposed development.~~
- ~~6. The proposed development will not have a substantial adverse effect on surrounding property and will be compatible with the existing and planned land use character of the surrounding area.~~

 **Note:** The requirement that a PD project provide a substantial public benefit in Finding 3 above and described in subsection G below is new.

~~**G. Substantial Public Benefit Defined.** When used in this chapter, “substantial public benefit” means a project feature not otherwise required by the Zoning Code or any other provision of local, State, or federal law that significantly advances goals of the General Plan. Examples of substantial public benefits include but are not limited to:~~

- ~~1. Affordable housing that meets the income restrictions applicable in the Affordable Housing (AH) overlay zone.~~
- ~~2. Public plazas, courtyards, and other public gathering places that provide opportunities for people to informally meet and gather.~~
- ~~3. Improved walkways and paths for bicycles and pedestrians within properties, enhanced connections for bicyclists and pedestrians between properties.~~
- ~~4. Green building and sustainable development features that substantially exceed the City’s minimum requirements.~~
- ~~5. Preservation, restoration, or rehabilitation of a historic resource.~~
- ~~6. Increased ability to for residents and visitors to walk, bike, and take transit to destinations and reduce greenhouse gas emissions.~~
- ~~7. Publicly available parking to serve the Village.~~
- ~~8. Publicly accessible parks and open space beyond the minimum required by the City or other public agency.~~
- ~~9. Habitat restoration and or protection of natural resources beyond the minimum required by the City or other public agency.~~

~~**H. Conditions of Approval.** The City Council may attach conditions of approval to a Preliminary~~



~~Development Plan to achieve consistency with the General Plan, Local Coastal Program, Zoning Code, and any applicable specific plan or area plan adopted by the City Council.~~

~~I. **Extent of Approval.** Approval of the Preliminary Development Plan shall be limited to general acceptability of the land uses proposed and their interrelationship, and shall not be construed to endorse or dictate the precise location of uses, configuration of parcels, or engineering feasibility.~~

~~J. **Expiration of Approval.**~~

~~1. A Preliminary Development Plan shall expire and become void unless a Final Development Plan application is submitted within one year of Preliminary Development Plan approval.~~

~~2. The Community Development Director may approve a one year extension to the Preliminary Development Plan if the Director determines that the applicant has proceeded in good faith and has exercised due diligence in efforts to submit the Final Development Plan in a timely manner.~~

~~3. The applicant shall submit to the Community Development Department a written request for an extension of time no later than ten days before the expiration of the Preliminary Development Plan.~~

#### 17.36.070 Planned Development Rezoning

- A. General Procedures and Requirements.** Establishing a PD zoning district requires City Council approval of a Zoning Map amendment consistent with Chapter 17.144 (Zoning Code Amendments). All procedures and requirements for Zoning Map Amendments in Chapter 17.144 apply to the establishment of a PD zoning district.
- B. Timing.** The City Council shall act on the Zoning Map Amendment concurrently with the **Final** Development Plan. A PD zoning district may be established only with concurrent approval of a **Final** Development Plan.
- C. Reference to ~~Final~~ Development Plan.** The ordinance adopted by the City Council establishing a PD zoning district shall reference the **Final** Development Plan approved concurrently with the Zoning Map Amendment.

#### 17.36.080 ~~Final~~ Development Plans

- A. Review Authority.** The City Council takes action on ~~Final~~ Development Plan applications following recommendation from the Planning Commission.
- B. Timing.** ~~A Final Development Plan application may be submitted only after City Council approval of a Preliminary Development Plan.~~ A Development Plan application shall be submitted within one year of Conceptual Review for the proposed project. If an application is not submitted within one year of Conceptual Review, the applicant shall complete a second Conceptual Review process prior to submitting the Development Plan application.
- C. Application Submittal and Review.**

1. ~~Final~~ Development Plan applications shall be filed and reviewed in compliance with Chapter 17.112 (Permit Application and Review). The application shall include the information and materials required by the Community Development Department and the information required by Paragraph D (Application Materials) below.

2. If the property is not under a single ownership, all owners must join the application, and a map showing the extent of ownership shall be submitted with the application.

It is the responsibility of the applicant to provide evidence in support of the findings required by Paragraph ~~G~~F (Findings) below.

**C.D. Application Materials.** Applications for approval of a ~~Final~~ Development Plan shall include the following information and materials:

1. Project Description. A written description of the project proposed within the PD zoning district. The project description shall include a narrative statement of the project objectives and a statement of how the proposed project will comply with General Plan goals and policies for the applicable land use designation. An overview of the proposed land use, densities, open space, and parking should be included in the project description.

2. Community Benefits. A description of how the proposed development is superior to development that could occur under the standards applicable in ~~other~~ the existing zoning districts, and how it will achieve superior community design, environmental preservation, and/or a substantial public benefits as defined in Paragraph ~~H~~G below.

3. Site Map. Maps depicting the existing topography, on-site structures and natural features, mature trees, and other significant vegetation and drainage patterns. The map shall show the proposed PD zoning district boundaries and all properties within 500 feet of the site boundary.

4. Concept Plan. An overall diagram of the project concept. This diagram shall illustrate the overall development concept, including proposed land uses, buildings, circulation, open space, and any other significant elements in the proposed project. Phases shall be clearly indicated if multiple phases are proposed.

4.5. Land Use. A map showing the location of each land use proposed within the site, including open space and common areas. The land use map shall be accompanied by a narrative description of permitted land uses, allowable accessory uses, and uses allowed by-right or with a Conditional Use Permit.

2.6. Subdivision Map. If the project involves the subdivision of land, a tentative parcel map or tentative map required by Title 16 (Subdivisions) of the Capitola Municipal Code.

3.7. Circulation. A map and descriptions of the major circulation features within the site including vehicular, bicycle, pedestrian facilities; traffic flow of internal traffic; and existing and proposed public streets and sidewalk improvements.

**4.8. Public Facilities and Open Space.** The amount (in square feet or acres) and percentage of site area that will be dedicated for all types of open space, including proposed recreational facilities and amenities; and any public facilities, including public utility easements, public buildings and public land uses.

**5.9. Development Standards.** All development standards that apply within the project, including:

- a. Land use;
- b. Circulation of traffic;
- c. Landscaping;
- d. Architecture;
- e. Density and/or intensity;
- f. Minimum building site;
- g. Minimum lot dimensions;
- h. Maximum building coverage;
- i. Minimum setbacks;
- j. Maximum building or structure heights;
- k. Maximum height of fences and walls;
- l. Signs;
- m. Off-street parking; and
- n. Other items as deemed appropriate by the Planning Commission and City Council.

**D.E. Planning Commission Review and Recommendation.**

1. The Planning Commission shall hold a public hearing on the ~~Final~~ Development Plan application as required by Chapter 17.148 (Public Notice and Hearings).
2. The Planning Commission shall recommend to the City Council the approval, approval with modification, or denial of the ~~Final~~ Development Plan application. The recommendation shall be based on the findings in Paragraph G (Findings) below.

**E.F. City Council Review and Decision.** Upon receipt of the Planning Commission's recommendation, the City Council shall conduct a public hearing and either approve, approve in modified form, or deny the ~~Final~~ Development Plan. The City Council may approve the application only if all of the findings in Paragraph G (Findings) below can be made.

**F.G. Findings.** The City Council may approve an application for a ~~Final~~ Development Plan if all of the following findings can be made:

- ~~1. The Final Development Plan is consistent with the spirit and intent of the Preliminary~~

~~Development Plan.~~

- ~~2. Findings made to approve the Preliminary Development Plan remain valid for the Final Development Plan, including that the project will provide a substantial community benefit as defined in Section 17.36.060.G (Substantial Public Benefit Defined).~~
- ~~3. Findings required for the concurrent approval of a Zoning Map Amendment can be made:~~
  - ~~1. The proposed development is consistent with the General Plan, Local Coastal Program (if applicable), and any applicable specific plan or area plan adopted by the City Council.~~
  - ~~2. The proposed development is superior to the development that could occur under the standards applicable in the other existing zoning districts.~~
  - ~~3. The proposed project will provide a substantial public benefits as defined in Paragraph H (Substantial Public Benefit Defined) below. The public benefit provided shall be of sufficient value as determined by the Planning Commission to justify deviation from the standards of the zoning district that currently applies to the property.~~
  - ~~4. The site for the proposed development is adequate in size and shape to accommodate proposed land uses.~~
  - ~~5. Adequate transportation facilities, infrastructure, and public services exist or will be provided to serve the proposed development.~~
  - ~~6. The proposed development will not have a substantial adverse effect on surrounding property and will be compatible with the existing and planned land use character of the surrounding area.~~
  - ~~7. Findings required for the concurrent approval of a Zoning Map Amendment can be made.~~



**Note:** The requirement that a PD project provide a substantial public benefit in Finding 3 above and described in subsection H below is new.

**H. Substantial Public Benefit Defined.** When used in this chapter, “substantial public benefit” means a project feature not otherwise required by the Zoning Code or any other provision of local, state, or federal law that substantially exceeds the city’s minimum development standards and significantly advances goals of the General Plan. A project must include one or more substantial public benefits to be rezoned as a planned development. The public benefit provided shall be of sufficient value as determined by ~~Planning Commission~~ City Council to justify deviation from the standards of the zoning district that currently apply to the property. Examples of substantial public benefits include but are not limited to:

- ~~1. Affordable housing that meets the income restrictions applicable in the Affordable Housing (-AH) overlay zone.~~

~~Public plazas, courtyards, open space, and other public gathering places that provide opportunities for people to informally meet and gather. The public space must either exceed the City's minimum requirement for required open space and/or include quality~~

improvements to the public realm to create an exceptional experience for the public.

2. Improvements to streets, sidewalks, curbs, gutters, sanitary and storm sewers, street trees, lighting, and other public infrastructure beyond the minimum required by the city or other public agencies.
3. New or improved pedestrian and bicycle pathways that enhance circulation within the property and connectivity to the surrounding neighborhood.
4. Green building and sustainable development features that substantially exceed the City's minimum requirements.
5. Preservation, restoration, or rehabilitation of a historic resource.
6. Public art that exceeds the City's minimum public art requirement and is placed in a prominent and publicly accessible location.
7. New or enlarged business that increase the supply of jobs available to Capitola residents of all income levels.
8. Increased transportation options for residents and visitors to walk, bike, and take public transit to destinations and reduce greenhouse gas emissions.
9. Public parking lot that provides parking spaces in excess of the required number of parking spaces for use by the surrounding commercial district.
10. Publicly accessible parks and open space beyond the minimum required by the City or other public agency.
11. Habitat restoration and or protection of natural resources beyond the minimum required by the City or other public agency.

**G.I. Conditions of Approval.**

1. The City Council may attach conditions of approval to a ~~Final~~ Development Plan to achieve consistency with the General Plan, Local Coastal Program, Zoning Code, and any applicable specific plan or area plan adopted by the City Council.
2. The City Council shall condition approval of the ~~Final~~ Development Plan on the completion of public improvements and grants of easement shown on the ~~Final~~ Development Plan.

**H.J. Post-Decision Procedures.** Post-decision procedures and requirements in Chapter 17.156 (Post-Decision Procedures) shall apply to ~~Final~~ Development Plans.

**Note:** Effect of Development Plan in subsection ~~KJ~~ below is new.

**I.K. Effect of Development Plan.** All future development and land uses within a PD zoning district shall comply with the approved ~~Final~~ Development Plan.

1. **Land Uses.** New land uses may be added in a PD zoning district provided the ~~Final~~ Development Plan identifies the use as a permitted or conditionally permitted land use. Establishing a land use not specifically permitted by the ~~Final~~ Development Plan would require an amendment to the PD zoning district.



2. **Structures.** New structures may be added in a PD zoning district provided the structures comply with development standards established in the ~~Final~~ Development Plan (e.g., height, setback, floor area ratio). Design Review consistent with Chapter 17.120 (Design Permits) is required for all new development that was not approved with the ~~Final~~ Development Plan. Development that exceeds development standards in the ~~Final~~ Development Plan is allowed only with an amendment to the PD zoning district.

## Chapter 17.40 – RESIDENTIAL OVERLAY ZONES

### Sections:

- 17.40.010 Purpose
- 17.40.020 Affordable Housing (-AH) Overlay Zone
- 17.40.030 Vacation Rental Use (-VRU) Overlay Zone
- 17.40.040 Village Residential (-VR) Overlay Zone

### 17.40.010 Purpose

This chapter contains requirements for overlay zones that primarily apply to residential uses and residential areas. Overlay zones establish additional standards and regulations to specific areas, in addition to the requirements of the underlying base zoning district.

### 17.40.020 Affordable Housing (-AH) Overlay Zone

**A. Purpose.** The purpose of the Affordable Housing (-AH) overlay zone is to facilitate the provision of affordable housing units through the retention and rehabilitation of existing affordable units, or the construction of new affordable units. The -AH overlay zone is intended to:

1. Implement the goals and policies of the General Plan Housing Element and provide the opportunity and means for Capitola to meet its regional fair share allotment of affordable units.
2. Encourage the development of affordable units by assisting both the public and private sector in making the provision of these units economically viable.
3. Provide assurances to the City that these units will maintain a high degree of quality and will remain affordable to the target population over a reasonable duration of time.
4. Encourage the provision of affordable housing through the combination of the -AH overlay with the multi-family residential zone where the affordable housing projects are determined to be feasible and are consistent with the General Plan.
5. Provide a means of directing and simplifying the process for creating and maintaining affordable housing.
6. Provide incentives to developers, whether in new or rehabilitated housing, to maintain rental units for the long term (e.g., not less than 55 years) and affordable ownership units in perpetuity.

**B. Applicability.** The -AH overlay zone may be applied to parcels that are one acre or more in size and located in a multi-family residential zoning district.

**C. Definitions.**

1. “Affordable housing” means housing capable of being purchased or rented by a household with “very low,” “low,” or “moderate” income levels at an “affordable housing cost” or “affordable rent,” as those terms are defined by the State of California.
2. “Affordable housing overlay district” means a zoning district that applies in addition to existing zoning designation where the city encourages the provision of affordable housing units as described in this chapter.
3. The “very low,” “low,” and “moderate” income levels are defined by the State of California in Sections 50105, 50079.5, and 50093, respectively, of the California Health and Safety Code, and in Subchapter 2 of Chapter 6.5 of Division 1 of Title 25 of the California Code of Regulations, commencing with Section 6900. These income levels are:
  - a. Very Low Income. Up to and including fifty percent of the Santa Cruz County median income, adjusted for family size, as defined by the state law;
  - b. Lower Income. Fifty-one percent to eighty percent of Santa Cruz County median income, adjusted for family size, as defined by the state law;
  - c. Moderate Income. Eighty-one percent to one hundred twenty percent of Santa Cruz County median income, adjusted for family size, as defined by state law.
4. “Affordable housing cost” and “affordable rent” are defined in Sections 50052.5 and 50053, respectively, of the California Health and Safety Code, and in Subchapter 2 of Chapter 6.5 of Division 1 of Title 25 of the California Code of Regulations, commencing with Section 6900.

**D. Relationship with State Density Bonus Law and Other State Laws.**

1. All of the state laws and regulations referenced above, or their successors in defined terms when amended, shall be incorporated herein as though fully set forth. In the event of any inconsistency or discrepancy between the income and affordability levels set forth in this chapter and the levels set in state laws and regulations, the State provisions shall control.
2. The -AH overlay zone provides a density increase for affordable housing development that in most cases exceeds density bonuses permitted by state law (Government Code Section 65915).
3. A development may utilize the -AH overlay zone as an alternative to the use of state density bonus but may not utilize both the overlay and state density bonuses.

**E. Permits and Approvals Required.**

1. Affordable housing developments proposed under this chapter require the execution of a Development Agreement by the City and the developer. The Development Agreement shall be prepared in accordance with the provisions of California Government Code Section 65864 et seq.



2. Affordable housing developments proposed under this chapter require approval of a Design Permit. All requirements in Chapter 17.120 (Design Permits) apply, except that the Planning Commission recommends Design Permit approval or denial to the City Council. The City Council may take action on the Design Permit application concurrently with or subsequent to action on the Development Agreement.

**F. Permitted Residential Density.**

1. Affordable housing developments with up to 20 units per acre are permitted in the -AH overlay zone. The 20 units per acre limit is based on a calculation that includes all existing and new units on the property.
2. Density permitted by in the -AH overlay zone may not exceed what can be accommodated by the site while meeting applicable parking, unit size, and other development standards.

**G. Income Restrictions.**

1. A minimum of 50 percent of the units in an affordable housing development shall be income restricted affordable housing. All affordable units may be in a single category or part of a mixture of affordable unit types which include:
  - a. Moderate-income households;
  - b. Lower-income households;
  - c. Very low-income households; or
  - d. Extremely low-income households.
2. At minimum 50 percent of income-restricted affordable units (25 percent of the total project units) shall be affordable to low-, very low-, and extremely-low income households. A greater level of affordability will not allow a greater level of density.

**H. Development Incentives.**

1. **Purpose.**
  - a. In order to reduce costs associated with the development and construction of affordable housing, affordable housing developments within the -AH overlay zone shall be eligible for specified development incentives. These incentives allow for the relaxation of development standards normally applied to housing in Capitola and are established in order to facilitate and promote the development of affordable housing in the City.
  - b. Incentives shall be targeted to improve the project design or to yield the greatest number of affordable units and required level of affordability, so as to permit the City to meet its regional fair share allotment of affordable housing and the goals of the Housing Element of the General Plan.

2. **Relaxed Development Standards.** The City shall allow the following relaxed development standards for projects that comply with the affordability required specified in Subsection G (Income Restrictions):
- a. **Minimum Building Site Area and Lot Area per Unit.** There shall be no minimum building site area requirement for individual parcels or dwelling sites within the -AH overlay zone. The building site area shall be designated on a site plan as approved by the City through the Design Permit review process.
  - b. **Density Averaging.** Project density within the -AH overlay zone may be calculated by averaging the density on a project-wide basis so as to permit higher density levels in certain project portions in exchange for advantageous project design features as determined by the City through the Design Permit review process.
  - c. **Setbacks.**
    - (1) The minimum setbacks from property lines shall be determined by the City through the Design Permit process.
    - (2) Minimum setbacks from property lines adjacent to or across from a single-family residential zone shall be same as underlying zoning district.



**Note:** Section 17.20.050.C.6 in the existing Zoning Code requires 20-foot first floor and 50-foot second floor minimum setbacks from property lines adjacent to or across from a single-family residential zoning district. Subparagraph c above removes this requirement as it is not a relaxed development standard and would render development infeasible in many locations.

- d. **Lot Coverage.** The City shall determine the maximum lot coverage for the proposed project through the Design Permit process.
  - e. **Parking.** Projects shall provide a minimum of:
    - (1) Two off-street parking spaces per unit; and
    - (2) One off-street visitor parking space for every seven units.
3. **Additional Development Incentives.**
- a. As a further inducement to the development of affordable housing beyond the relaxed development standards described in Section 2 (Relaxed Development Standards) above, the City may choose to extend one or more additional development incentives depending on the quality, size, nature, and scope of the project being proposed.
  - b. Additional development incentives may be in the form of waivers or modifications of other standards which would otherwise inhibit density and achievement of affordable housing goals for the development site, including, but not limited to, the placement of public works improvements.

## I. Design Standards.

### 1. Purpose and Applicability.

- a. The following design standards are intended to ensure high-quality development within the -AH overlay zone that enhances the visual qualities of Capitola and respects adjacent homes and neighborhoods.
- b. Design standards shall apply to all projects receiving development incentives described in Section H (Development Incentives) or residential densities greater than allowed by the applicable base zone.

## 2. Neighborhood Compatibility.

- a. Affordable housing developments shall be designed and developed in a manner compatible with and complementary to existing and potential development in the immediate vicinity of the project site.
- b. Site planning on the perimeter shall provide for protection of the property from adverse surrounding influences and shall protect surrounding areas from potentially adverse influences from the property.
- c. To the greatest extent possible, the design of the development shall promote privacy for residents and neighbors, security, and use of passive solar heating and cooling through proper placement of walls, windows, and landscaping.
- d. Building design and materials shall blend with the neighborhood or existing structures on the site.

## ~~3. Pedestrian Orientation.~~

- ~~a. The front façade and main entrance of dwellings adjacent to the front property line shall face the street and must be clearly articulated through the use of architectural detailing.~~
- ~~b. The front entrance of the dwelling facing the street should be defined by at least one of the following: a porch of at least 8 feet in width and depth; roof overhang; or similar architectural element.~~
- ~~c. Except for a basement-level garage below grade, any garage, carport or other accessory structure, attached or detached, shall be located at least 15 feet behind the front of the principal building facing the front property line.~~
- ~~d. Sidewalks shall be installed along all street frontages.~~
- ~~e. Existing vegetation on the perimeter shall be preserved to maintain a buffer to existing surrounding structures. Existing significant trees are to remain whenever feasible.~~
- ~~f. The pedestrian orientation standards in subsections (a) through (e) above can be waived by the City through the Design Permit process when the review authority finds it is infeasible to comply due to physical or other constraints on the property.~~

## 4.3. Building Height. Maximum building height shall be the same as in the underlying base zoning district.



**Note:** Section 17.20.050.C.5 in the existing Zoning limits height to two stories or 27 feet, which is less than the maximum permitted height in the RM zoning district. Paragraph 4 above allows a maximum height equal to the underlying zoning district to remove an additional barrier to the construction of affordable housing.

#### 5.4. **Common Open Space.**

- a. Common open space shall comprise the greater of:
  - (1) 10 percent of the total area of the site; or
  - (2) 75 square feet for each dwelling unit.
- b. Areas occupied by buildings, streets, driveways, parking spaces, utility units, and trash enclosures may not be counted in satisfying the open space requirement.
- c. The following areas may be counted in satisfying the open space requirement:
  - (1) Landscaping and areas for passive and active recreation/open space with a minimum depth and width of 5 feet.
  - (2) Land occupied by recreational buildings and structures.

#### 6.5. **Streets.**

- a. All public streets within or abutting the proposed development shall be improved to City specifications for the particular classification of street.
- b. All private streets shall meet fire code and access standards.

7.6. **Accessory Uses and Structures.** Accessory uses and structures shall be permitted as allowed by Chapter 17.52 (Accessory Structures and Uses) and as required through the Design Permit process.

8.7. **Signs.** Signs shall be permitted as allowed by Chapter 17.80 (Signs) and as required through the Design Review process.

#### **J. Assurance of Affordability.**

1. Affordable housing units developed under this section shall remain available to persons and families of very low, low, and moderate income, at an affordable housing cost or affordable rental cost, at those income and affordability levels as defined in Section 17.40.020.C (Definitions), for a period of 55 years, unless a longer period is required by a construction or mortgage financing program, mortgage insurance program, state law, or housing grant, loan or subsidy program.
2. The required period of affordability shall run concurrently with any period of affordability required by any other agency; provided, however, that the affordability period shall not be less than 55 years, as set forth in this section.
3. The project developer shall be required to enter into an appropriate agreement with the City to ensure affordability is maintained for the required period.

#### **K. Pre-Application Consultation.**

1. Prior to submitting an application for an affordable housing development within the -AH overlay zone, the applicant or prospective developer should request preliminary consultation meetings with the Community Development Department and other City staff as appropriate, to obtain information and guidance before incurring substantial expense in the preparation of plans, surveys and other data.
2. Preliminary consultations with City staff should address potential local, state, and federal affordable housing funding availability, and program requirements in guaranteeing project consistency with the objectives and requirements of the -AH overlay zone.

**L. Additional Application Requirements.** An application for an affordable housing development within the -AH overlay zone shall be filed and reviewed in compliance with Chapter 17.112 (Permit Application and Review) and shall also include the following materials and information:

1. Breakdown of affordable and market rate units including unit number, unit size, affordable designation of each unit (very low, low, or moderate), and rental rate or sale price.
2. The proposed means for assuring the continuing existence, maintenance and operation of the project as an affordable housing project.
3. Such other information as may be required by the Community Development Department to allow for a complete analysis and appraisal of the proposed project.

**M. Findings.** To approve or recommend approval of an affordable housing development, the review authority shall make all of the following findings, in addition to the findings required by Chapter 17.120 (Design Permits):

1. The incentives granted for density and deviation from development and design standards, are commensurate with the level of affordability. Specifically, the greater the extent of concessions and incentives, the greater the level of affordability, quality, size, nature, and scope of the project being proposed.
2. The design of the proposed project, even with the concessions for density and deviation from development and design standards, is appropriate for the scale and style of the site and surrounding neighborhood. Specifically, the development will provide an attractive visual transition and will not significantly impact the integrity of the surrounding neighborhoods.
3. The developer has agreed to enter into an agreement to maintain the affordability of the project specific to the requirements of the City and any funding sources with greater or longer affordability requirements.
4. If located within the coastal zone, the project is found to be in conformity with the Local Coastal Program, including, but not limited to, sensitive habitat, public viewshed, public recreational access and open space protections.

### 17.40.030 Vacation Rental Use (-VRU) Overlay Zone

- A. Purpose.** The -VRU overlay zone identifies locations within residential areas where the short term rental of dwelling units is permitted.
- B. Applicability.** Locations where the -VRU overlay zone applies is shown on the Zoning Map.
- C. Land Use Regulations.** Permitted uses in the -VRU overlay zone are the same as in the base zoning district, expect that vacation rental uses are permitted with a Minor Use Permit.
- D. Required Permit.** Each vacation rental unit is required to obtain a Minor Permit in addition to registering each unit with the City as a business. Vacation rental registration includes obtaining a business license and transient occupancy tax registration.
- E. Development and Operations Standards.**

1. Vacation rentals in Capitola are prohibited outside of the -VRU overlay zone.
2. Transient occupation registration is required for each vacation rental unit. A business license and transient occupancy tax registration must be obtained from the City. The business license shall be renewed annually.
3. Permit holders must submit to the City transient occupancy tax report and payment monthly.
4. One parking space is required per vacation rental unit. Parking may be on site or within Pacific Cove parking lot with proof of permit. The on-site parking space must be maintained for exclusive use by guests during their stay.
5. The property owner must designate a person who has the authority to control the property and represent the owner. This responsible person must be available at all reasonable times to receive and act on complaints about the activities of the tenants.
6. A maximum of one sign per structure, not to exceed one square foot in size, is permitted to advertise the vacation rental.
7. Each unit must post the transient occupancy permit in a visible location within the unit. The transient occupancy permit will include a permit number, conditions of approval, and an area in which to write the contact information for the responsible party.
8. If the unit is advertised on the internet, the first line of the posting must include the official permit number for City reference.
9. No permit holder shall have a vested right to a renewed permit. If there is a history of the permit holder or tenants violating the permit's conditions, the permit may be revoked consistent with Section 17.60.120 (Permit Revocation). After a permit is revoked, the permit holder may reapply for a new permit one year after the

revocation. The Community Development Director may deny an application based on previous code enforcement issues. A decision by the Community Development Director is appealable to the Planning Commission.

- ~~1. Upon receiving a business license, the vacation rental unit will be inspected by the building official or designee. The Minor Use Permit may not be approved until the unit is determined to be safe. The Building Official or designee shall establish the maximum number of guests that may occupy the unit.~~
- ~~2. The vacation rental unit must provide minimum required on-site parking, or provide required parking through a Pacific Cove parking permit. The Minor Use Permit holder must designate a person who has authority to control the property and represent the landlord. This responsible person must be available at all reasonable times to receive and act on complaints about the activities of the tenants.~~
- ~~3. Only one on-site sign per unit, not to exceed 1 square foot in size, is permitted to advertise the vacation rental. Each unit must post the Minor Use Permit approval in a visible location within the unit. The Minor Use Permit approval will include a permit number, maximum occupancy, conditions of approval, and an area in which to write in the contact information for the responsible party.~~
- ~~4. If the unit is advertised on the internet, the first line of the posting must include the vacation rental permit number for City reference.~~
- ~~5. If there is a history of the permit holder or tenants violating the permit's conditions, the Minor Use Permit may be revoked consistent with Section 17.156.110 (Permit Revocation). After a Minor Permit is revoked, the permit holder may reapply for a new permit one year after the revocation, or for a greater time period as established by the Community Development Director.~~
- ~~6. Permit holders must renew the business license and transient tax registration annually.~~

#### 17.40.040 Village Residential (-VR) Overlay Zone

- A. Purpose.** The purpose of the -VR overlay zone is to limit certain areas within the Village to exclusive residential use, including vacation rentals.
- B. Land Use Regulations.**
- 1. Residential Uses Only.** Within the -VR overlay zone, only residential land uses (including vacation rentals) are permitted. Non-residential land uses, including but not limited to restaurants, retail, offices, and personal services, are not permitted in the -VR overlay zone.
  - 2. Existing Hotels and Motels.** ~~Existing hotels and motels in the -VR overlay zone shall be legal nonconforming uses and may not be expanded or intensified.~~

Alterations and modifications to existing hotels and motels shall occur in a manner consistent with Chapter 17.92 (Nonconforming Lots, Uses and Structures).

**C. Development Standards.** Development standards in the -VR overlay zone are the same as the Village Mixed Use (MU-V) zoning district.



	LOCATION IN DRAFT CHANGE	REQUESTED MODIFICATION OR DISCUSSION	IMPLEMENTATION
1 Edit	Throughout Document (Newman)	Consistency in Capitalization: Coastal, Local, State, Federal	
2 Edit	Chapter 17.04.020.B.10 - Page 04-1. Purpose and Effect of Zoning Code; (Westman)	Support a balanced transportation system that accommodates the needs of automobiles, pedestrians, bicycles and bicycles other forms of transportation"	
3 Edit	Chapter 17.08.020 - Page 08-1. Interpretation; Section 020 - Authority (Westman and Newman)	The City Council delegates to the Community Development Director and the Director's designees the authority, <u>in accordance with 17.08.040</u> , to interpret the meaning and applicability of all provisions in the Zoning Code".	
1 Edit	Chapter 17.12.030.C - Page 12-3. Zoning Districts and Map; Zoning Map, Subsection C - Location	The Zoning Map is kept, maintained, and updated electronically by the Community Development Department, and is available for viewing by the public at the Department. And on the official City of Capitola website"	
1 Edit	Chapter 17.16.010.B.2 - Page 16-1. Specific (Westman)	B.2. Multi-Family Residential (RM) Zoning District - Housing in the RM zoning district is will be carefully designed to enhance Capitola's unique identity and to minimize impacts on adjacent land uses and structures".	
1 Edit	Chapter 17.16.030.A. - Page 16-3. Development Standards and Site Requirements (Westman)	Add language to clarify that Site requirements are for purposes of future subdivisions. Existing legal lots of record may be developed including substandard lots.	
1 Edit	Chapter 17.16.030.A. Page 16-3. Table 1716-2. (Westman)	Add front yard setback for garage in table. It is listed under 17.16.030.B.3 but would be easier for reader to also be included in the table. Add garage reference under Additional Standards column (17.16.030.B.3). Chapter 17.16.030.A. Table 1716-2.	
1 DISCUSS	Chapter 17.16.030. A – Page 16-3. General Standards – Single Family and Multi-Family Zoning Districts	Table 17.16-2: Development Standards in the R-1 and RM Zoning Districts – discuss min lot size	
1 DISCUSS	Chapter 17.16.030.B.2 Page 16-4. Front Setbacks in Riverview Terrace (Westman)	<ul style="list-style-type: none"> <li>Define distance of neighboring properties. Current code states 500 feet. This is too vast.</li> <li>Staff suggested modification: "Within the areas shown in Figure 17.16-1, the Planning Commission may approve a reduced front setback to reflect match existing front setbacks on of neighboring properties within 100 feet on the same side of the street. The reduced front setback shall in all cases be no less than 10 feet."</li> </ul>	
1 DISCUSS	Chapter 17.16.030.B.2. Page 16-5. Front Setbacks in Riverview Terrace (Westman)	<ul style="list-style-type: none"> <li>General comment that the sidewalk exempt designations should be updated to make sure they are valid and appropriate. The sidewalk exempt map should be made available for the public.</li> </ul>	
1 Edit	Chapter 17.16.030.3.A - Page 16-5 - Garage Setback (Smith)	Clarify. Should garage setback be measured from property line or setback rather than building wall?	
1 DISCUSS	Chapter 17.16.030.7. Page 16-7. Plate Height in Side Setback Areas.	This is from the existing code but should be removed due to the new allowance for narrow lots not to have a second story setback. The setback exception is listed under 16.16.030.B.5.	
1 DISCUSS	17.16.030.B.8.a(1) Page 16-7. Decks and Balconies (Westman)	Discuss distance of setbacks for administrative review of upper floor decks and balconies. Proposed at 10 feet from property line and 20 feet from single-family dwelling	
1 DISCUSS	Chapter 17.16.030.C.2. Table 17.16-4 "Usable Open Space in RM Zoning District. Footnote 2. (Westman)	Footnote 2 – "Roof terraces and roof gardens may provide up to 50 percent of the required common open space area" – This applies to the Common Open Space minimum area requirement of 15%. Common open space is accessible to all residents of a multi-family development. Request to discuss.	
DISCUSS	Chapter 17.20 - Page 20-1 - Mixed Use Zoning District (Westman)	We should discuss separating the MU-V and MU-N districts. The goals and development standars for the two districts are different and the current chpater is confusing.	
1 Edit	Chapter 17.20.010.B.2 - Page 20-1. Specific. (Westman)	2 - Development in the MU-N zoning district is will be carefully designed to complement its surrounding and minimize impacts on neighboring properties".	

1 Edit	Chapter 17.20.010.B - Page 20-1. Purpose of the Mixed Use Zoning Districts; Subsection B (Welch)	Suggest renaming to follow nomenclature. 1 - Village Mixed Use (MU-V) change to "Mixed Use - Village" Zoning District"; 2 - "Neighborhood Mixed Use (MU-N) change to "Mixed Use - Neighborhood" Zoning District"
1 Edit	Chapter 17.20.020.A. Permitted land uses. Table 17.20.020 page 20-3 (Staff)	Vacation rental. Reference See Chapter 17.40.030"
1 DISCUSS	Chapter 17.20.030 – Page 20-4. Development Standards Table 17.20-2 – Development Standards in the Mixed Use Zoning Districts (Newman)	Remove parcel width & depth. They do not work.
DISCUSS	Chapter 17.20.30.A - Page 20-4 General Development Standards (Smith)	How do we meet the new minimum parcel dimensions and maximum front setbacks today? How many nonconforming structures are we creating with these new specifics?
1 DISCUSS	29) Chapter 17.20.030.C. Page 20-5 General Design Standards. (Westman)	Section C should not apply to residential development.
1 DISCUSS	Chapter 17.20.030.C.5 – Page 20-8 – Parking Location and Buffers (Smith)	Standard may prevent residential on-site parking under living. Example 321 Capitola Ave
1 Edit	Chapter 17.20.030.D.1 - (page 20-9) - Setbacks in the MU-V Zoning District (Welch)	The Planning Commission way may modify or waive this requirement upon finding that:"
1 Edit	Chapter 17.20.030. D.1 – Page 20-9. Setbacks in the MU-V Zoning district	Loosen standard building within 0-10' of property line.
1 DISCUSS	Chapter 17.20.030.E – Page 20-10. Setbacks in the MU-N Zoning District	Should not apply to residential. "Front setback areas for commercial and mixed use buildings in the MU-N Zoning District
1 Edit	Chapter 17.20.30.F Page 20-10 - Height and FAR Standards for the Village Hotel (Westman)	Request legal review to ensur this is not spot zoning
DISCUSS	Chapter 17.24 - Commercial and Industrial Zoning Districts (Westman)	The autoplaaza should be an overlay zone to eliminate automobile repairs, used car sales, etc. on 41st avenue.
1 Edit	Chapter 17.24.010.B. Page 24-1 - Regional Commercial (C-R) Zoning Districts (Westman)	Office, medical, and residential uses are restricted <del>in prime retail locations</del> to protect the long-term economic vitality of the corridor. There is no definition for "prime retail location".
1 Edit	Chapter 17.24.020 Permitted Land Use - Page 24-2 (Westman)	Table 17.24-1 - Permitted Land Uses in Commercial and Industrial Zoning Districts. Footnote 5. Permitted only on a mixed use site with the residential use secondary to the primary commercial uses on the site. Residential uses on the site are limited to less than 50 percent of the floor area of buildings on the site. Residential uses shall be located and designed to maintain a primarily commercial character and function of the site." - reword for clarity.
1 Edit	Chapter 17.24-1 - Page 24-2 - Land Use Table	Need to define custom manufacturing vs. light manufacturing.
1 Edit	Chapter 17.24.030.D.2 - Page 24-6 - Daylight Plane (Westman)	Figure 17.24-2 - Residential Transitions - Daylight Plane - Include in MU-N district
Edit	Chapter 17.24.030.B. - Page 24-5 - Front and Street Side Setbacks in CR and CC. (Westman)	Inconsistent with the sign ordinance setbacks for monument signs.
Edit	Chapter 17.24.030.D.2 and Figure 17.24.2 - Page 24-6 - Daylight plane (Smith)	There is a conflict. Text says Daylight Plane is 20' high. Figure shows 25' high.
Edit	Chapter 17.28.010.B.5 - Page 28-1 - Visitor Serving - General	add (VS-G)
25 Edit	15)Chapter 17.28.030 - Visitor Serving Land Use Regulation Table 17.28-1: Permitted Land Uses in the Visitor Serving Zoning Distcts Page 28-3 (Westman)	Schools, Public or Private - Subzone VS-G - Draft code: Conditional Use. Suggest Change to Prohibit. VS Subzones - Typo. Top of columns should be "VS-G, R, SB, MC, ES"  Footnote 10 - Events may not exceed 10 days; Comment - Long but reflects current code. Footnote 11 - Limited to single one-day event per year; Suggest modifying to two-days. Current rule prohibits Car Show during the summer months (Commissioner Smith also raised this issue)

26 Edit	Chapter 17.28.040.A. Page 28-5. Standards in the Visitor Serving Zoning District (Westman)	Table 17.28-2: Development Standards in the Visitor Serving Zoning Districts - Add heights for subzones. Staff comment: as written, the new code reflects the existing code. The individual subzones do not have special height standards. Table 17.28 says that all new subdivision in the Village or any other Visitor Serving location can have a building height of 30 feet. The other section on Village height says that you can only have 30 feet is you have a 5/12 pitch or greater. Which is correct?
27 Edit	Chapter 17.32.020.C - Page 32-1. Visitor Accommodations in New Brighton State Beach (Westman)	Section sets maximum intensity of three units per gross lot area. State regulated. Check with Coastal Commission if we can remove from code.
28 Edit	Chapter 17.32.020.E - Page 32-3 Public Parking in the Coastal Zone (Westman)	Not necessary to have in zoning code. Remove section
29 DISCUSS	Chapter 17.36 – Planned Development Zoning District (Westman)	Request discussion of PD
DISCUSS	Chapter 17.36.040.G - Page 36-4 - Substantial Public Benefit Defined (Westman)	Planning commission should discuss Substantial Public Benefit Definitions as they apply to Planned Developments
30 Edit	Chapter 17.36.060.B. 1-3 – Page 36-2. Application Submittal & Review (Newman)	Clarify two-step process and that preliminary approval does not give development rights.
Edit	Chapter 17.40.020.G - Page 40-3 - Income Restrictions (Westman)	Rewrite to make the requirement clear.
31	Chapter 17.40.20.I.3(a-f) – Page 40-5 – Design Standards – Pedestrian Orientation (Westman)	This is more restrictive than underlying zoning. Suggest removing.
32 DISCUSS	Chapter 17.40.20.I.5 – Page 40-6 - Affordable Housing Open Space. (Westman)	This is more restrictive the open space standard for multi-family. In general, affordable housing development standards should either be equal to the zoning regulation or less stringent as an incentive.
33 Edit	Chapter 17.40.020.L - Page 40-7 - AH Overlay - Additional Application Requirements (Westman)	An application for an affordable housing development within the -AH overlay zone shall be filed and reviewed in compliance with Chapter 17.112 (Permit Application & Review) - wrong reference. Katie's comment. Susan there must be a mix up. 17.112 is the permit application and review section. I'd suggest removing your comment or redirect if I got the wrong reference.
Edit	Chapter 17.40.030.E.5 - Page 40-8 - Permit Revocation (Smith)	after a Minor Permit is reevoked, the permit holder may <u>not</u> reapply for a new permit <u>for one year after revocation</u>
34 Edit	Chapter 17.44.020.G – Page 44-3 – Major Public Works Facility. (Westman)	Justify raising number based on value amount. Check coastal acknowledgment.
35 Edit	Chapter 17.44.040.J.1 – Page 44-9 – Temporary Events (Westman)	“The event will not occur between the Saturday of Memorial Day weekend through Labor Day, or if proposed in this period will be of less than <del>one two</del> day in duration including setup and take-down;” – change to 2 days (car show)
36 Edit	Chapter 17.44.070. I – Page 44-9. Conversion of Existing Multi-Unit Residential Structures (Newman)	“The conversion of any existing multi-unit residential structure to a <del>time-share</del> <u>condominium</u> project, estate, or use as defined in Section 11212 of the Business and Professions Code”.
Edit	Chapter 17.44.080 - Page 44-10 - Coastal Boundary (Smith)	Should note where the "Capitola Permit and Appeal Jurisdiction Map" can be found or at least identify Zone A and Zone B on a map in the Zoing Code fro eference
37 Edit	Chapter 17.44.110.A – Page 44-13 - Public Notice and Hearing – Planning Commission Review (Westman)	Check reference to 17.148 Correct reference
38 Edit	Chapter 17.44.120.B – Page 44-14 – Coastal Overlay Zone – Findings for Approval (Westman)	Remove finding B for views.
39 Edit	3) Chapter 17.48.020. B – Page 48-2. Height Exceptions: Table 17.48-1: Allowed Projections Above Height Limits (Smith)	“Flagpoles not over 8 inches in <u>width/ diameter</u> ”.
40 Edit	Chapter 17.48.030. A – Page 48-2. Setback Measurement - Figure 14.48-2: Setback Measurement (Smith)	Add note to “See specific zones for required zone setbacks”
41 Edit	Chapter 17.48.030. D – Page 48-4. Accessory Structures in Setback Areas (Smith)	<ul style="list-style-type: none"> <li>• Modify. Keep 4. Pool setback as is.</li> <li>• Add a separate line for hot tub with 2 foot setback.</li> </ul>

43 DISCUSS	Chapter 17.52.020.A.3 - Page 52-1 - All Accessory Structures (Smith)	Should all Accessory Structures be allowed basic electric (light) fixture and outlet without additional requirements for design review and floor area calculation. Also reference in Chapter 17.7.20 page 120-3)	
44 Edit	Chapter 17.52.020.A.4 –Page 52-1. All Accessory Structures (Smith) Chapter 17.52.020.A.6 – All Accessory Structures (Westman)	Is three feet necessary? Check with Building official and remove if ok Make distinction, can you use as office but not as a dwelling? Clarify –	“Accessory structures may not be designed or used for <u>human habitation</u> as a second dwelling unit, except in those applications or secondary dwelling units consistent with section 17.74 (Secondary Dwelling Units)” Need definition for human habitation
45 Edit	Chapter 17.52.020.B.1 – Table 17.52.1 – Page 52-2 (Westman)	Is this consistent with Issues and Options direction?	Issues and Options Direction: Secondary Structure in Rear Yard o Decrease rear yard setback from 8 feet to 4 feet. o Maintain 17.15.140.G “The width of detached garages or carports in the rear yard is limited to twenty-one feet. The height is limited to fifteen feet (nine feet to the top of the wall plate) for secondary structures located a minimum of 8 feet from the rear property line. However, the planning commission may approve an exception to allow additional height if necessary to match the architectural style of the existing primary structure.” o ADD: Secondary Structures less than 8 feet from the side yard may not exceed 12 feet in height. o Maintain required 2 foot landscape buffer between driveway and property line. o Maintain front setback (40 feet), side yard setback (3 feet) and setback from primary structure (3 feet) o Add statement in residential zoning districts an existing garage located within the required setback areas are legal non-conforming structures that may be updated but the non-conformity may not be expanded.
46 Edit			
47 DISCUSS	9) Chapter 17.52.020.B.1 – Page 52-2. Development Standards. Table 17.51-1: Accessory Structure Standards in Residential Zoning Districts (Smith)	Could you have an apartment on top of a garage if the garage was not located in setbacks?	
48 Edit	Chapter 17.56.020 - Page 56-1 - Coastal permit	Make sure to reference this chapter in the Coastal Zone	
49 Edit	Chapter 17.60.030.B.2 – Page 60-2 – Decorative Features and Materials (Smith)	Edit to be consistent with allowance of 10' Trellis.	“Decorative arches and other similar features above an entry walkways may be up to <del>8</del> 10 feet in height within a required front and exterior side setback”
50 Edit	Chapter 17.64.030.D - Table 17.64-1 - Page 64 (Westman)	Tannery Gulch Riparian Corridor setback is from Riparian Corridor not the oak woodland vegetation. Previous error in code that should be removed.	“50 feet from outer edge of riparian and oak woodland vegetation”
51 Edit	Chapter 17.64.040 - Page 64-3 - Soquel Creek and Lagoon (Westman)	There was a previous allowance for docks that is not in the existing code or the update. Suggest adding standard.	
52 Edit	Chapter 17.64.050 – Page 64-3 – butterfly habitat (Westman)	Add “Rispin”/Soquel Creek to better describe area.	“The following standard applies to both the Rispin/Soquel Creek and the Escalona...”
53 Edit	Chapter 17.68.020.B.1 - Page 68-2 - Geological Report (Westman)	Too specific. Make more general. Report reference will likely change over the years.	
54 Edit	Chapter 17.72.060. A – Page 72-4. Landscape Standard: General Standards (Newman)	Should clarify that the standards are only required subject to 17.72.020 A-C. “The following standards shall be in compliance within all zoning districts within applicable development as outlined in 17.72.020 A-C”	
55 Edit	Chapter 17.74.040.i.1 - Page 74-3- Alley Orientation	<ul style="list-style-type: none"> <li>• <del>Alley</del> Orientation”</li> <li>• This is within existing code; suggest to remove alley orientation and update with language that reflects finding 17.74.050.G for orientation.</li> </ul>	
56 Edit	Chapter 17.76.020 – Page 76-1 – Applicability (Westman)	Add description after applicability title stating that section applies to 3 different development scenarios.	“This section applies to administration of several development scenarios including: new structures and uses, replacement of existing uses, and expansions and enlargements.

57 DISCUSS	Chapter 17.76.030.A – Table 17.76-1 – Page 76-2 - Required Parking Spaces – Mixed Use Zoning Districts	Request discussion of parking for mixed use.	
	Chapter 17-76.030.A (page 76-2) Parking in Mixed Use Zoning Districts (Welch)	Table 17.76-1: Required on-site Parking in Mixed Use Zoning Districts i.Rename Village Mixed Use" to "Mixed Use - Village" AND "Rename "Neighborhood Mixed Use" to "Mixed Use - Neighborhood"	
58 Edit			
59 DISCUSS	Chapter 17.76.030.B – Table 17.76-2 – Page 76-3 - Required Parking Spaces – Other Zoning Districts (Westman)	Secondary Dwelling Units should require a 3rd parking space. Discussion requested.	
60 Edit	Chapter 17.76.040.B.1 – Figure 17.60-1 – Page 76-7 - Parking in Front Setback Area in R-1 (Westman and Smith)	10 feet too narrow; change to 20 ft. wide max. (Westman and Smith) also limits perpendicular parking (Smith)	Reflect existing code with max width of 40% of lot width up to a maximum of 20 feet. Narrow lots may have a minimum of 14' driveway width.
61 Edit	Chapter 17.76.040.B.2 0 Page 76-7 - Other Zoning Districts (Smith)	MU-N – address parking in front yard in mixed use neighborhood; Clarify to allow limited area of parking that may be in the front yard.	
62 Edit	Chapter 17.76. 050. C.2 – Page 76-10. Off-site Parking (Newman)	Typo. “On Off-site parking shall be located within a reasonable distance of the use it is intended to serve, as determined by the Planning Commission”.	
63 Edit	Chapter 17.76. 050. C.3 – Page 76-10. Off-site Parking (Newman)	A <del>covenant record-deed restriction or other legal instrument</del> , approved by the City Attorney, shall be filed with the County Recorder”	
64 DISCUSS	Chapter 17.76.040.C.3 – Page 76-8 – Location of Parking MU-V Zoning District (Westman)	Track ordinances. Why does the code require off-site parking in village for historic? If they have adequate space we should allow more onsite parking for residences.	
65 DISCUSS	Chapter 17.76.040.D – Page 76-8 – Large Vehicle Storage in the R-1 Zoning District (Westman)	Add maximum width	
66 DISCUSS	Chapter 17.76. 040. D – Page76-8. Large Vehicle Storage in the R-1 Zoning District	Too restrictive, suggest removing second sentence	
67 Edit	Chapter 17.76.040.E.1 Page 76-10 - Valet Parking (Westman)	Code states to be staffed at all times. Only needs to be staffed when business is open	Revise "Valet parking lots must be staffed <u>when business is open</u> at all times by an attendant who is authorized and able to move vehicles"
68 DISCUSS	Chapter 17.76.050.D.1 Shared Parking (page 76-10) (Welch and Newman)	Discuss the exclusion of residential land uses from shared parking (Welch) Too rigid (Newman)	
69 Edit	Chapter 17.76.050.D.2 Shared Parking (page 76-10) (Welch)	Clarify that parking study is required. Deposit paid by applicant and study contracted by City, reviewed by Community Development Director, and ultimately approved by Planning Commission	
70 DISCUSS	Chapter 17.76.050. G.5 – Page 76-11. Transportation Demand Management Plan	Clarify program coordination	
71 DISCUSS	Chapter 17.76.050.G – Page 76-11 - Transportation Demand Management Plan (Westman)	Add standards for parking studies	
72 DISCUSS	Chapter 17.76.050.H – Page 76-11 - Transit Center Credit (Westman)	Discuss	Discussed on 3/3/2016
73 DISCUSS	Chapter 17.76.060.H – Page 76-15 - Pedestrian Access (Westman)	Applicable to village? Discuss.	
74 Edit	Chapter 17.76.070 – Page 76-16 – Parking Lot Landscaping (Westman and Smith)	Add exceptions (Westman) Add flexibility to regulate canopy without requiring too many trees. (Smith)	
75 Edit	Chapter 17.76. 080. H – Page 76-19. Bicycle Parking Cover	Allow flexibility for creative designer and function	
76 DISCUSS	Chapter 17.80.050.A.3 - Page 80 - 4 - Flag Signs (Westman)	Discuss new allowance for flag signs	
77 DISCUSS	Chapter 17.80.060.F - Page 80-6 - Digital display and electronic reader board signs (Westman)	Discuss. Possible use to show number of parking places.	
78 DISCUSS	Chapter 17.80.070.C - Page 80-6 - Illumination (Westman)	Discuss neon signs. Beer signs.	
79 DISCUSS	Chapter 17.80.080.B. 7 - Monument Signs limit to 4 tenants (Westman)	Max limit of 4 tenants on Monument sign	
80 DISCUSS	Chapter 17.80.080.F.1 - Page 80-9 - Window Signs (Westman)	What is legal to regulate?	
81 DISCUSS	Chapter 17.80.080.G.13 - Page 80-11 - Sidewalk signs in MU-V zoning district	Suggest removing max limit of sidewalk signs for fairness.	

82 DISCUSS	Chapter 17.80.110. - Page 80-17 - Temporary Signs (Westman)	Discussion	
83 Edit	Chapter 17.84.030 – Page 84-3 - Authority to Maintain (Westman)	“The Director may add or remove structures from the list based on input from the State Certified Architectural Historian <del>and the City Historian”</del>	
84 DISCUSS	Chapter 17.88.030.J - Page 88-2 - Public Art (Westman)	Already required. Must go beyond requirement	Discussed on 3/3/2016. Reword/strengthen language in 17.88.020. Add to descriptions of allowable benefits.
85 DISCUSS	Chapter 17.92 - Page 92-1 - Non-Conforming Parcels, Uses, and Structures (Westman)	Discussion	
86 DISCUSS	Chapter 17.92.080.C.2 - Page 92-7 - Substantial Demolition (Smith)	Discussion on removal of substantial demolition	Remove the substantial demolition. Instead, require all additions to a non-conforming structure to be approved by Planning Commission and limit additions to 50% of existing non-conforming structure.
87 DISCUSS	Chapter 17.96.020. B – Page 96-2 – Household Pets (Westman and Smith)	Limit max number. (Suggest 10 total)	Add maximum of 4 of each type of pet with a maximum of 8 pets total.
88 Edit	Chapter 17.96. 020. C.1 – Page 96-2. Chickens	Location of Chicken Coops; not in front yard or exterior street	Add minimum lot size of 5000 sf. Location of coops shall specify they are not allowed in front or side yard. Must be located behind primary structure. Allowed within rear yard. Keep 20 feet requirement from dwelling units on adjacent properties.
89 Edit	Chapter 17.96.020.E – Page 96-2 – Prohibited Animals (Westman)	Add ducks	Add the word ducks as follows “1. Roosters, fowl other than chickens and ducks, goats ...
90 DISCUSS	Chapter 17.96.100. Page 96-9 Permanent Outdoor Displays (Welch)	Permanent Outdoor Displays will become a management/code enforcement issue. Do we want to create a path to allow these in the code or prohibit?	Do not allow in the MU-V. Add that permanent outdoor display requires approval of a conditional use permit by Planning Commission. Add that vending machines are not allowed as permanent outdoor displays. Make sure it is clear in draft code that redbox and vending machines located outside a building require a CUP for an accessory use. Define discretionary review.
91 Edit	Chapter 17.96.100.D – Page 96-9 – Standards for permanent outdoor display (Westman)	Add standard for location on private property and not allowed in public R.O.W.	Clarify
92 Edit	Chapter 17.96.110.D.1 – Page 96-11 – Prohibited Lighting (Westman)	What is a drop down lens? Clarify or remove.	Better define drop down lenses and input image
93 DISCUSS	20) Chapter 17.96.180 – Page 96-16. Temporary Sidewalks Dining (Welch)	Conversion of on-street parking might need discussion - probably OK as is, but do we want to add any limitations to times and/or presence of street closures/events?	Do not allow in MU-V. Within other commercial zones allow with tighter regulations.
94 Edit	Chapter 17.96.180.B.4.e - Temporary Sidewalk Dining (page 96-17) (Welch)	Furniture and Signage Location; e - Is the allowance for signs on awnings and umbrellas consistent with the sign section of the code?	
95 Edit	Chapter 17.96.180.B.7 -Temporary Sidewalk Dining (page 96-18) (Welch)	Hours of Operation - Add days of week: Sidewalk dining may occur between 7 a.m. and 10 p.m. 7 days a wee	Specify within tighter regulations.
96 DISCUSS	Chapter 17.96.200 – Page 96-20 – Unattended Donation Boxes (Westman)	Discussion	
97 Edit	Chapter 17.108. 030 – Page 108-1. Review and Decision Making; Table 17.108-1: Review and Decision Making Authority (Smith)	Define "Reasonable Accommodations" under Other Approvals	
99 DISCUSS	Chapter 17.120. 030. B. 5 –Page 120-3. Single-Family Exemptions (Smith)	Remove "electricity"	
100 Edit	Chapter 17.156. 070. C. 5 – Page 156-3. Minor Changes (Smith)	"A feature of the project that was a specific consideration of approval." Does this mean if we talk about it at the public hearing it fits?	
101 Edit	Chapter 17.156.080. C.3 – Page 156-5. Extension of Time (Smith)	Define '...up to expiration date of a valid tentative for projects...' What is a valid tentative?	
102 Edit	Chapter 17.160.020. B.3 – Page 160-2. "B" Terms (Smith)	Basement – portion below grade	
103 Edit	Chapter 17.160. 020. H – Page 160-7. "H" Terms (Smith)	<ul style="list-style-type: none"> <li>• Home Day Care</li> <li>i. "Home day care facilities, large" means a day care home facility supervising 8 persons or less 9 to 14 persons.</li> <li>ii. "Home day care facilities, small" means a day care home facility supervising 9 to 14 persons 8 persons or less.</li> </ul>	

#	LOCATION IN DRAFT CHANGE	REQUESTED DISCUSSION	IMPLEMENTATION
2	Chapter 17.16.030.B.2 Page 16-4. Front Setbacks in Riverview Terrace (Westman)	<ul style="list-style-type: none"> <li>Define distance of neighboring properties. Current code states 500 feet. Draft code states neighboring properties. Request to identify appropriate area.</li> </ul>	Modify language of 17.16.030.B.2 to state “the Planning Commission may approve a reduced front setback to reflect existing front setbacks of properties within 100 feet on the same side of the street”
3	Chapter 17.16.030.B.2. Page 16-5. Front Setbacks in Riverview Terrace (Westman)	<ul style="list-style-type: none"> <li>General comment that the sidewalk exempt designations should be updated to make sure they are valid and appropriate. The sidewalk exempt map should be made available for the public.</li> </ul>	Map will be made available to public.
4	Chapter 17.16.030.7. Page 16-7. Plate Height in Side Setback Areas.	This is from the existing code but should be removed due to the new allowance for narrow lots not to have a second story setback. The setback exception is listed under 16.16.030.B.5.	Remove standard for plate height in side setback areas.
5	17.16.030.B.8.a(1) Page 16-7. Decks and Balconies (Westman)	Discuss distance of setbacks for administrative review of upper floor decks and balconies. Proposed at 10 feet from property line and 20 feet from single-family dwelling	Require Planning Commission review of a Design Permit for all upper floor decks and balconies except when facing a street or adjacent to a public open space.
6	Chapter 17.16.030.C.2. Table 17.16-4 “Usable Open Space in RM Zoning District. Footnote 2. (Westman)	Footnote 2 – “Roof terraces and roof gardens may provide up to 50 percent of the required common open space area” – This applies to the Common Open Space minimum area requirement of 15%. Common open space is accessible to all residents of a multi-family development. Request to discuss.	Require Planning Commission approval with findings or criteria for approval of roof terraces and roof gardens utilized as common open space

#	LOCATION IN DRAFT CHANGE	REQUESTED DISCUSSION	IMPLEMENTATION
7	Chapter 17.20 - Page 20-1 - Mixed Use Zoning District (Westman)	We should discuss separating the MU-V and MU-N districts. The goals and development standards for the two districts are different and the current chapter is confusing.	Chapter to be revised to include subchapters separating the MU-V from the MU-N as appropriate
Added	Chapter 17.20.020 - Page 20-2 - Land Use Regulations.	Planning Commission discussed permit for daycare and secondary dwelling units relative to review process.	Change Secondary Dwelling Units to require minor use permit in the land use table. Keep daycare as minor use permit
8a MU-V	Chapter 17.20.030 – Page 20-4. Development Standards Table 17.20-2 – Development Standards in the Mixed Use Zoning Districts (Newman)	Remove parcel width & minimum dimensions in MU-V. They do not work.	Mixed use village Minimum lot size and lot dimensions will be removed.
8b MU-N	Chapter 17.20.030 – Page 20-4. Development Standards Table 17.20-2 – Development Standards in the Mixed Use Zoning Districts (Newman)	Remove parcel width & minimum dimensions in MU-N. They do not work.	Mixed Use Neighborhood. CHANGE: Minimum Parcel Size 3200 square feet; Minimum Width 40 feet; and minimum depth 80 feet. Add note that these standards apply only to new parcels within a subdivision application
Add	Chapter 17.20.030 – Page 20-4. Development Standards Table 17.20-2 – Development Standards in the Mixed Use Zoning Districts	Concern for minimum lot size and dimensions on existing parcels.	Add language the minimum lot size and dimensions only apply to new subdivisions.
9	Chapter 17.20.30.A - Page 20-4 General Development Standards (Smith)	How do we meet the new minimum parcel dimensions and maximum front setbacks today? How many nonconforming structures are we creating with these new specifics?	



#	LOCATION IN DRAFT CHANGE	REQUESTED DISCUSSION	IMPLEMENTATION
10	29) Chapter 17.20.030.C. Page 20-5 General Design Standards. (Westman)	Section C should not apply to residential development.	Design standards are geared to commercial. Clarify that standards do not apply to the village-residential overlay district. Revise standards so the design requirements for the MU-V and MU-N are treated differently.
11	Chapter 17.20.030.C.5 – Page 20-8 – Parking Location and Buffers (Smith)	Standard may prevent residential on-site parking under living. Example 321 Capitola Ave	Modify so standard only applies to the MU-V district.
Add	Chapter 17.20.030.D - Setback in MU-V	shall to may	Modify language to allow more of the building to be setback from the front property line.
12	Chapter 17.20.030.E – Page 20-10. Setbacks in the MU-N Zoning District (Westman)	Should not apply to residential. “Front setback areas for commercial and mixed use buildings in the MU-N Zoning District	Maximum setback in the MU-N is 25 feet. These standards will be separated to clarify the differences between the zones. Standard will not be changed.
Add	Chapter 17.20.030.F Height and FAR Standards for the Village Hotel	Change heading to remove "the village hotel"	Change heading in 030.F to read “Height and FAR Standards for the Capitola Theater Site” and reference as such in the text.
13	Chapter 17.24 - Commercial and Industrial Zoning Districts (Westman)	The autoplaza should be an overlay zone to eliminate automobile repairs, used car sales, etc. on 41st avenue.	No change to draft code. Keep Vehicle Repair and Vehicle Sales and Rental as a Conditional Use in the CC and CR zones. And as Permitted within the Industrial zone.
13.B	Chapter 17.24 - Commercial and Industrial Zoning Districts (Westman)	Drive through. Should they be limited to Regional Commercial	Change: Limit drive through to regional commercial district. Prohibit from CC.

#	LOCATION IN DRAFT CHANGE	REQUESTED DISCUSSION	IMPLEMENTATION
14	Chapter 17.36 – Planned Development Zoning District (Westman)	Request discussion of PD	<p>Change: Modify process. Remove requirement of a preliminary development plan. Replace with a required conceptual review that is more informal. Within the conceptual review, require noticing, review by Planning Commission, and review by City Council. The rest of the process should remain as proposed.</p> <p>Add standard of 20,000 sf minimum parcel size to qualify for PD.</p> <p>Additional note: A separate section must be created in the code for Conceptual Reviews outlining purpose, process, and noticing.</p>
15	Chapter 17.36.040.G - Page 36-4 - Substantial Public Benefit Defined (Westman)	Planning commission should discuss Substantial Public Benefit Definitions as they apply to Planned Developments	Staff provided redline changes to better define substantial benefit, method to quantify substantial benefits, and improve descriptions of the options. The redlines were acceptable to the Planning Commission. Redlines will be incorporated into draft code.
16	Chapter 17.40.20.I.3(a-f) – Page 40-5 – Design Standards – Pedestrian Orientation (Westman)	This is more restrictive than underlying zoning. Suggest removing.	Remove 17.40.020.I.3 Pedestrian Orientation
17	Chapter 17.40.20.I.5 – Page 40-6 - Affordable Housing Open Space. (Westman)	This is more restrictive the open space standard for multi-family. In general, affordable housing development standards should either be equal to the zoning regulation or less stringent as an incentive.	No change to 17.40.020.I.5 Common Open Space

#	LOCATION IN DRAFT CHANGE	REQUESTED DISCUSSION	IMPLEMENTATION
Added	Chapter 17.40.030 Vacation Rental Use Overlay Zone. Development and Operations Standards. Added during Planning Commission hearing on April 18, 2016	Modification to Development and Operation standards based on recent Vacation Rental code enforcement sweep. Staff provided modifications during meeting.	Change: Replace proposed Development and Operations Standards with those provided during meeting. Within the permit revocation standard, change to clarify that CDD determination can be appealed to PC. Also remove "or for a greater time period as established by the Community Development Director.
18	Chapter 17.52.020.A.3 - Page 52-1 - All Accessory Structures (Smith)	Should all Accessory Structures be allowed basic electric (light) fixture and outlet without additional requirements for design review and floor area calculation. Also reference in Section 17.120.030.B.5 page 120-3)	Exception to one accessory structures to include allowance of electricity.
Added	Chapter 17.52.020.A.3 - Page 52-1 - All Accessory Structures	Discussion that accessory structures may be utilized as an office	The Commission also discussed that accessory structures may be utilized as an office and commented the standard shall remain that they are not for human habitation. This is confusing as an office would likely meet the definition of habitation. Reword to be clear that the space may not be utilized as a bedroom, sleeping area, and/or kitchen.
19	9) Chapter 17.52. 020. B.1 – Page 52-2. Development Standards. Table 17.51-1: Accessory Structure Standards in Residential Zoning Districts (Smith)	Could you have an apartment on top of a garage if the garage was not located in setbacks?	The answer to the question is yes, but not stated clearly in the code. Staff will clarify code (Section 17.74: Secondary Dwelling Units) that a 2 story secondary dwelling unit may include a garage in the first story.

#	LOCATION IN DRAFT CHANGE	REQUESTED DISCUSSION	IMPLEMENTATION
Added	Chapter 17.60 Fences and Walls:17.60.010.B	Exceptions to height	Add criteria for Planning Commission exceptions to address areas in which the fences are typically taller than normal. Example is Wharf Road.
Added	Chapter 17.60 Fences and Walls:17.60.070 Non-Conforming Fences and Walls	Concern for regulating replacement fences.	Remove non-conforming fences and walls. Also, allow fences to be replaced without a permit.
Added	Fences and Walls as encroachments into Side yard Table (17.48-2).	screening and decorative fences should be allowed in side and rear yard.	The Commission discussed allowed encroachments into setbacks. Directed to allow fences and walls to encroach into the side and rear yards that may be utilized as screening or decoration. Fences may encroach in front yard if at regulated height.
Added	Wood burning fireplace	Would like to discourage wood burning fireplaces do to environmental and health impacts	Add language that wood burning fireplaces are discouraged.
Added	Chapter 17.72.020. B – Applicability	Concern that requirement goes too far.	Remove B “additions that increase the floor area of a single-family dwelling by 10 percent or more” Add a second section under applicability to require Landscape that is removed during a remodel must comply with section 17.72.060 Landscape Standards.
Added	17.72.020.B	Applicability of maintenance requirements will be a challenge for single family homes	Applicability should also specify that only multi-family and commercial are subject to the Maintenance requirements.
Added	17.72.050.A.1	the allowance for outdoor dining areas and courtyards should also apply to single-family. Social features that support interactive communities.	17.72.050.A.2 allow residential to have outdoor dining areas and courtyards that count toward the landscape area requirements.

#	LOCATION IN DRAFT CHANGE	REQUESTED DISCUSSION	IMPLEMENTATION
Added	Table 17.72-1	Industrial requirement is incorrect and not in synch with 17.24-030.	Table 17.72-1 Minimum Landscape Area in Non-Residential Zoning Districts. Modify Industrial to remove “none” and add “As determined by the permit approval process” Also modify development standard table 17.24-030 to change the required 10% in the Industrial Zone to also state “as determined by the permit approval process”
Added		Plan should be plant in 2 sentences.	17.72.060.A.1 and A.3. The word “plan” should be “plants”. This edit is in two different lines. A.1 and A.3
Added	Chapter 17.74 Secondary Dwelling Units	Modify proposed regulations	<ol style="list-style-type: none"> <li>1. Add stipulation that only SDU is only allowed when there is one single family home on the property.</li> <li>2. Remove from MU-V zoning</li> <li>3. Require all 2 story secondary dwellings to get a conditional use permit</li> <li>4. Keep owner occupied requirement with an waiver for hardship</li> <li>5. Require an extra parking space for Secondary Dwelling Units</li> <li>6. Increase rear yard setback to 8 feet.</li> </ol>
20	Chapter 17.76.030.A – Table 17.76-1 – Page 76-2 - Required Parking Spaces – Mixed Use Zoning Districts (Westman)	Request discussion of parking for mixed use.	Remove unique standards for MU-N in table 17.76.030. MU-N will be included in other zoning districts table 17.76-2

#	LOCATION IN DRAFT CHANGE	REQUESTED DISCUSSION	IMPLEMENTATION
Added	17.76.020. C.1 Expansions and Enlargements. Discuss options to allow existing restaurants modest expansions within existing building footprint	Return with scenario of decreasing restaurant scenario in the Village for 300 sf for kitchen. What will be allowed in term of expansions if a commercial space has onsite parking? Bring back Mercantile example for existing restaurants. Figure out if there is a percentage that correlates for change in parking to allow existing businesses some flexibility to expand a little bit.	Current draft states “Additional parking is required to serve only the expanded or enlarged area”. Allow an exception for expansion of dining area up to 20% of the existing floor area of the business” Expansions include modification of internal layout to expand dining area, additions to restaurant within the existing footprint of the building, and new outdoor dining areas.” (Note: Commissioner Newman did not support the modification.)
Added	17.76.020.B.1 Replacing existing uses in Village. Discuss option to apply the standards of B.1. to restaurants	New restaurants replacing other land use in village	Conversions of any space from another land use to restaurants should be required to provide parking for the entire amount of parking required by the code, without a “credit” of the parking demand of the existing use. Make restaurants subject to same standard as 17.76.020.B.1 instead of B.2.
21	Chapter 17.76.030.B – Table 17.76-2 – Page 76-3 - Required Parking Spaces – Other Zoning Districts (Westman)	Secondary Dwelling Units should require a 3rd parking space. Discussion requested.	Require one additional space for secondary dwelling unit.
22	Chapter 17.76.040.C.3 – Page 76-8 – Location of Parking MU-V Zoning District (Westman)	Track ordinances. Why does the code require off-site parking in village for historic? If they have adequate space we should allow more onsite parking for residences.	Allow residential to provide parking onsite in the Village. Note: will require modification to LCP.

#	LOCATION IN DRAFT CHANGE	REQUESTED DISCUSSION	IMPLEMENTATION
23	Chapter 17.76.040.D – Page 76-8 – Large Vehicle Storage in the R-1 Zoning District (Westman)	Add maximum width	Add maximum width
24	Chapter 17.76. 040. D – Page76-8. Large Vehicle Storage in the R-1 Zoning District (Smith)	Too restrictive, suggest removing second sentence	Keep as drafted.
25	Chapter 17.76.050.D.1 Shared Parking (page 76-10) (Welch and Newman)	Discuss the exclusion of residential land uses from shared parking (Welch) Too rigid (Newman)	Remove D1. Parking Study should be done by the City and paid for by applicant.
27	Chapter 17.76.050.G – Page 76-11 - Transportation Demand Management Plan (Westman)	Add standards for parking studies	a. Shared Parking in MUN: 25% max decrease b. Transportation Demand Management Plan: 15% max decrease c. Transit Center: REMOVED d. Mixed Use Village: No decrease in parking standards allowed.
28	Chapter 17.76.050.H – Page 76-11 - Transit Center Credit (Westman)	Discuss	Remove Transit Center Credit
29	Chapter 17.76.060.H – Page 76-15 - Pedestrian Access (Westman)	Applicable to village? Discuss.	Leave as is
Added	Chapter 17.80 Signs.	Discussion on signs in the Mixed Use Village	Create a separate subchapter for sign standards in the Mixed Use Village.
Added	Chapter 17.80 Signs	City Installed Signs	Add exemption that City installed signs do not require permits within all zoning district. There is a section exempting VS, CF, and P/OS but the exemption should be Citywide.

#	LOCATION IN DRAFT CHANGE	REQUESTED DISCUSSION	IMPLEMENTATION
Added	Chapter 17.80.030. B	Permit Requirements - Sign Permits	Add all signs in the Mixed Use Village require Planning Commission approval.
30	Chapter 17.80.030.B - Flag Signs (Westman)	Discuss new allowance for flag signs	Remove #3 a and b for Flags
31	Chapter 17.80.060.F - Page 80-6 - Digital display and electronic reader board signs (Westman)	Discuss. Possible use to show number of parking places.	Exempt city installed signs. Create allowance within parking garages similar to gas station allowance
Added	Chapter 17.80.030.B Signs Allowed Without Permits. A. Types of Signs.	Discussion on restaurant menu signs.	Modify #12 to add "Restaurant menu signs, with a maximum area of 3 square feet <u>attached to building.</u> "
32	Chapter 17.80.070.C - Page 80-6 - Illumination (Westman)	Discuss neon signs. Beer signs.	Modify 17.80.070.C.1 to read "Non-residential signs may be internally or externally illuminated. Internal illumination is permitted only when the portion of the sign that appears illuminated is primarily the sign lettering, registered trademark, or logo. Add this standard to 17.80.090.B.7.C Do not allow internal illumination in the Mixed Use Village.  Do not prohibit neon signs. Modify so all neon signs require Planning Commission approval.



#	LOCATION IN DRAFT CHANGE	REQUESTED DISCUSSION	IMPLEMENTATION
Added	Chapter 17.80.070.D.1.	Edit	Reword 17.80.070.D.1 to “Except for <u>interior</u> windows signs, all permanent signs shall...” Reword 17.80.070.D.1 to “The design of signs, including its shape, features, materials, colors, and textures, shall be compatible with the design character of the development or use it identifies <u>and will not have an adverse effect on the character and integrity of the surrounding area.”</u> ”
Added	Chapter 17.80.070.F.1.b.	Exceptions for signs in the public right-of-way.	Staff Clarification: This exception is necessary to carry out City Council Policy Number I -17 for Capitola Village Street Banner Program policy. The policy allows nonprofit groups, public and governmental agencies, and public information campaigns to display promotional street banners for charitable, educational, arts, community, and public interest activities, regulations, and events. Banners under this policy may be displayed only at the Capitola Avenue/Riverview Drive and Monterey Avenue/Park Place intersections.
Added	Chapter 17.80.80	Standards for Specific Types of Signs and 17.80.090 Sign Standards for zoning Districts	Combine these two sections so it is easier for the user. After each standard have a table that states the specifics for the zone. The back and forth is confusing.

#	LOCATION IN DRAFT CHANGE	REQUESTED DISCUSSION	IMPLEMENTATION
Added	Chapter 17.80.80	Standards for Specific Types of Signs	Sign Standards for Center Identification Signs and Directory Signs are missing from this section. Add Center Identification Sign Standards. Make sure to include that one freestanding sign per frontage. More specifically, if there is a monument sign along the frontage a center identification sign is not allowed. Add Directory Sign standards to reflect the existing code.
Added	Chapter 17.80.080.A	Awning Signs	In the MU-V and MU-N: Awning signs only allowed on Valance. Anything beyond requires Planning Commission approval. In the CR and CC district: Specify either/or. An awning may have signage in either the valance or the sign face. Not both. To go beyond the limits within the sign valance or sign face, Planning Commission approval is required.
Added	<u>Chapter 17.80.080.B</u>	Monument Sign	The setbacks for monument signs may be in conflict with the CR zone. Review 17.24.030B and make sure they are not in conflict.
Added	<u>Chapter 17.80.080.B</u>	Monument Sign	Increase max area of Monument Sign in MU-N to 16 ft. Keep MU-V at 12 feet.
33	Chapter 17.80.080.B. 7 - Monument Signs limit to 4 tenants (Westman)	Max limit of 4 tenants on Monument sign	Can go beyond with PC approval. This allowance will have to be noted within the section on what the Planning Commission can approve.

#	LOCATION IN DRAFT CHANGE	REQUESTED DISCUSSION	IMPLEMENTATION
Added	Chapter 17.80.080.C and 17.80.090.	Wall Signs	Planning Commission Direction: Keep max area in MU-V at 0.5 sf per linear foot of storefront. Increase MU-N to 1 sf per linear foot of storefront. Max area is 36 square feet otherwise requires Planning Commission approval. Add corner lot standard of two signs.
Added	Chapter 17.80.080.D and 17.80.090.C	Projecting Signs	Add Commercial standards to Industrial Zoning District. Decrease Maximum area to 8 sf in the commercial and industrial zoning districts.
Added	Chapter 17.80.080.E	Gas and Service Station Signs	Allow gas station to list services within permitted signs for propane and ATMs to avoid all the additional small a-frame signs that do not comply with code. Create a standard for the new gas station sign like 1 square foot to advertise ATM and 1 Square foot to advertise propane. These signs must be attached to a sign or structure.
34	Chapter 17.80.080.F	Window Signs	Remove maximum of 1 sign per window. Modify 17.80.090.B.2.h.1 to 30% of window
35	Chapter 17.80.080.G.13 - Page 80-11 - Sidewalk signs in MU-V zoning district (Newman)	Suggest removing max limit of sidewalk signs for fairness.	Remove 30 maximum in village. 17.80.080.G.13.
Added	Chapter 17.80.090.A.4.	Edit to emphasize compatibility	Add J "The signs will not have a significant adverse effect on the character and integrity of the surrounding area."

#	LOCATION IN DRAFT CHANGE	REQUESTED DISCUSSION	IMPLEMENTATION
Added	Chapter 17.80.090.A.4.F	Internal Illumination in Village	Specify that internal illumination is not allowed in the village. Backlit signs are allowed. Only allowed in MU-N. Add specific lighting restricts for maximum lumens or foot-candles for all illuminated signs.
Added	Chapter 17.80.090.B.5	Auto dealership signs	Elaborate on the allowances within the dealerships for more frequent temporary sign permits, signs on light poles throughout the autoplaaza, etc.
Added	Chapter 17.80.090.B.6	Low Visibility Areas. Definition	Define Low Visibility Areas
Added	17.80.090.B.7.C		to read "Non-residential signs may be internally or externally illuminated. Internal illumination is permitted only when the portion of the sign that appears illuminated is primarily the sign lettering, registered trademark, or logo
Added	Chapter 17.80.090 A4 and B7 and C4	Design Standards	Add zone name in title. Design Standards for Commercial, Design Standards for MU-N, etc.
Added	Chapter 17.80.090.D:	<u>Visitor Serving</u>	This should not apply to VS overlay. Clarify only in Visitor Serving not in Overlay. As noted previously, signs installed by the City are exempt citywide. Reference in beginning of chapter and remove.

#	LOCATION IN DRAFT CHANGE	REQUESTED DISCUSSION	IMPLEMENTATION
36	Chapter 17.80.110. - Page 80-17 - Temporary Signs (Westman)	Discussion	<ol style="list-style-type: none"> <li>1. Delete Small Commercial Signs within Use Restriction delete “non-residential uses only” and write in Autodealerships on Autoplaza Drive Only. Create a row for Auto Dealers that allows these signs and allows balloon. Increase frequency of allowance.</li> <li>2. Remove Balloon Signs</li> <li>3. Under Construction Site Signs- Residential change Use Restrictions to Residential Uses only.</li> <li>4. For Construction Site Signs both residential and non-residential – change maximum duration to state “to certificate of occupancy”</li> <li>5. For Construction Site Signs non-residential and for sale lease and rent sign non-residential – require that the signs are smaller in the Central Village.</li> <li>6. For Sale, Lease, and Rent Signs, Non-residential specify 1 per property on site and revise maximum duration to state “180 days; director may approve extensions” remove 90 days.</li> <li>7. For open house add allowance that 1 on property and one on a different private property with the consent of private property owner.</li> </ol>
37	Chapter 17.88.030.J - Page 88-2 - Public Art (Westman)	Already required. Must go beyond requirement	Discussed on 3/3/2016. Reword/strengthen language in 17.88.020. Add to descriptions of allowable benefits.
38	Chapter 17.92 - Page 92-1 - Non- Conforming Parcels, Uses, and Structures (Westman)	Discussion	

#	LOCATION IN DRAFT CHANGE	REQUESTED DISCUSSION	IMPLEMENTATION
Added	Chapter 17.80.130.F.1	Master Sign Program	Planning Commission Direction: Remove “color” and remove provided that the signs contribute to a consistent visual theme within the property.
Added	Chapter 17.80.140	Non-conforming signs. A. Continuation	Planning Commission: Add to continuation that if there is a remodel (more than 50%) the non-conforming sign must come into compliance.
Added	17.88.030 Allowable Benefits.	Move Central Village from MU-V chapter to 17.88.	Move Central Village Theater Site to section 17.88
Added	17.88.030 Allowable Benefits	Discussion on revised allowable benefit list	Clarify 17.88.030.D what “sidewalk oriented commercial uses” means. The idea is to bring the building up to the street/sidewalk. Update to be clearer of intent. Revised list is improvement.
Added	17.88.040 Available Incentives	Move the Central Village Theater Site from MU-V to 17.88	Move the Central Village Theater Site to 17.88
Added	17.88.060	Application Submittal and Review	The organization of this section is confusing. Revise A: The application must go before Planning Commission for a recommendation to the City Council. Remove B. Separate chapter for Conceptual Review will be added
Added	17.88.080	Findings	Delete Finding C. Add finding that the Public Benefit exceeds the benefits required by the zoning code or any other provisions of local, state, or federal law.
Added	17.92.010	Purpose	Move purpose E after purpose C
Added	17.92.050.B	Cessation of Use	Define “Cessation of Use” and specify what operating and non-operating means. Business closed. Extend to 180 consecutive days.

#	LOCATION IN DRAFT CHANGE	REQUESTED DISCUSSION	IMPLEMENTATION
Added	17.92.070.C.3	Measures to Compensate for Impacts	Language is too weak. Change provide a community benefit to “neighborhood” benefit. For examples include: reducing number of residential
39	Chapter 17.92.080.C.2 - Page 92-7 - Substantial Demolition (Smith)	Discussion on removal of substantial demolition	Remove the substantial demolition. Instead, require all additions to a non-conforming structure that require a design permit to be approved by Planning Commission and limit additions to 50% of existing non-conforming structure.
Added	17.92.080.D	Replication of Single Family Dwellings	Change replication to reconstruction. Keep recreates the original building footprint, mass, floor area, height, and roof lines but allow deviation in arrangement of doors, windows, and exterior finishes. Similar to reconstruction as included under 17.92.080.E.2 which allows minor changes to arrangement of doors, windows, and rooflines. Add finding that modification to the non-conforming structure preserves the beach cottage character of the city.
	17.92.080 D.5	Finding reference	Reference to findings should be 17.92.090.
40	Chapter 17.96.020. B – Page 96-2 – Household Pets (Westman and Smith)	Limit max number.	Add maximum of 4 of each type of pet with a maximum of 8 pets total.
Added	17.96.020.C. Chickens	Chickens	Add minimum lot size of 5000 sf. Location of coops shall specify they are not allowed in front or side yard. Must be located behind primary structure. Allowed within rear yard. Keep 20 feet requirement from dwelling units on adjacent properties.
Added	17.96.020.D. Prohibited Animals	Prohibited Animals	Add the word ducks as follows “1. Roosters, fowl other than chickens and ducks, goats ...

#	LOCATION IN DRAFT CHANGE	REQUESTED DISCUSSION	IMPLEMENTATION
Added	17.96.040	Home Occupation	Minor Edit: 17.96.040.B.2 Sales and Displays. Add the word onsite as follows. "Products may not be sold onsite directly to customers..."
Added	17.96.060.A	Large Commercial Land Uses: Purpose and Applicability	Keep standard for applicability at 12,000 sf and remove 20,000 sf. Also, reinsert previous code exception for commercial properties within a 300,000 sf shopping center.
41	Chapter 17.96.100. Page 96-9 Permanent Outdoor Displays (Welch)	Permanent Outdoor Displays will become a management/code enforcement issue. Do we want to create a path to allow these in the code or prohibit?	Do not allow in the MU-V. Add that permanent outdoor display requires approval of a conditional use permit by Planning Commission. Add that vending machines are not allowed as permanent outdoor displays. Make sure it is clear in draft code that redbox and vending machines located outside a building require a CUP for an accessory use. Define discretionary review.
Added	17.96.110.D.1	Outdoor Lighting. Prohibited Lighting. Drop-down lenses.	Better define drop down lenses and input image
Added	17.96.140	Residential Mixed Use Development in Commercial Zoning Districts	Move to CC and CR Zones. Remove 17.96.120.C.7 retail location. Reword 17.96.120.C.10 to clarify parking along curb. Clarify if this is parking along frontage. Curb suggests public street parking.
added	17.96.150	Self-storage should have a dash in the regional commercial zone. Update 17.96.150 to reflect that the self storage are only applicable in the CC.	



#	LOCATION IN DRAFT CHANGE	REQUESTED DISCUSSION	IMPLEMENTATION
42	20) Chapter 17.96.180 – Page 96-16. Temporary Sidewalks Dining (Smith)	Conversion of on-street parking might need discussion - probably OK as is, but do we want to add any limitations to times and/or presence of street closures/events?	Staff to add tighter regulations.
Added	17.96.180	Temporary Sidewalk Dining	Do not allow in MU-V. Within other commercial zones allow with tighter regulations.
Added			
43	Chapter 17.96.200 – Page 96-20 – Unattended Donation Boxes (Westman)	Discussion	
44	Chapter 17.120. 030. B. 5 –Page 120-3. Single-Family Exemptions (Smith)	Remove "electricity"	
45	Chapter 17.148.020 Notice of Hearing (Smith)	The requirement for prominent posting on site is not listed, shouldn't it be? Also would like to discuss electronic posting to social media sites / email as alternatives to supplement newspaper posting under item 3. Would like to add notice requirements to conceptual review hearings so that the affected public is aware of these discussions.	

# **List of Addresses included in Capitola 1986 Architectural Survey**

## ARCHITECTURAL SURVEY LIST OF STRUCTURES

CAPITOLA VILLAGE AREA

- ❖ 207 California Ave.
- ❖ 208 California Ave.
- ❖ 211 California Ave.
- ❖ 214 California Ave.
- ❖ 104 Cherry Ave.
- ❖ 106 Cherry Ave.
- ❖ 202 Cherry Ave.
- ❖ 204 Cherry Ave.
- ❖ 206 Cherry Ave.
- ❖ 302 Cherry Ave.
- ❖ 307 A Cherry Ave.
- ❖ 307 B Cherry Ave.
- ❖ 317 Cherry Ave.
- ❖ 325 Cherry Ave.
- ❖ 321 Cherry Ave.
- ❖ Cherry Ave. & Fanmar Way.
- ❖ 4980 Cliff Dr.
- ❖ 199 – 231 Esplanade
- ❖ Depot Hill Stairway (off Monterey Ave.
- ❖ 110 – 122 Esplanade (Six Sisters)
- ❖ 210 Esplanade
- ❖ 105 Fanmar Way
- ❖ 107 Fanmar Way
- ❖ 201 Fanmar Way
- ❖ 310 Fanmar Way
- ❖ 103 – 121 Lawn Way (Lawn Way Cottages)
- ❖ 104 – 120 Lawn Way (Lawn Way Cottages)
- ❖ 120 Monterey Ave. (Capitola Theater)
- ❖ 200 Monterey Ave.
- ❖ 201 Monterey Ave.
- ❖ 204 Monterey Ave.
- ❖ 206 Monterey Ave.
- ❖ 211 Monterey Ave.
- ❖ 216 Monterey Ave.
- ❖ 221 Monterey Ave.
- ❖ 223 Monterey Ave.
- ❖ 229 Monterey Ave.
- ❖ 240 Monterey Ave.
- ❖ 122 – 126 San Jose Ave.
- ❖ 212 San Jose Ave.
- ❖ 216 San Jose Ave.
- ❖ 217 San Jose Ave.
- ❖ 221 San Jose Ave.
- ❖ 222 San Jose Ave.
- ❖ 223 San Jose Ave.
- ❖ 224 San Jose Ave.
- ❖ 204 Stockton Ave.
- ❖ 206 Stockton Ave.
- ❖ 212 Stockton Ave.
- ❖ 216 Stockton Ave.
- ❖ 219 Terrace Way
- ❖ Stockton Ave. Bridge (At Wharf Rd.)

## ARCHITECTURAL SURVEY LIST OF STRUCTURES

### DEPOT HILL AREA

- ❖ 250 Monterey Ave (Southern Pacific Railroad Depot)
- ❖ 106 Central Ave.
- ❖ 108 Central Ave.
- ❖ 107 Central Ave.
- ❖ 109 Central Ave.
- ❖ 110 Central Ave.
- ❖ 112 Central Ave.
- ❖ 113 Central Ave.
- ❖ 116 Central Ave.
- ❖ 117 Central Ave.
- ❖ 119 Central Ave.
- ❖ 122 Central Ave.
- ❖ 123 Central Ave.
- ❖ 124 Central Ave.
- ❖ 125 Central Ave.
- ❖ 126 Central Ave.
- ❖ 201 Central Ave.
- ❖ 202 Central Ave.
- ❖ 203 Central Ave.
- ❖ 204 Central Ave.
- ❖ 205 Central Ave.
- ❖ 206 Central Ave.
- ❖ 210 Central Ave.
- ❖ 214 Central Ave.
- ❖ 104 Cliff Ave.
- ❖ 106 Cliff Ave.
- ❖ 108 Cliff Ave.
- ❖ 112 Cliff Ave.
- ❖ 114 Cliff Ave.
- ❖ 116 Cliff Ave.
- ❖ 118 Cliff Ave.
- ❖ 1620 El Salto Dr.
- ❖ Escalona Dr. Extension
- ❖ 210 Escalona Dr.
- ❖ 706 Escalona Dr.
- ❖ 710 Escalona Dr.
- ❖ 104 Fairview Ave.
- ❖ 106 Fairview Ave.
- ❖ 107 Fairview Ave.
- ❖ 108 Fairview Ave.
- ❖ 110 Fairview Ave.
- ❖ 102 Grand Ave.
- ❖ 108 Grand Ave.
- ❖ 110 Grand Ave.
- ❖ 114 Grand Ave.
- ❖ 116 Grand Ave.
- ❖ 302 Grand Ave.
- ❖ 203 Hollister St.
- ❖ 206 Hollister St.
- ❖ 212 Hollister St.
- ❖ 217 Hollister St.
- ❖ 113 Oakland St.
- ❖ 216 Oakland St.
- ❖ 107 Saxon Ave.
- ❖ 106 Saxon Ave.
- ❖ 109 Saxon Ave.
- ❖ 112 Saxon Ave.
- ❖ 114 Saxon Ave.
- ❖ 117 Saxon Ave.
- ❖ 205 Saxon Ave.
- ❖ 207 Saxon Ave.
- ❖ 212 Saxon Ave.
- ❖ 101 Sacramento St.

## ARCHITECTURAL SURVEY LIST OF STRUCTURES

### RIVERVIEW AREA

- ❖ 404 A Bluegum Ave.
- ❖ 404 B Bluegum Ave.
- ❖ 406 Bluegum Ave.
- ❖ 408 Bluegum Ave.
- ❖ 107 Riverview Ave.
- ❖ 305 Riverview Ave.
- ❖ 311 Riverview Ave.
- ❖ 310 Riverview Ave.
- ❖ 312 Riverview Ave.
- ❖ 314 Riverview Ave.
- ❖ 315 Riverview Ave.
- ❖ 317 Riverview Ave.
- ❖ 317A Riverview Ave.
- ❖ 320 Riverview Ave.
- ❖ 321A Riverview Ave.
- ❖ 321B Riverview Ave.
- ❖ 323 Riverview Ave.
- ❖ 327 Riverview Ave.
- ❖ 326 Riverview Ave.
- ❖ 329 Riverview Ave.
- ❖ 333 Riverview Ave.
- ❖ RR Trestle
- ❖ 397 Riverview Ave.
- ❖ 399 Riverview Ave.
- ❖ 401 Riverview Ave.
- ❖ 403 Riverview Ave.
- ❖ 409 Riverview Ave.
- ❖ 410 Riverview Ave.
- ❖ 415 Riverview Ave.
- ❖ 417 Riverview Ave.
- ❖ 418 Riverview Ave.
- ❖ 419 Riverview Ave.
- ❖ 422 Riverview Ave.
- ❖ 423 Riverview Ave.
- ❖ 425 Riverview Ave.
- ❖ 429 Riverview Ave.
- ❖ 432 Riverview Ave.
- ❖ 435 Riverview Ave.
- ❖ 437 Riverview Ave.
- ❖ 439 Riverview Ave.
- ❖ 441 Riverview Ave.
- ❖ 443 Riverview Ave.
- ❖ 414 Riverview Dr.
- ❖ 415 Riverview Dr.
- ❖ 416 Riverview Dr.
- ❖ 418 Riverview Dr.
- ❖ 421 Riverview Dr.
- ❖ 422 Riverview Dr.
- ❖ 501 Riverview Dr.
- ❖ 505 Riverview Dr.
- ❖ 505A Riverview Dr.
- ❖ 506 Riverview Dr.
- ❖ 509 Riverview Dr.
- ❖ 509A Riverview Dr.
- ❖ 510 Riverview Dr.
- ❖ 511 Riverview Dr.
- ❖ 610 Riverview Dr.
- ❖ 1400 Wharf Rd. (Capitola Wharf)
- ❖ 1500 Wharf Rd. (Venetian Court)
- ❖ 1720 Wharf Rd.
- ❖ 1810 Wharf Rd.
- ❖ 1820 Wharf Rd.
- ❖ 2000 Wharf Rd.
- ❖ 2011 Wharf Rd.

## ARCHITECTURAL SURVEY LIST OF STRUCTURES

### CAPITOLA ROAD AREA

- ❖ 3117 Capitola Rd.
- ❖ Brown Bulb Rd. via clares St.
- ❖ 3130 Capitola Rd.
- ❖ 3600 Capitola Rd.
- ❖ 3744 Capitola Rd.
- ❖ 3754 Capitola Rd.
- ❖ 4375 Capitola Rd.
- ❖ 4940 Capitola Rd.
- ❖ 4510 Capitola Rd.
- ❖ 4570 Capitola Rd.
- ❖ 4705 Crystal St.
- ❖ 4805 Crystal St.
- ❖ Emerald St. at 49<sup>th</sup> Ave. (Tankhouse without tank)
- ❖ 4555 Emerald St.
- ❖ 4855 Emerald St.
- ❖ 4870 Emerald St.
- ❖ 5005 Garnet St.
- ❖ 5040 Garnet St.
- ❖ 1521 Lincoln Ave.
- ❖ 1535 Lincoln Ave.
- ❖ 1555 Lincoln Ave.
- ❖ 1565 Lincoln Ave.
- ❖ 3875 Melton St.
- ❖ 1400 Prospect Ave.
- ❖ 1410 Prospect Ave.
- ❖ 1440 Prospect Ave.
- ❖ 1470 Prospect Ave.
- ❖ 1480 Prospect Ave.
- ❖ 1490 Prospect Ave.
- ❖ 1530 Prospect Ave.
- ❖ 1540 Prospect Ave.
- ❖ 1545 Prospect Ave.
- ❖ 1570 Prospect St. (Lent House)
- ❖ 4800 Topaz St.
- ❖ 1361 38<sup>th</sup> Ave.
- ❖ 1821 38<sup>th</sup> Ave.
- ❖ 1725 38<sup>th</sup> Ave.

## ARCHITECTURAL SURVEY LIST OF STRUCTURES

### CAPITOLA AVENUE AREA

- ❖ 101 Capitola Ave.
- ❖ 109 Capitola Ave.
- ❖ 110 Capitola Ave.
- ❖ 115 Capitola Ave.
- ❖ 122 Capitola Ave.
- ❖ 201 Capitola Ave.
- ❖ 207 Capitola Ave.
- ❖ 307 Capitola Ave.
- ❖ 314 Capitola Ave.
- ❖ 324 Capitola Ave.
- ❖ 403 Capitola Ave.
- ❖ 410 Capitola Ave.
- ❖ 421 Capitola Ave.
- ❖ 425 Capitola Ave.
- ❖ 427 Capitola Ave.
- ❖ 429 Capitola Ave.
- ❖ 505 Capitola Ave.
- ❖ 511 Capitola Ave.
- ❖ 529 Capitola Ave.
- ❖ 602 Capitola Ave.
- ❖ 605 Capitola Ave.
- ❖ 609 Capitola Ave.
- ❖ 617 Capitola Ave.
- ❖ 911 Capitola Ave.
- ❖ 919 Capitola Ave.
- ❖ 412 Bay Ave.
- ❖ 501 Bay Ave.
- ❖ 800 Bay Ave.
- ❖ 501 Beulah Dr.
- ❖ 501 Beverly Dr.
- ❖ 307 Hill St.
- ❖ 308 Hill St.
- ❖ 405 Pine St.
- ❖ 407 Pine St.
- ❖ 715 Rosedale Ave.

# **Planning Commission Historic Resources Subcommittee's Draft Lists of Historic Resources**



**DRAFT**

## Capitola Historic Resources

## Level One Residences

1. Van Syckle House (Kriege home), 202 Cherry Street.
2. Six Sisters, 110-122 Esplanade.
3. 221 San Jose Avenue (Capt. George Mitchell).
4. 104 Cliff Avenue (Arthur).
5. 106 Cliff Avenue (Hooper).
6. 108 Cliff Avenue (Pahle).
7. 112 Cliff Avenue (Pfister-Lynn).
8. 118 Cliff Avenue (Gregory).
9. El Salto Resort structures
10. 104 Fairview (Woodhouse).
11. 102 Grand Avenue (Steiger House).
12. 108 Grand Avenue (Pieper House).
13. 919 Capitola Avenue (Averon House)
14. 1500 Wharf Road (Venetian Court)
15. 2000 Wharf Road (Rispin Mansion)
16. 1570 Prospect Avenue (Lent House)

**DRAFT**

**DRAFT**

## Capitola Historic Resources

### Level One Commercial

1. Craft Gallery building, 122-126 San Jose Avenue.
2. Capitola Theater, 120 Monterey Avenue.
3. Hihn Superintendent Building, 201 Monterey Avenue.
4. St. John the Baptist Episcopal Church, 216 Oakland Avenue.
5. Capitola City Hall, 1949, 127 Monterey Avenue.
6. Capitola Amusement Company building (Zelda's), 203 The Esplanade.

**DRAFT**

**DRAFT**

Capitola Historic Resources  
Level II Residences

1. 317-325 Cherry Avenue cottages.
2. 221 Monterey Avenue (Reynold's boarding house).
3. 114 Cliff Avenue (Reding house).
4. 307 Hill Street (Nutter)
5. 315 Riverview Avenue (apartments)
6. 397 and 399 Riverview Avenue (windmill)
7. 1530 Prospect Avenue (Helen Palmer)
8. Lawn Way cottages (unrenovated)
9. Old Riverview Court, 315 and 317 Riverview Avenue.
10. 320 and 326 Riverview Avenue (original Riverview bungalows)
11. 106 Cherry Avenue, unaltered cottage built in "flats"
12. 221 and 224 San Jose Avenue, original Camp Capitola.
13. Former Riverview Terrace real estate office, Riverview Avenue at Riverview Drive and Bluegum.

**DRAFT****DRAFT**

**DRAFT**

Capitola Historic Resources  
Level II Commercial

1. Capitola Depot, 250 Monterey Avenue.
2. Casa Blanca Apartments, 240 Monterey Avenue.
3. Averon Carriage House, 911 Capitola Avenue.
4. Shadowbrook Restaurant, 1750 Wharf Road.
5. Oscar Classen Pharmacy and Post Office, 122 Capitola Avenue.
6. Capitola Amusement Co., 203 The Esplanade, (Zelda's).
8. Aries Arts building, 201 Capitola Avenue. (Xerxa Groceries)
9. 1933 Stucco shops, 207-212 Capitola Avenue.
10. Apartments, 403 Capitola Avenue, stucco, unaltered.

**DRAFT**

DRAFT

Capitola Historic Resources  
Level III Commercial

1. Capitola Hotel, 210 The Esplanade (Hertel building).
2. Complex with stucco exterior, 110 Capitola Avenue.
3. Stockton bridge business building, 103 Stockton Avenue
4. Mercantile building, 115 San Jose Avenue (Bowling Alley).
5. Boathouse complex, 221 The Esplanade (Margaritaville).
6. Harry Hooper's Real Estate Office building, 220 Capitola Avenue.
7. Canepa building, 104 Stockton Avenue.
8. Capi's Coffee Express cottage, 311 Capitola Avenue.

DRAFT

**City of Capitola  
Historic Structures List  
2005**

**Key**

A: National Register of Historic Places /California Register

B: Capitola Register of Historic Features, adopted by the Capitola City Council, 2000

C: Historic Context Statement, adopted by Capitola City Council, 2004

D: Capitola Architectural Survey, 1986

E: Depot Hill Feasibility Study by Franklin Maggi, 2004

**Bay Avenue**                      **Key**                      **State Historical Resource Status Code**

412 Bay Avenue                      D                      7 N

501 Bay Avenue                      D                      7 N

800 Bay Avenue                      C, D                      7 N

**Beverly Drive**

501 Beverly Drive                      D                      7 N

**Blue Gum Avenue**

404 A&B Blue Gum Avenue                      A, D                      1 D

406 Blue Gum Avenue                      A, D                      1 D

408 Blue Gum Avenue                      A, D                      1 D

**California Avenue**

207 California Avenue                      D                      7 N

208 California Avenue                      D                      7 N

211 California Avenue                    D                    7 N

**Capitola Avenue**

101 Capitola Avenue                    C, D                    7 N

109 Capitola Avenue                    A, D                    1 D

110 Capitola Avenue                    C, D                    7 N

122 Capitola Avenue                    D                    7 N

201 Capitola Avenue                    C, D                    7 N

216 Capitola Avenue                    C                    7 R

307 Capitola Avenue                    C, D                    7 N

314 Capitola Avenue                    C, D                    7 N

324 Capitola Avenue                    D                    7 N

403 Capitola Avenue                    D                    7 N

410 Capitola Avenue                    D                    7 N

421 Capitola Avenue                    A, D                    1 D

425 Capitola Avenue                    A, D                    1 D

427 Capitola Avenue                    A, D                    1 D

429 Capitola Avenue                    D                    7 N

505 Capitola Avenue                    D                    7 N

511 Capitola Avenue                    D                    7 N

529 Capitola Avenue                    C, D                    7 N

602 Capitola Avenue                    D                    7 N

605 Capitola Avenue                    D                    7 N

Attachment: 2005 Historic Resources List (1512 : Zoning Code Update)

609 Capitola Avenue	C, D	7 N
911 Capitola Avenue	C, D	7 N
919 Capitola Avenue	C, D	7 N

**Capitola Road**

3600 Capitola Road	D	7 N
4375 Capitola Road	D	7 N
4570 Capitola Road	D	7 N
4670 Capitola Road	C	7 R
4940 Capitola Road	D	7 N
4910 Capitola Road	D, C	7 N

**Central Avenue**

106 Central Avenue	D, E	7 N
107 Central Avenue	D, E	7 N
108 Central Avenue	D, E	7 N
109 Central Avenue	D, E	7 N
110 Central Avenue	D, E	7 N
116 Central Avenue	C, D, E	7 N
117 Central Avenue	D, E	7 N
119 Central Avenue	D, E	7 N
122 Central Avenue	D, E	7 N
123 Central Avenue	D, E	7 N

Attachment: 2005 Historic Resources List (1512 : Zoning Code Update)



124 Central Avenue	D, E	7 N
126 Central Avenue	D, E	7 N
201 Central Avenue	D, E	7 N
202 Central Avenue	D, E	7 N
203 Central Avenue	D, E	7N
204 Central Avenue	D, E	7 N
205 Central Avenue	D, E	7 N
206 Central Avenue	D, E	7 N
210 Central Avenue	D, E	7 N
214 Central Avenue	D, E	7 N
220 Central Avenue	D, E	7 N

**Cherry Avenue**

104 Cherry Avenue	C, D	7 N
106 Cherry Avenue	C, D	7 N
202 Cherry Avenue	C, D	7 N
204 Cherry Avenue	D	7 N
206 Cherry Avenue	D	7 N
307 A&B Cherry Avenue	D	7 N
317 Cherry Avenue	C, D	7 N
321 Cherry Avenue	D	7 N
325 Cherry Avenue	C, D	7 N
Cherry Avenue Retaining Wall	B	5S1

Attachment: 2005 Historic Resources List (1512 : Zoning Code Update)

**Cliff Avenue**

104 Cliff Avenue	D, E	7N
106 Cliff Avenue	D, E	7N
108 Cliff Avenue	D, E	7N
112 Cliff Avenue	C, D, E	7N
114 Cliff Avenue	D, E	7N
116 Cliff Avenue	D, E	7N
118 Cliff Avenue	C, D, E	7N
Hihn Park Stairs	B	5S1

**Cliff Drive**

4980 Cliff Drive	C, D	7 N
------------------	------	-----

**Crystal Street**

4705 Crystal Street	D	7 N
4805 Crystal Street	D	7 N

**El Camino Medio**

Depot Hill Staircase	B, D	5S1
----------------------	------	-----

**El Salto Drive**

205 El Salto Drive	E	7 N
206 El Salto Drive	E	7 N
208 El Salto Drive	E	7 N

Attachment: 2005 Historic Resources List (1512 : Zoning Code Update)

620 El Salto Drive C, D 7 N

**Emerald Street**

4555 Emerald Street C, D 7 N

4855 Emerald Street D 7 N

Tank house  
Emerald Street at 49<sup>th</sup> Avenue D 7 N

**Escalona Drive**

210 Escalona Drive D 7 N

710 Escalona Drive D 7 N

**Esplanade**

110 Esplanade A, C, D 1 D

112 Esplanade A, C, D 1 D

118 Esplanade A, C, D 1 D

120 Esplanade A, C, D 1 D

210 Esplanade D 7 N

199-231 Esplanade D 7 N

Lagoon Pool  
231 Esplanade B 5S1

**Fairview Avenue**

104 Fairview Avenue D, E 7 N

106 Fairview Avenue D, E 7 N

Attachment: 2005 Historic Resources List (1512 : Zoning Code Update)

108 Fairview Avenue D, E 7 N

110 Fairview Avenue D, E 7 N

**Fanmar Way**

105 and 107 Fanmar Way C, D 7 N

201 Fanmar Way D 7 N

310 Fanmar Way D 7 N

**Garnet Street**

5040 Garnet Street D 7 N

**Grand Avenue**

102 Grand Avenue D, E 7 N

108 Grand Avenue D, E 7 N

110 Grand Avenue D, E 7 N

114 Grand Avenue D, E 7 N

116 Grand Avenue D, E 7 N

302 Grand Avenue D, E 7 N

**Hill Street**

307 Hill Street C, D 7 N

**Hollister Avenue**

203 Hollister Avenue D 7 N

206 Hollister Avenue D 7 N

Attachment: 2005 Historic Resources List (1512 : Zoning Code Update)

212 Hollister Avenue C, D 7 N

217 Hollister Avenue D 7 N

**Lawn Way**

104 (East) Lawn Way A, C, D 1 D

106 (East) Lawn Way A, C, D 1 D

114 (East) Lawn Way A, C, D 1 D

115 and 117 (East) Lawn Way A, C, D 1 D

116 Lawn Way A, C, D 1 D

130 (North) Lawn Way A, C, D 1 D

131 (North) Lawn Way A, C, D 1 D

133 (North) Lawn Way A, C, D 1 D

134 (North) Lawn Way A, C, D 1 D

**Lincoln**

1521 Lincoln Avenue D 7 N

1535 Lincoln Avenue D 7 N

1545 Lincoln Avenue D 7 N

1555 Lincoln Avenue D 7 N

**McCormick Avenue**

404 McCormick Avenue C 7 R

Attachment: 2005 Historic Resources List (1512 : Zoning Code Update)

**Monterey Avenue**

Monterey Avenue Palm Tree	B	5 S1
Monterey Avenue Retaining Wall	B	5 S1
120 Monterey Avenue	C, D	7 N
127 Monterey Avenue	A, C, D	1 D
131-133 Monterey Avenue	A, C, D	1 D
200 Monterey Avenue	D	7 N
201 Monterey Avenue	A, C, D	1 S
204 Monterey Avenue	D	7 N
206 Monterey Avenue	D	7 N
296 Monterey Avenue	D	7 N
211 Monterey Avenue	D	7 N
216 Monterey Avenue	C, D	7 N
221 Monterey Avenue	C, D	7 N
223 Monterey Avenue	D	7 N
229 Monterey Avenue	D	7 R
240 Monterey Avenue	C, D, E	7 N
250 Monterey Avenue	C, D, E	7 N
504 Monterey Avenue	C	7 N

**Oakland Avenue**

113 Oakland Avenue	D	7 N
216 Oakland Avenue	C, D	7 N

Attachment: 2005 Historic Resources List (1512 : Zoning Code Update)

**Pine Street**

405 Pine Street	C, D	7 N
407 Pine Street	C, D	7 N

**Prospect Avenue**

East Hill Pathway	B	5 S1
1400 Prospect Avenue	D	7 N
1410 Prospect Avenue	D	7 N
1470 Prospect Avenue	D	7 N
1530 Prospect Avenue	C, D	7 N
1540 Prospect Avenue	D	7 N

**Riverview Avenue**

305 Riverview Avenue	A, D	1 D
311 Riverview Avenue	A, D	1 D
314 Riverview Avenue	D	7 N
315 Riverview Avenue	C, D	7 N
317 & 317A Riverview Avenue	A, C, D	1 D
319 Riverview Avenue	A	1 D
321A & 321B Riverview Avenue	A, C, D	1 D
323 Riverview Avenue	A, D	1 D
326 Riverview Avenue	A, C, D	1 D
Union Pacific Railroad Trestle	A, B, C, D	1 D & 5S1

Attachment: 2005 Historic Resources List (1512 : Zoning Code Update)

397 Riverview Avenue	A, C, D	1 D
399 Riverview Avenue	A, C, D	1 D
401 Riverview Avenue	A, D	1 D
403 Riverview Avenue	D	7 N
409 Riverview Avenue	A, D	1 D
410 Riverview Avenue	D	7 N
415 Riverview Avenue	A, D	1 D
417 Riverview Avenue	A, D	1 D
418 Riverview Avenue	D	7 N
419 Riverview Avenue	D	7 N
422 Riverview Avenue	A, D	1 D
423 Riverview Avenue	D	7 N
425 Riverview Avenue	A, D	1 D
429 Riverview Avenue	A, D	1 D
432 Riverview Avenue	A, D	1 D
435 Riverview Avenue	A, D	1 D
437 Riverview Avenue	A, D	1 D
439 Riverview Avenue	A, D	1 D
441 Riverview Avenue	A, D	1 D
443 Riverview Avenue	A, D	1 D
<b>Riverview Drive</b>		
488 Riverview Drive	A, D	1 D

Attachment: 2005 Historic Resources List (1512 : Zoning Code Update)



489 Riverview Drive	A, D	1 D
494 Riverview Drive	D	7 N
495 Riverview Drive	D	7 N
496 Riverview Drive	D	7 N
498 Riverview Drive	D	7 N
501 Riverview Drive	A, D	1 D
506 Riverview Drive	A, D	1 D
507 Riverview Drive	A	1 D
509 & 509A Riverview Drive	A, C, D	1 D
510 Riverview Drive	A, D	1 D
610 Riverview Drive	D	7 N
611 Riverview Drive	C	7 N
<b>Rosedale Avenue</b>		
715 Rosedale Avenue	D	7 N
<b>San Jose Avenue</b>		
126 San Jose Avenue	C, D	7 N

Attachment: 2005 Historic Resources List (1512 : Zoning Code Update)

212 San Jose Avenue	D	7 N
217 San Jose Avenue	D	7 N
220 San Jose Avenue	C	7 N
221 San Jose Avenue	C, D	7 R
222 San Jose Avenue	D	7 N
223 San Jose Avenue	D	7 N
224 San Jose Avenue	D	7 N

**Saxon Avenue**

106 Saxon Avenue	D, E	7 N
107 Saxon Avenue	D, E	7 N
108 Saxon Avenue	E	7 N
109 Saxon Avenue	D, E	7 N
114 Saxon Avenue	D, E	7 N
117 Saxon Avenue	D, E	7 N
205 Saxon Avenue	D, E	7 N
206 Saxon Avenue	E	7 N
207 Saxon Avenue	D, E	7 N
208 Saxon Avenue	E	7 N
212 Saxon Avenue	D, E	7 N
217 Saxon Avenue	E	7 N

**Stockton Avenue**

Stockton Avenue Bridge	B, C, D	5 S1
------------------------	---------	------

Attachment: 2005 Historic Resources List (1512 : Zoning Code Update)

102 Stockton Avenue	C	7 R
103 Stockton Avenue	C	7 R
204 Stockton Avenue	D	7 N
212 Stockton Avenue	D	7 N
216 Stockton Avenue	D	7 N
 <b>Sunset Drive</b>		
719 Sunset Drive	C	7 R
 <b>Terrace Way</b>		
219 Terrace Way	C, D	7 N
 <b>Topaz Street</b>		
4800 Topaz Street	D	7 N
 <b>Wharf Road</b>		
1400 Wharf Road (Wharf)	A, B, C, D	1 D & 5S1
1500 Wharf Road (District)	A, C, D	1 D
1720, 1720A Wharf Road	A	1 D
1750 Wharf Road	D	7 N
1810 Wharf Road	C, D	7 N
1820 Wharf Road	D	7 N
2200 Wharf Road (District)	A, C, D	1 D
 <b>48<sup>th</sup> Avenue</b>		
1725 48 <sup>th</sup> Avenue	D	7 N

Attachment: 2005 Historic Resources List (1512 : Zoning Code Update)





## Chapter 17.114 – CONCEPTUAL REVIEW

### Sections:

- 17.114.010 Purpose
- 17.114.020 When Required/Eligibility
- 17.114.030 Review Authority
- 17.114.040 Application Submittal Requirements
- 17.114.050 Application Review
- 17.114.060 Environmental Review
- 17.114.070 Permit Streamlining Act
- 17.114.080 Noticed Public Meeting
- 17.114.090 Non-Binding Input

### 17.114.010 Purpose

This chapter describes the process for Conceptual Review of a proposed project. Conceptual Review allows an applicant to receive preliminary non-binding input from the Planning Commission and/or City Council on a proposed project prior to City action on a formal permit application.

### 17.114.020 When Required/Eligibility

- A. Planned Development Projects.** Conceptual Review is required for proposed Planned Development projects in accordance with Chapter 17.36 (Planned Development Zoning District).
- B. Other Projects.** Conceptual Review is not required for projects other than a Planned Development project, but may be requested by an applicant. Conceptual Review is intended for complex or controversial projects that would benefit from preliminary input prior to City action on a permit application. An applicant may also request conceptual review to receive input on policy interpretations and contextual community design options that would benefit from early input from the Planning Commission.

### 17.114.030 Review Authority

- A. Planned Development Projects.** Both the Planning Commission and the City Council shall provide input on a Conceptual Review application for a Planned Development project.
- B. Other Projects.**
  1. For a project other than a Planned Development project that requires Planning Commission approval, the Planning Commission shall provide input on the Conceptual Review application.
  2. For projects other than a Planned Development project that requires both Planning Commission and City Council approval, an applicant may request input on the Conceptual Review application from the Planning Commission, the City Council, or both.

### 17.114.040 Application Submittal Requirements

#### A. All Projects.

1. An applicant requesting Conceptual Review shall file an application with the Community Development Department on an official City application form.
2. Applications shall be filed with all required fees, information, and materials as specified by the Community Development Department. Application fees for Conceptual Review are subject to the requirements specified in Section 17.112.030 (Application Fees).

#### B. Planned Development Projects.

In addition to application materials required by paragraph 1 above, Conceptual Review applications for Planned Development projects shall also include the following:

1. A statement describing the proposed project and how it complies with the findings required for the approval of a Planned Development project in Section 17.36.080.G (Findings).
2. Project plans, diagrams, and graphics as needed to illustrate the overall development concept, including proposed land uses, buildings, circulation, open space, and any other significant elements in the project.

### 17.114.050 Application Review

#### A. Completeness Review.

The Community Development Department shall review each Conceptual Review application for completeness and accuracy. The Department may request additional information if necessary for consideration of the Planning Commission and/or City Council.

#### B. Staff Report.

The Community Development Department shall prepare a staff report describing the proposed project and including, where appropriate, an analysis of project compliance with applicable City policies and regulations. Staff reports shall be furnished to the applicant at the same time as they are provided to the review authority before consideration of the application.

### 17.114.060 Environmental Review

Conceptual Review applications are not defined as a project pursuant to the California Environmental Quality Act (CEQA) and as such are not subject to environmental review process as required by CEQA.

### 17.114.070 Permit Streamlining Act

Conceptual Review applications are not subject to the requirements of the California Permit Streamlining Act (Act). An application that receives Conceptual Review shall not be considered complete pursuant to the requirements of the Act unless and until the Director has received an application for approval of a development project, reviewed it, and determined it to be complete under Chapter 17.112 (Permit Application and Review).

**17.114.080 Noticed Public Meeting**

- A. Noticed Public Meeting Required.** The Planning Commission or City Council (“review authority”) shall consider a Conceptual Review application at a public meeting noticed in accordance with Section 17.148.020 (Notice of Hearing).
- B. Information Received.** At the meeting the review authority shall receive information from staff and the applicant and receive public comment on the proposed project.
- C. Preliminary Input.** The review authority shall provide the applicant with preliminary input on the proposed project, including the project compliance with applicable City policies and regulations.
- D. Input on Planned Development Projects.** For Planned Development projects, the review authority shall provide preliminary input on project compliance with findings required for the approval of a Planned Development project in Section 17.36.080.G (Findings).

**17.114.090 Non-Binding Input**

Review authority input on the Conceptual Review application shall not be construed as a recommendation for City approval or denial of the project. Any recommendation that results from Conceptual Review is advisory only and shall not be binding on either the applicant or the City.