

City of Capitola

Art & Cultural Commission

Tuesday July 11, 2023 – 5:30 PM

Council Chambers
420 Capitola Avenue, Capitola CA 95010

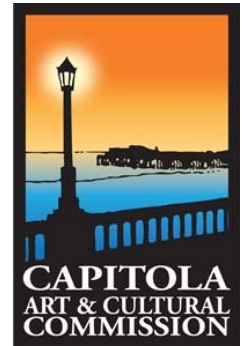

Remote Attendance: Council Member Clarke
Commissioner Cahalen Mandalay Bay
8021 Indian Creek Blvd 3950 S. Las Vegas Blvd Rm 11133
Kissimmee FL 34747 Las Vegas NV 89119

Chair: Roy Johnson

Vice Chair: Laurie Hill

Commissioners: Mary Beth Cahalen, Courtney Christiansen, Joe Clarke, Kelly Mozumder, James Wallace, Peter Wilk, Vacant Seat

Staff Representatives: Nikki Bryant LeBlond & Kelly Barreto

-
1. **Call to Order**
 2. **Additions and Deletions to the Agenda**
 3. **Public Oral Communication**
 4. **Approval of Minutes- Regular Meeting June 13, 2023**
 5. **General Business**
 - a. **Brown Act Training**
 - b. **Commissioner Recommendation**
 - c. **Begonia Comemorative Public Art Proposals**
 - d. **Program Expenses**
 - e. **Ukrainian Art in the Park**
 - f. **Plein Air**
 - g. **Capitola Wharf Enhancement Project**
 6. **Commissioner Reports**
 7. **Staff Reports**
 8. **Future Agenda Items**
 9. **Adjournment**

Agenda and agenda Packet Materials: The Art and Cultural Commission Agenda is available on the City's website: www.cityofcapitola.org on Friday prior to the Tuesday meeting. If you need additional information, please contact the City Hall Department at (831) 475-7300

American with Disabilities Act: Disability-related aids or services are available to enable persons with a disability to participate in this meeting consistent with the Federal Americans with Disabilities Act of 1990. Assisted listening devices are available for individual with hearing impairments at the meeting in the City Council Chambers. Should you require special accommodation to participate in the meeting due to a disability, please contact the City Clerk's office at least 24-hours in advance of the meeting at (831) 475-7300. In an effort to accommodate individuals with environmental sensitivities, attendees are requested to refrain from wearing perfumes and other scented products.

Appeals: Any person who believes that a final action of this advisory body has been taken in error may appeal that decision to the City Council. Appeals must be in writing and delivered to the City Clerk's Office within ten (10) working days from the time of the board's

decision. The notice of appeal shall set forth appellant's name, phone number, address to which notices may be sent to the appellant, and the grounds upon which the appeal is made.

City of Capitola

Art & Cultural Commission: Draft Minutes

Tuesday, June 13, – 6:30 PM

Council Chambers
420 Capitola Avenue, Capitola CA 95010

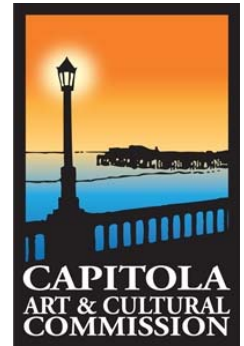

Chair: Roy Johnson

Vice Chair: Laurie Hill

Commissioners: Mary Beth Cahalen, Courtney Christiansen, Joe Clarke, Kelly Mozumder, James Wallace, Peter Wilk, Vacant Seat

Staff Representatives: Nikki Bryant LeBlond & Kelly Barreto

1. **Call to Order:**

The meeting was called to order at 6:32 PM. In attendance: Cahalen, Clarke, Hill, Mozumder, Wallace, Absent: Johnson, Christiansen, Wilk,

2. **Additions and Deletions to the Agenda**

Vice Chair Hill requested to move item 5.h to beginning of General Business agenda

Commissioner Cahalen inquired about the possibility of adding a plaque to commemorate Nathan Cross at the Seal Statue.

Vice Chair Hill requested to continue item 5.a to next regular meeting due to Chair Johnson's absence.

3. **Public Oral Communication** None

4. **Approval of Minutes- May 9, 2023**

Vice Chair Hill commented on the minutes and questioned how Commissioner Orantes resignation was recorded.

Motion to approve the Minutes with one change to add Commissioner Orantes as listed as resigned instead of absent: Council Member Clarke

Second: Commissioner Cahalen

Voting Yea: Commissioner Cahalen, Council Member Clarke, Vice Chair Hill, Commissioner Mozumder, Commissioner Wallace.

5. **General Business**

a. **Program Expenses**

Item continued to next regular meeting.

b. **Ukrainian Art in the Park**

Report given by Vice Chair Hill on updates of event planning and promotions.

Commissioner Cahalen commented on event posted and recommended the logo be changed to the Art & Cultural logo on poster.

Motion to approve: No Action Taken

c. **Village Decoration Policy: Banner Project**

Report given by Vice Chair Hill. Continue item to August meeting.

Motion to approve: No Action Taken

d. **Plein Air**

Report given by Vice Chair Hill and report updates to event planning. Subcommittee returned to online juried process which cost the City \$125 and then \$7 per applicant. Requested of the Commission to change the First and Second prize winning to \$1800 and \$1000 from public art fund. Staff will bring the revised budget to City Council on Consent Items.

Motion to approve update of Plein Air First Prize to \$1,800 and Second Prize to \$1,000 from the Public Art Fund: Commissioner Cahalen

Second: Commissioner Wallace

Voting Yea: Commissioner Cahalen, Council Member Clarke, Vice Chair Hill, Commissioner Mozumder, Commissioner Wallace

e. Capitola Wharf Enhancement Project

Report given by Vice Chair Hill on the use of public art in the CWEP group and information on the survey. Proposed the Commission consider help with fund raising by organizing a “Paint-out” outdoors timed event about the Wharf.

Motion to approve: No Action Taken

f. Summer Concerts

Report given Commissioner Wallace on the sponsorship for Twilight Concerts.

Motion to approve: No Action Taken

g. Driftwood Art Event

Report given by Commissioner Wallace on his research regarding similar events.

Commissioner Wallace suggested a division for kids and adults. Commissioner Cahalen requested meet with Public Works Director.

Motion to approve: No Action Taken

h. Commissioner Recommendation

Report given by Staff. Introduction of Jennifer Major who shared her brief history regarding volunteer events and background.

Motion to approve commissioner recommendations to next regular meeting and the City to reopen recruitment for a larger applicant pool review: Commissioner Wallace

Second: Commissioner Cahalen

Voting Yea: Commissioner Cahalen, Council Member Clarke, Vice Chair Hill, Commissioner Mozumder, Commissioner Wallace

6. Commissioner Reports None

7. Staff Reports Update on Tree Stump Project, Update on Begonia Art project, Update Monterey Railing Project, Update on T-shirts,

8. Future Agenda Items Commissioner Recommendations, Begonia Public Art Proposals, Ukrainian Art in the Park, Program Expenses, Plein Air, CWEP. For August or Later: Meet Public Work Director, Village Decoration Policy: Banner Project.

9. Adjournment The meeting was adjourned at 7:42 PM to the next regular Art & Cultural Commission meeting on July 11, 2023.

ATTEST:

Nikki Bryant LeBlond

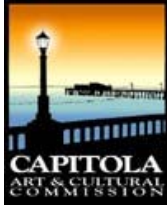

Item #: 5.a

ART & CULTURAL COMMISSION AGENDA REPORT

MEETING OF July 11, 2023

FROM: City Attorney

DATE: July 5, 2023

SUBJECT: Brown Act Training

Recommended Action: Receive Brown Act Training

BACKGROUND

The Capitola Art & Cultural Commission is an advisory body of local agency that is subject to the Brown Act.

DISCUSSION

Training provided by Samantha Zutler, City Attorney.

FISCAL IMPACT

None

ATTACHMENT

1. Brown Act Training Slides

Report Prepared By: Nikki Bryant LeBlond
Recreation Division Manager



Brown Act Training City of Capitola Art & Cultural Commission

July 11, 2023



1

The Brown Act

“Public commissions, boards and councils and the other public agencies in this State exist to aid in the conduct of the people’s business. ***It is the intent of the law that their actions be taken openly and that their deliberations be conducted openly.***”

Gov. Code § 54950



2

2

The Brown Act

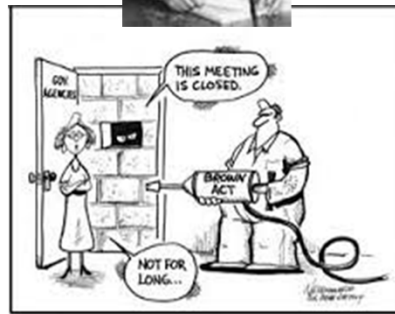

burke
BURKE, WILLIAMS & SCHREIBER LLP

3

3

The Brown Act

Basic Rule: Meetings of legislative body are covered by the Brown Act.

- What is legislative body?
 - includes standing committees or commissions
 - advisory committee made up of less than quorum is not “legislative body”
- What is a **Meeting**?
 - any gathering of a **majority of the members** of a legislative body
 - at the **same time** and location
 - to **hear, discuss, deliberate or take action** upon any item which is within its subject matter jurisdiction

burke
BURKE, WILLIAMS & SCHREIBER LLP

4

4

The Brown Act

Formal Meetings:

- Regular meetings – regular 72 hour notice required
- Special meetings – 24 hour notice required
- Emergency meetings – can be as little as 1 hour notice to media

Improper “Informal” Meetings

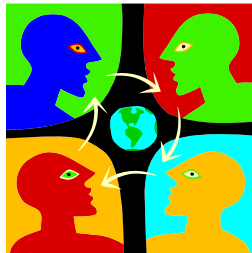

Caution: “A majority of the members of a legislative body **shall not...use a series of communications of any kind, directly or through intermediaries, to discuss, deliberate, or take action** on any item of business that is within the subject matter jurisdiction of the legislative body.

Gov. Code § 54952(b)(1)

Improper “Serial” Meeting

- **Daisy Chain**: If Member A contacts Member B, and Member B contacts Member C, and so on, until a quorum has been involved, this type of “serial meeting” may result in a violation of the Brown Act.



burke
BURKE, WILLIAMS & SCHENKER LLP

7

7

Improper “Serial” Meeting

- **Hub and spoke**: An intermediary contacts at least a quorum of the members to develop a collective concurrence on action to be taken by the legislative body.

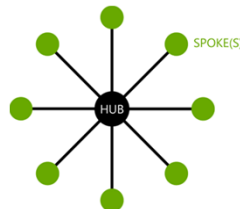

burke
BURKE, WILLIAMS & SCHENKER LLP

8

8

Improper “Technology” Meetings

- Use of e-mail or other technology/media by a majority of a legislative body to discuss, deliberate, or take action on items within the body’s jurisdiction violates the Brown Act.

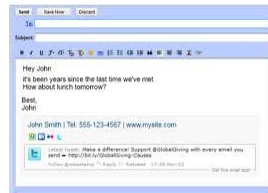

9

9

Brown Act Violations

CODE COMPLIANCE
NOTICE OF VIOLATION

- Request to Cure/Action Invalidated
- Civil Action to prevent future violations
- Costs and Attorneys’ Fees
- Criminal Charges
 - . . .where the member intends to deprive the public of information to which the member knows or has reason to know the public is entitled under this chapter, ***is guilty of a misdemeanor.***

Gov. Code § § 54959, 54960, 54960.1



10

10

Non-Agendized Items

- Action or discussion on any item not appearing on the posted agenda is generally prohibited.
- Legislative body may only:
 - Briefly respond to public statements or questions;
 - Ask a question for clarification;
 - Make a brief announcement;
 - Make a brief report on his or her activities;
 - Provide a reference to staff or other sources for factual information; or
 - Request staff to place the matter on a future agenda and report back to the legislative body in a subsequent meeting.

Gov. Code § 54954.2(a)(2)



11

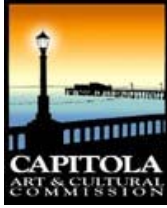

ART & CULTURAL COMMISSION AGENDA REPORT

MEETING OF July 11, 2023

FROM: STAFF
DATE: July 5, 2023
SUBJECT: Commissioner Recommendation

RECOMMENDED ACTION: Determine Commissioner Appointment recommendations to City Council for the following seats: One (1) At-Large Commissioners.

BACKGROUND

The Art & Cultural Commission consists of nine members. Due to a recent resignation the City has opened recruitment to fill one At-Large commissioner seat. The City has received four applications from Jennifer Major, Jill Payonzeck Lengre, Mario Beltramo and Neil Pearlberg to serve as an At-Large Commissioner. The individual appointed will have term through December 31, 2024.

The Capitola Municipal Code requires that the commissioners be appointed by the City Council upon recommendation by the Art & Cultural Commission and shall serve a two-year term. According to the Bylaws, members do not need to be Capitola residents. At the September 26, 2019 City Council meeting, term limits for Commissioners were removed from the Art and Cultural Bylaws.

The Commission recommendations for appointment will be set for consideration at the July 27, 2023 City Council meeting.

FISCAL IMPACT

No fiscal impact

ATTACHMENT

1. Jennifer Major Application
2. Jill Payonzeck Lengre Application
3. Mario Beltramo Application
4. Neil Pearlberg Application

Report Prepared By:

Nikki Bryant LeBlond
Recreation Division Manager



CITY of CAPITOLA BOARDS AND COMMISSIONS APPLICATION

Application for:

- Art & Cultural Commission
[Artist; Arts Professional; At Large Member]
Please underline category above.
- Architecture & Site Committee
[Architect; Landscape Architect; Historian]
Please underline category above.
- Finance Advisory Committee
[Business Representative; At Large Member]
Please underline category above.
- Traffic & Parking Commission
[Village Resident; Village Business Owner; At Large Member]
Please underline category above.
- Historical Museum Board
- Planning Commission
- Library Advisory Committee
- Other Committee _____

Name: Major Jennifer
Last First

Residential Neighborhood: Upper Hill

Occupation: Customer Experience Manager at Adobe

Describe your qualifications and interest in serving on this Board/Commission/Committee: _____

I believe that art and culture are an important part of our community and I would like to ensure that the art and cultural events thrive. I love our community and value contribution and growth.

I have 20 years of experience working with organizations and companies to manage customer programs and events. I have been a Girl Scout in our community for over 12 years, and I am also a volunteer at the SSCAS, and believe the only way to have a healthy community is to give back and contribute.

(Use additional paper, if necessary)

Please Note: Appointment to this position may require you to file a conflict of interest disclosure statement with the City Clerk. This information is a public record and these statements are available to the public on request.

06/06/2023
Date

Jennifer Major
Signature of Applicant

**Mail or Deliver Application to:
Capitola City Hall
Attn: City Clerk
420 Capitola Avenue, Capitola, CA 95010**

All information contained in this page of the application is public data and will be made available for public review and copying for anyone requesting it, and may be posted on the website of the City of Capitola. All information in this page will be provided to the Capitola City Council in a public forum and will be reviewed in public. It will therefore be part of the public record.



CITY of CAPITOLA BOARDS AND COMMISSIONS APPLICATION

Application for:

- Art & Cultural Commission
 - Artist
 - Arts Professional
 - At Large
- Finance Advisory Committee
 - Business Representative
 - At Large
- Commission on the Environment
- Historical Museum Board
- Planning Commission
- Check if applying as youth member for any board
- Other Committee _____

Name: Payonzeck Lengro Jill
Last First

Residential Neighborhood: Riverview Terrace

Occupation: Retired

Describe your qualifications and interest in serving on this Board/Commission/Committee: _____

please see attached

(Use additional paper, if necessary)

Please Note: Appointment to this position may require you to file a conflict of interest disclosure statement with the City Clerk. This information is a public record and these statements are available to the public on request.

June 13, 2023
Date

Jill Payonzeck Lengro
Signature of Applicant

All information contained in this page of the application is public data and will be made available for public review and copying for anyone requesting it and may be posted on the website of the City of Capitola. All information in this page will be provided to the Capitola City Council in a public forum and will be reviewed in public. It will therefore be part of the public record.

I am writing to express my enthusiasm to join the Arts and Cultural Commission. I believe I would be an exceptional fit for this position. I recently moved to Capitola in September 2022 and one of the reasons was not only the ocean but the cities love of the arts.

Allow me to outline the reasons why I believe I would be a good member of the Arts and Cultural Commission:

Passion for cultural diversity: I have lived in many countries (England, France, Mexico and the USA). Each country has its unique cultural heritage, traditions, and artistic expressions. I have gained firsthand exposure to diverse artistic practices, aesthetics, and perspectives and well as experiences of various cultural, social, and political contexts. I have working knowledge of French and Spanish.

Passion for the arts: Whether it's through visual art, music, dance, literature, or theater, the arts can tap into our emotions, allowing us to explore and communicate complex feelings that may be difficult to express through other means. I have enjoyed learning many different types of art forms over the years - from learning how to watercolor in France, to making alebrijes in Mexico to recently taking a jewelry making class at Cabrillo College, I am passionate about the arts. I am also a member of the California Art Club, a dynamic, member-based, nonprofit educational organization, dedicated to expanding the knowledge and appreciation of traditional fine arts in the fields of painting, drawing and sculpting.

Communication and collaboration skills: My college degree was in Interpersonal and Organizational communication. I have found the skills I learned essential for conveying ideas, building relationships, and resolving conflicts in personal and professional settings. I worked for 30+ years in marketing and customer experience roles and can apply these skills to the arts and cultural commission.

Thank you,

Jill Payonzeck Lengré



CITY of CAPITOLA

BOARDS AND COMMISSIONS APPLICATION

CITY OF CAPITOLA
CITY CLERK

JUN 14 2023

Application for:

- Art & Cultural Commission
 - Artist
 - Arts Professional
 - At Large
- Finance Advisory Committee
 - Business Representative
 - At Large
- Commission on the Environment
- Historical Museum Board
- Planning Commission
- Check if applying as youth member for any board
- Other Committee _____

Name: BELTRAMO MARIO
Last First

Residential Neighborhood: RIVERVIEW TERRACE

Occupation: RETIRED TRIAL ATTORNEY

Describe your qualifications and interest in serving on this Board/Commission/Committee:

MY WIFE, LINDA, AND I HAVE OWNED OUR RIVERVIEW DRIVE PROPERTY FOR OVER 23 YEARS, BUT HAVE ONLY BEEN FULL TIME RESIDENTS SINCE MY RETIREMENT IN 2017. OVER THESE LAST 6 YEARS I HAVE BECOME INCREASINGLY AWARE OF CAPITOLA'S UNRIVALED BEAUTY AND ITS UNIQUELY COHESIVE AND ENERGIZED POPULACE, AND BELIEVE THAT WITH THE COMMUNICATIVE SKILLS THAT I HAVE DEVELOPED OVER 40 YEARS OF PRACTICING LAW THAT I CAN HELP MAKE THE ACC BOTH EFFECTIVE & ENERGIZED.

(Use additional paper, if necessary)

Please Note: Appointment to this position may require you to file a conflict of interest disclosure statement with the City Clerk. This information is a public record and these statements are available to the public on request.

June 10, 2023
Date

Mario Beltramo
Signature of Applicant

All information contained in this page of the application is public data and will be made available for public review and copying for anyone requesting it and may be posted on the website of the City of Capitola. All information in this page will be provided to the Capitola City Council in a public forum and will be reviewed in public. It will therefore be part of the public record.



CITY of CAPITOLA BOARDS AND COMMISSIONS APPLICATION

Application for:

- Art & Cultural Commission
 - Artist
 - Arts Professional
 - At Large
- Finance Advisory Committee
 - Business Representative
 - At Large
- Commission on the Environment
- Historical Museum Board
- Planning Commission
- Check if applying as youth member for any board
- Other Committee _____

Name: _____
Last *First*

Residential Neighborhood: _____

Occupation: _____

Describe your qualifications and interest in serving on this Board/Commission/Committee: _____

(Use additional paper, if necessary)

Please Note: Appointment to this position may require you to file a conflict of interest disclosure statement with the City Clerk. This information is a public record and these statements are available to the public on request.

Date

Signature of Applicant

All information contained in this page of the application is public data and will be made available for public review and copying for anyone requesting it and may be posted on the website of the City of Capitola. All information in this page will be provided to the Capitola City Council in a public forum and will be reviewed in public. It will therefore be part of the public record.

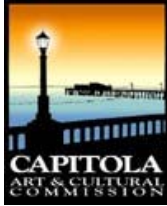

Item #: 5.c

ART & CULTURAL COMMISSION AGENDA REPORT

MEETING OF July 11, 2023

FROM: Staff
DATE: July 5, 2023
SUBJECT: Begonia Festival Commemorative Public Art Project

Recommended Action: Receive artist proposals for the Begonia Commemorative Public Art project and select one artist and concept for Council recommendation.

BACKGROUND

The Commission approved a subcommittee to work on a Public Art project for the Begonia festival and choose the park next to Soquel Creek by Stockton Ave as the installation location. The Begonia Festival has offered to contribute funds to the project. Commissioner Hill is the Chair of the subcommittee. City Council was informed about the project at the October 13, 2022 Council meeting. The Subcommittee consists of Chair Johnson, Vice Chair Hill & Commissioner Cahalen. A Call to Artist was released on March 10, 2023 for the project and the deadline for submission passed on April 30, 2023. The subcommittee was provided with all the submission for review and at the May 2023 meeting the Commission selected three artists to present a proposal for final selection.

DISCUSSION

At the May 2023 Art & Cultural regular meeting three (3) artists were selected Lea de Wit, Adrian Litman and Geoffrey Nelson. Each artist was requested to provide materials for the packet and prepare a presentation for the July 2023 meeting.

FISCAL IMPACT Project costs from the Public Art fund will be \$20,000 with a matching contribution from Beach Festival. The Public Art Fund currently has a balance of \$171,667 and the commission has \$55,500 committed to current projects.

ATTACHMENT

1. Lea de Wit Begonia Materials
2. Adrian Litman Begonia Presentation
3. Geoffrey Nelson Materials

Report Prepared By: Nikki Bryant LeBlond
Recreation Division Manager

Title: Begonia Festival Commemorative Art Project

Artist's Name: Lea de Wit

Phone Number: 760-310-7593

Email Address: info@leadewit.com

Mailing Address: 500 Bernstein Drive Boulder Creek, CA 95006

Website: <http://www.leadewit.com>



Images of Selected Previous Public Art Experience



“Catching the Light”, Santa Cruz County Library in Felton, CA



“When Dreams Take Flight”, Santa Cruz County Library in Felton, CA



“Resonate”, New York Proton Center, NYC, NY



“Imagination is Limitless”, Maryland School for the Blind, Baltimore, MD



“Resilient”, Sierra Azul Demonstration Garden, Watsonville, CA

Compilation of Begonia Shape & Color Images for Reference/ Inspiration



Proposed Concept

As a Santa Cruz County artist who enjoys making uplifting, sculptural art inspired by nature, I am excited to have the opportunity to refine my initial proposed concept for a unique, site-specific work of art that commemorates the Begonia Festival for the City of Capitola and its visitors. I have designed a vibrant and joyful art piece celebrating the beauty of begonias and the festival that was so important to the Capitola community. Since my initial proposal, I have spent time devising the best way to execute my concept by considering optimal materials and techniques to employ as well as by visiting the site.

I have further developed my design of a grouping of three colorful begonia blossoms (see attached visuals). I am proposing constructing this sculptural work out of formed, colorized, and laser cut metal. This approach will showcase the main attributes of begonias: their bright colors, their interesting patterning, and their shapes. Coating the petals in vivid tones for which these plants are known will make the piece incredibly vibrant and compelling. The laser cutting technique will create beautiful details in the petals providing depth and visual interest. These designs will change throughout each day with varying light conditions and during each season adding to the appeal of the piece. The metal petals will be formed to capture the beautiful shapes that these plants display.

The grouping of three blossoms allows for a colorful and vibrant display of the attributes of begonias while working well with the scale of the space specified. Having visited the site, I have identified a potential location but would work with the City of Capitola stakeholders to determine whether this is the most optimal spot to install the sculpture. Scale of each blossom needs to be determined once I have a full understanding of the site requirements and specifications for this project (which were not available yet during this concept development phase). At this point, with my current knowledge of the scope of the project, I am assuming approximately 3 - 4' in diameter each as I believe that works well with the space and is achievable with the budget but it will need to be further assessed. I welcome the opportunity to work with the city stakeholders to ensure that the piece works well with the site and meets all necessary codes. Also, as I understand it at this point, lighting is still a possibility and that the potential of this could be investigated further once selected to move forward.

In conclusion, I am a good fit for this project as I believe that my design celebrates the unique attributes of begonias and will resonate with the landscape and the surrounding area while being meaningful to the community. Additionally, my experience working on large-scale public art installations, along with the positive energy and wide spread appeal of my sculptural works, make me an excellent candidate for this project. It would be an honor to be commissioned to create artwork for City of Capitola and its visitors. I look forward to discussing this project in more detail at the upcoming ArtCultural Commission meeting. It is my sincere hope that I am awarded this commission as it would truly be an honor to work on a project with such meaning to the Capitola community and with this level of visibility in the county where I live and work.

Design Concept Rendering



Handwritten signature

Concept Rendering in Potential Location



View from Different Vantage Point to Illustrate Visibility



ADRIAN SUSNEA-LITMAN

Architectural Art & Design

4284 Deer Trail Rd. Santa Rosa, CA 95404

510.386.7859 adrian.artistic@gmail.com

www.adrian-susnea-litman.com

BEGONIAS BLISS

Design Option One

A commemorative, whimsical kinetic sculpture celebrating Capitola's Begonia Festival.

The 10' tall column displays various types of begonias, illustrated on fired porcelain tiles.

The kinetic top includes elements of natural habitats like bees, butterflies and hummingbirds. Fish and Sea Stars are reminiscent of the festival's Nautical Parade.

Stars and Hearts accentuate the connection to the sky and love of these precious flowers.



BEGONIAS BLISS

Design Option One

Model of the stainless steel kinetic sculpture with porcelain tiles illustrating various types of begonias



Begonias Bliss kinetic sculpture structural dimensions
Design Option One

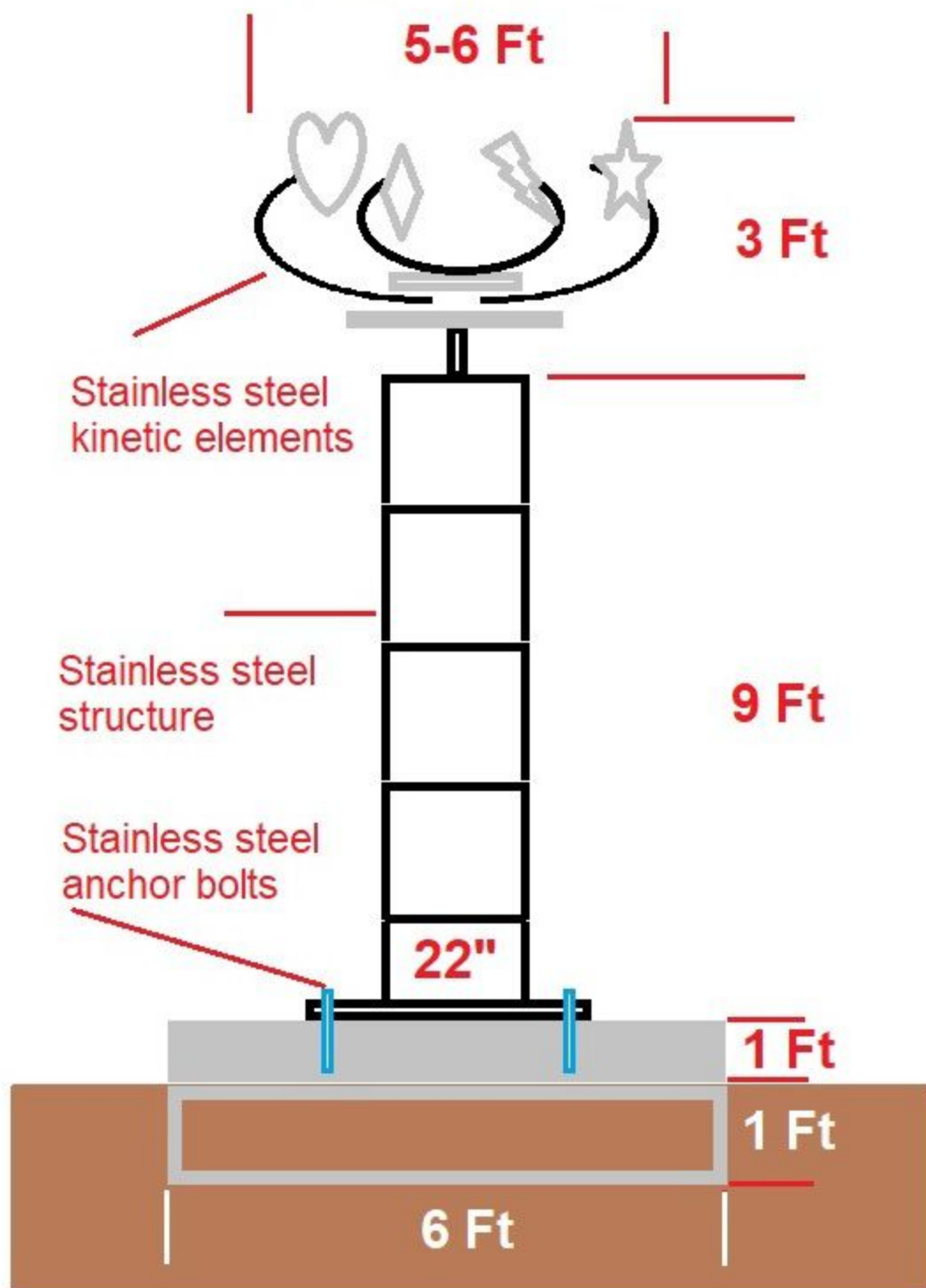

BEGONIAS BLISS

Design Option Two

The kinetic elements and begonias crown at the top of the sculpture offer less exposure to vandalism



Begonias Bliss kinetic sculpture structural dimensions

Design Option two

5-6 Ft

Stainless Steel kinetic elements

3 Ft

Top crown displaying begonia flowers on 22" x 22" tiles

Stainless Steel column
10" diameter x 9ft high

9 Ft

Stainless steel anchor bolts

1 Ft

1 Ft

6 Ft

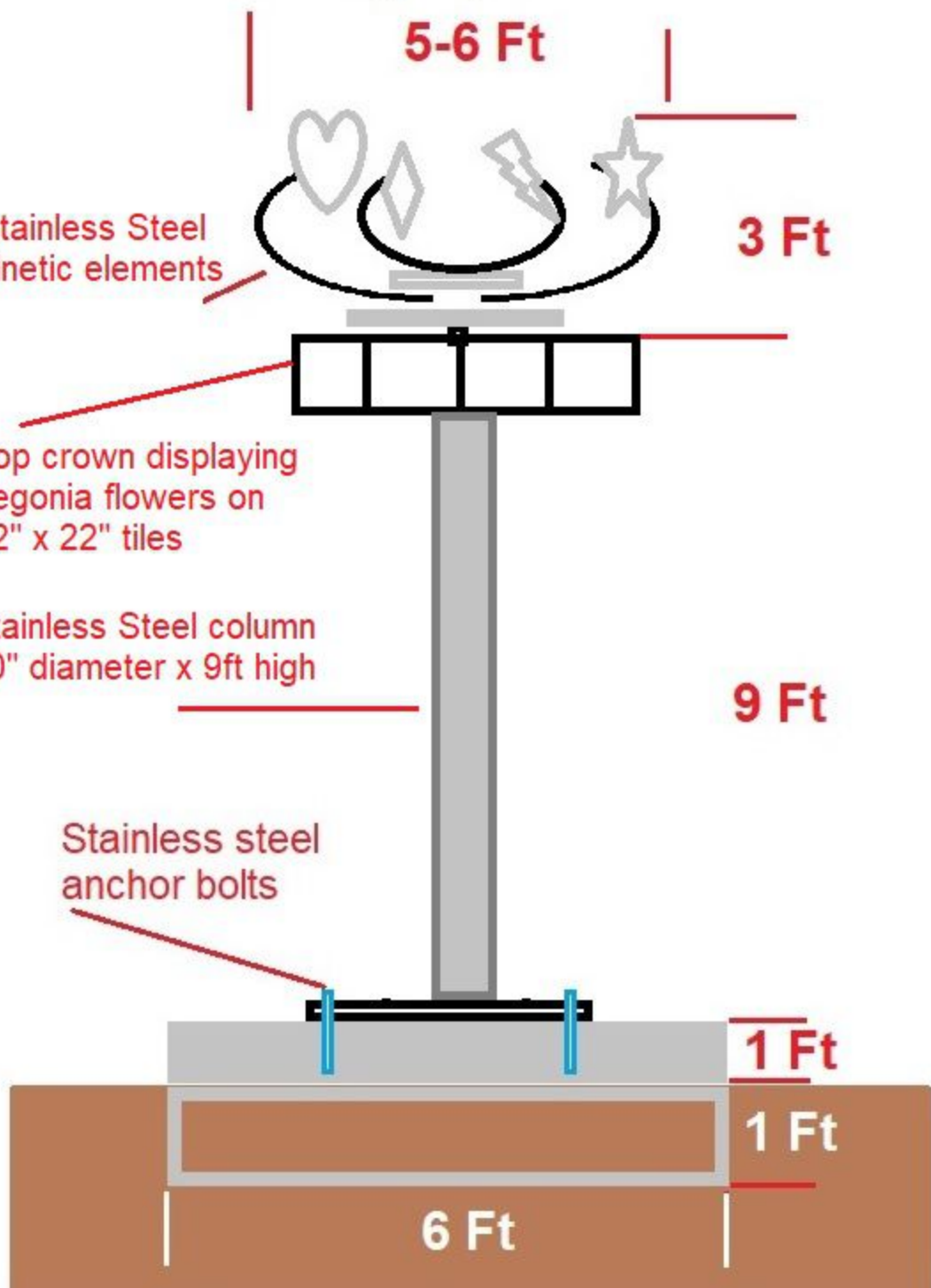

BEGONIA FIESTA

Design Option Three

Stainless Steel and glazed tiles iconic sculpture celebrating Begonias



BEGONIAS FIESTA

Design Option Three

Stainless steel, Corten and
glazed porcelain tiles



Begonias Fiesta Structural dimensions

Design Option Three

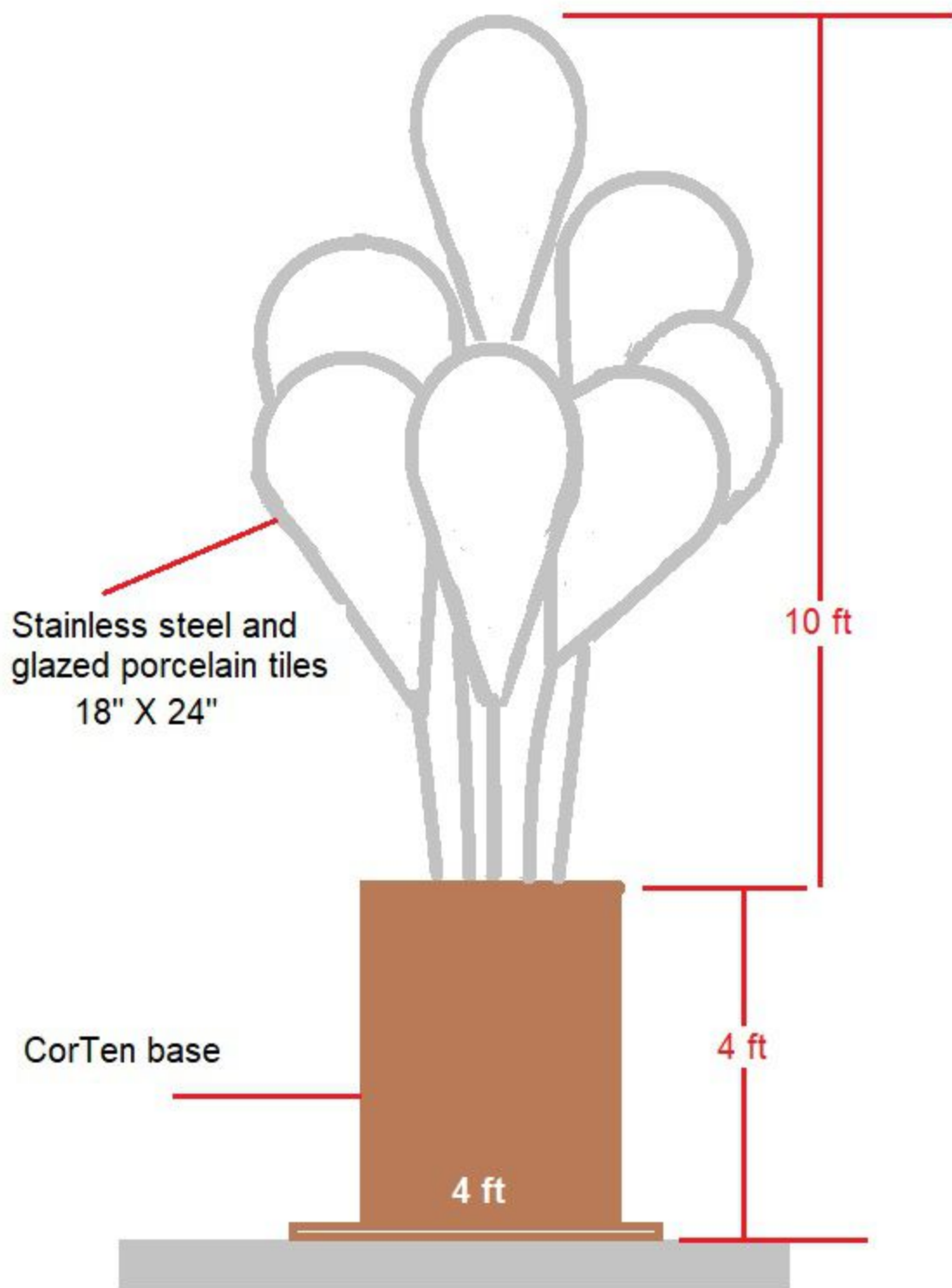

Begonia Commemorative Art Project

Geoffrey Nelson and Lynn Jaye

Project Proposal

We are proposing a beautiful three dimensional lit begonia flower for the entrance into the Village of Capitola.

This 12 foot high flower would have seven layers of petals and would be made of brushed aluminum with a light-reflecting sanded pattern.

The petals would be tinted with bright transparent colors and then coated in a durable epoxy varnish.

The colors would graduate from a deep red to an orange/red, orange and then finish in yellow keeping with the traditional colors of the begonia flowers.

As seen in the mock up photo this finish produces an effect that reflects light in a dynamic way during the day.

At night the flower would softly glow from within with color changing waterproof LED's that will create a beautiful color morphing art piece.

Each layer of petals will have its own color changing pattern. With this mesmerizing and dramatic lighting this piece will be just as beautiful at night as it is during the day.

The flower will be held by a "stem" made of tapered metal that will be structurally engineered to withstand any sort of wind. It will be bolted to a concrete base and all the electrical components will be accessible through a small door at the base.

The LED's are rated for 50,000 hours, which at 6 hours a day would be a 22 year lifespan. There would be a set of 2 LED strips on each side to make sure if anything happened to one the other would still be lit. The LED strips would be waterproof and would be easy to replace.

It will rest on a small concrete platform.

Rising from the garden that is the entrance to the Village this piece will commemorate the Begonia festival and the beautiful flower that was the heart of the event.

We believe it will also become a great spot for self portraits as well a favorite of Instagramers











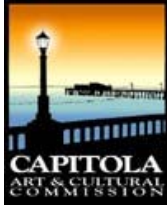

Item #: 5.d

ART & CULTURAL COMMISSION AGENDA REPORT

MEETING OF July 11, 2023

FROM: STAFF
DATE: July 5, 2023
SUBJECT: Art & Cultural program expenses and processing

Recommended Action: Receive report on process for purchasing for program.

BACKGROUND

The Capitola Art & Cultural Commission operates within two different budgets. The first is a general fund program budget that details income and expenditure for all events the commission produces throughout the year. The second is the Public Art Special Revenue Fund which is restricted for the use of Public Art projects the commission identifies and vets' to occur with the budget year.

DISCUSSION

The Art & Cultural Program budget has revenue and expense accounts for each program offered: Twilight Concerts, Movies at the Beach, Art at the Beach. One new revenue account will be added for Plein Air and include detailed expenses (i.e., contract services, supplies) However, for Plein Air at the end of each fiscal year the revenue in excess of the expenditures will move to a deposit account so that the funds remain with the Art & Culture program budget. This is similar to how donations are tracked for the City Museum activity.

With the elimination of the Friends Checking Account all expense and income activity will be done under the purchasing authority of Staff using the standard invoicing and reimbursement policies of the City. Staff will provide quarterly financial reports to the committee on the following tentative schedule: Oct. (July – Sept.), Jan. (Oct. – Dec.), April (Jan. – Mar.), and July (Apr. – June) as well as the July – June annual financial report.

FISCAL IMPACT

The Friends Checking account will be deposited into the City Fund and used for Plein Air related expenses as well as other Art & Cultural Committee directed activities subject to availability of funds.

ATTACHMENT

Report Prepared By: Nikki Bryant LeBlond
Recreation Division Manager

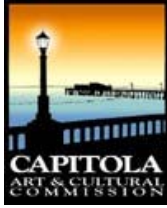

Item #: 5.e

ART & CULTURAL COMMISSION AGENDA REPORT

MEETING OF July 11, 2023

FROM: Commissioner Hill
DATE: July 5, 2023
SUBJECT: Ukrainian Art in the Park

Recommended Action: Receive Commissioner Hills Report

BACKGROUND

Commissioner Hill proposed adding a cultural event to the Art in the Park series produced by the Art & Cultural Commission. Commissioner Hill has identified champion Natalia Aandewiel who would be the primary partner for this event. The Commission approved the addition of this event for the 2023 summer calendar and allocated \$2000 for expenses related to the event.

The subcommittee consists of Vice Chair Hill, Commissioner Cahalen and Commissioner Wallace.

DISCUSSION

Commissioner Hill to provide update on event progress. Kelly Barreto is processing the Special Event Permit for August 26, 2023.

FISCAL IMPACT

ATTACHMENT

Report Prepared By: Nikki Bryant LeBlond
Recreation Division Manager

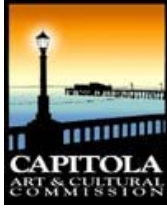

Item #: 5.f

ART & CULTURAL COMMISSION AGENDA REPORT

MEETING OF July 11, 2023

FROM: Vice Chair Hill

DATE: July 5, 2023

SUBJECT: Plein Air

Recommended Action: Receive report from Vice Chair Hill and appoint additional subcommittee members.

BACKGROUND

The Capitola Plein Air event is a seven-year-old event planned for October 30 to November 5, 2023 with an exhibition to take place at the Capitola Community Center.

Vice Chair Hill serves as the Plein Air subcommittee chair.

DISCUSSION

Receive updates from Vice Chair Hill.

FISCAL IMPACT

The Plein Air event will be tracked in the FY 2023/24 budget as other similar Art & Cultural Commission events.

ATTACHMENT

Report Prepared By: Nikki Bryant LeBlond
Recreation Division Manager

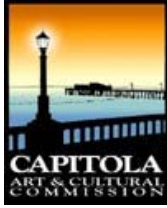

Item #: 5.g

ART & CULTURAL COMMISSION AGENDA REPORT

MEETING OF July 11, 2023

FROM: Vice Chair Hill
DATE: July 5, 2023
SUBJECT: Wharf Enhancement Kickoff Event

Recommended Action: Receive Commissioner Hills Report

BACKGROUND

Commissioner Hill added this item to the agenda during the April 2023 meeting.

DISCUSSION

Consider Capitola Wharf Enhancement Project and identify intent of Commission's involvement.

FISCAL IMPACT

ATTACHMENT

Report Prepared By: Nikki Bryant LeBlond
Recreation Division Manager