



CAPITOLA

ART & CULTURAL COMMISSION

MEETING AGENDA

Tuesday, April 11, 2017

6:30 p.m.

Capitola Council Chambers

Commission Members

Michael Termini ~ Chair

Nathan Cross~ Vice Chair

Mary Beth Cahalen

Mary Jo Connoly

Laurie Hill

Kim Hogan

Dennis Norton

Sam Storey

- 1. Call to Order-Roll Call**
- 2. Approval of Agenda-**
- 3. Oral Communications-**
- 4. Approval of Minutes- March 14, 2017**
- 5. General Business –**
 - a. Esplanade Park**
 - b. Capitola Railing Proposals**
 - c. Plein Air**
 - d. Merchandise Inventory (Verbal)**
- 6. Commissioner Reports-**
- 7. Staff Report-**
- 8. Communications-**
- 9. Future Agenda Items –**
- 10. Adjournment**

Notice: The Art and Cultural Commission meets on the second Tuesday at 6:30 PM in the City Council Chambers located at 420 Capitola Avenue, Capitola.

Staff Representatives

Kelly Barreto &
Larry Laurent

Agenda and Agenda Packet Materials: The Art and Cultural Commission Agenda is available on the City's website: www.cityofcapitola.org/ on Friday prior to the Tuesday meeting. If you need additional information please contact the City Hall Department at (831) 475-7300.

Americans with Disabilities Act: Disability-related aids or services are available to enable persons with a disability to participate in this meeting consistent with the Federal Americans with Disabilities Act of 1990. Assisted listening devices are available for individuals with hearing impairments at the meeting in the City Council Chambers. Should you require special accommodations to participate in the meeting due to a disability, please contact the City Clerk's office at least 24-hours in advance of the meeting at 831-475-7300. In an effort to accommodate individuals with environmental sensitivities, attendees are requested to refrain from wearing perfumes and other scented products.

Appeals: Any person who believes that a final action of this advisory body has been taken in error may appeal that decision to the City Council. Appeals must be in writing and delivered to the City Clerk's Office within ten (10) working days from the time of the boards' decision. The notice of appeal shall set forth appellant's name, phone number, address to which notices may be sent to the appellant, and the grounds upon which the appeal is made.

CAPITOLA

ART & CULTURAL COMMISSION

DRAFT MEETING MINUTES

Tuesday, March 14, 2017 6:30 p.m.

City Council Chambers

1. **Call to Order-Roll Call:** Present: Termini, Hill, Hogan, Smith, Cahalen, Cross, Storey
Absent: Norton
2. **Approval of Agenda-** M/S Storey/Cahalen Approved Unanimously
3. **Oral Communications-** Commissioner Hill asked about retaining wall on Park and Washburn. Elaine Kennedy with Art of Santa Cruz in the Capitola Mall discussed the restarting of the third Friday event at the Capitola Mall. Staff will send application for banner.
4. **Approval of February 14, 2017 Minutes-** M/S Termini/Storey. Approved unanimously
5. **General Business-**
 - a. **Capitola Ave Railing** Staff reported that the two finalists for the Capitola Avenue Railing will be presenting proposals at the April 11th meeting, not April 14th as stated in the written staff report.
 - b. **Public Art Bylaws and Budget** Chair Termini asked about the temporary section under the definition of Artwork and it may be an Art Commission interpretation. Commissioner Hill asked if Plein Air would be considered public art administration. Chair Termini suggested that a subcommittee review the code. Commissioner Storey ask the purpose of the review. Chair Termini felt that it was to have someone not associated with the commission can understand the code. Chair Termini nominated Commissioner Story as chair of subcommittee. Staff will email commission to see who else wants to be on subcommittee. Commissioner Storey asked about the budget. Staff will review.
 - c. **Retreat Notes** Staff presented notes from retreat. Commissioner Cross felt that the facilitator was a good fit for the commission. Requested that a list be made of short term ideas and works in progress.
 - d. **Plein Air** Commissioner Hill wants to be able to get a commitment that the commission and the City are behind to the Plein Air event. Chair Termini stated that there might be a possibility to use public art funding. Moving forward possibly look to being general fund neutral. Staff will speak with Jenny Shelton about 2017 event.
 - e. **Sponsorship Committee** Chair Termini and Commissioner Norton will reach out for sponsors.
 - f. **Esplanade Park** Staff reported that the contract for the Esplanade Park signed. Commissioner Cross requested that staff work with Mr. Arnone to get the footprint and height of the climbing sculpture identified. It was requested that this be brought to the April meeting.
6. **Commissioner Reports** – Movie Selection committee is trying to get Chasing Mavericks. Staff will follow up to see about availability. Commissioner Hill reported that the Skate Park mural sub-committee had its first meeting and will meet again
7. **Staff Report-** None
8. **Communications-** None
9. **Future Agenda Items** – Public Art ordinance review sub-committee, Plein Air Contract. Vision and Mission, Climbing Sculpture.

10. Adjournment M/S MT/SS Approved Unanimously

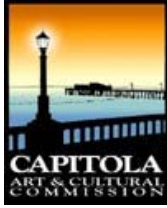

Item #: 5.a

ART & CULTURAL COMMISSION AGENDA REPORT

MEETING OF APRIL 11, 2017

FROM: STAFF
DATE: April 3, 2017
SUBJECT: Esplanade Park

Recommended Action: Receive Report and Give Direction

BACKGROUND

At the February 9, 2017 City Council meeting, the City Council approved the use of Public Art funds to create an Esplanade Park Master plan and for the climbing sculpture element of the plan.

The Council gave direction to move forward with the climbing sculpture prior to the completion of the Esplanade Park Master Plan

Mike Arnone will present options for the location and size of the climbing sculpture. The Commission will need to form a subcommittee and create a call to artist for the sculpture.

FISCAL IMPACT The recommended size of the sculpture will affect the budget of the sculpture. It is anticipated that the budget will be less than \$50,000.

ATTACHMENT

Esplanade Park
4x4 Option
5' Diameter Option
6 x 8 Option

Report Prepared By: Larry Laurent
Assistant to the City Manager

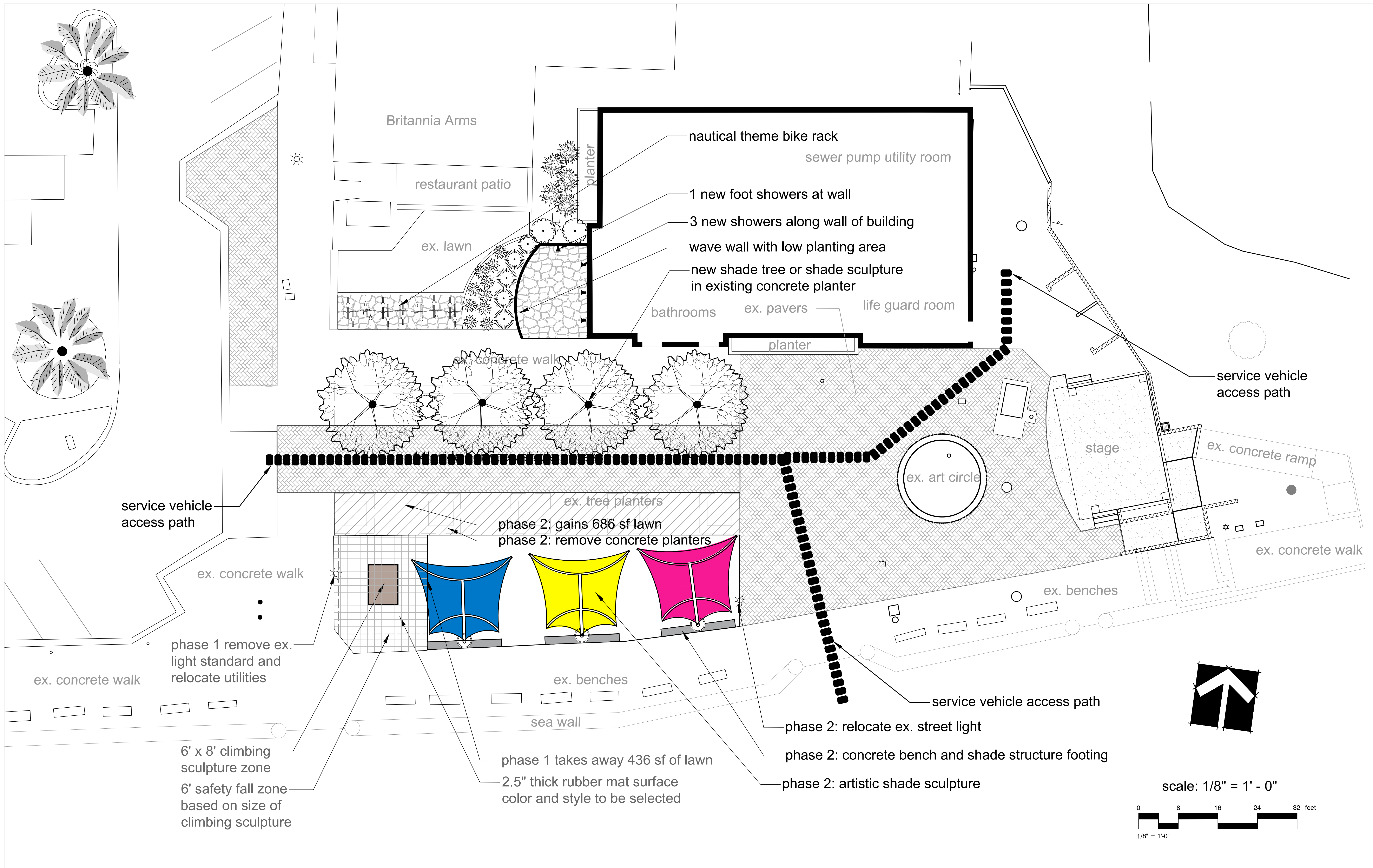

existing planter

4' X 4' structure

safety zone
surface

6' fall zone

SCALE $\frac{1}{4}'' = 1' - 0''$

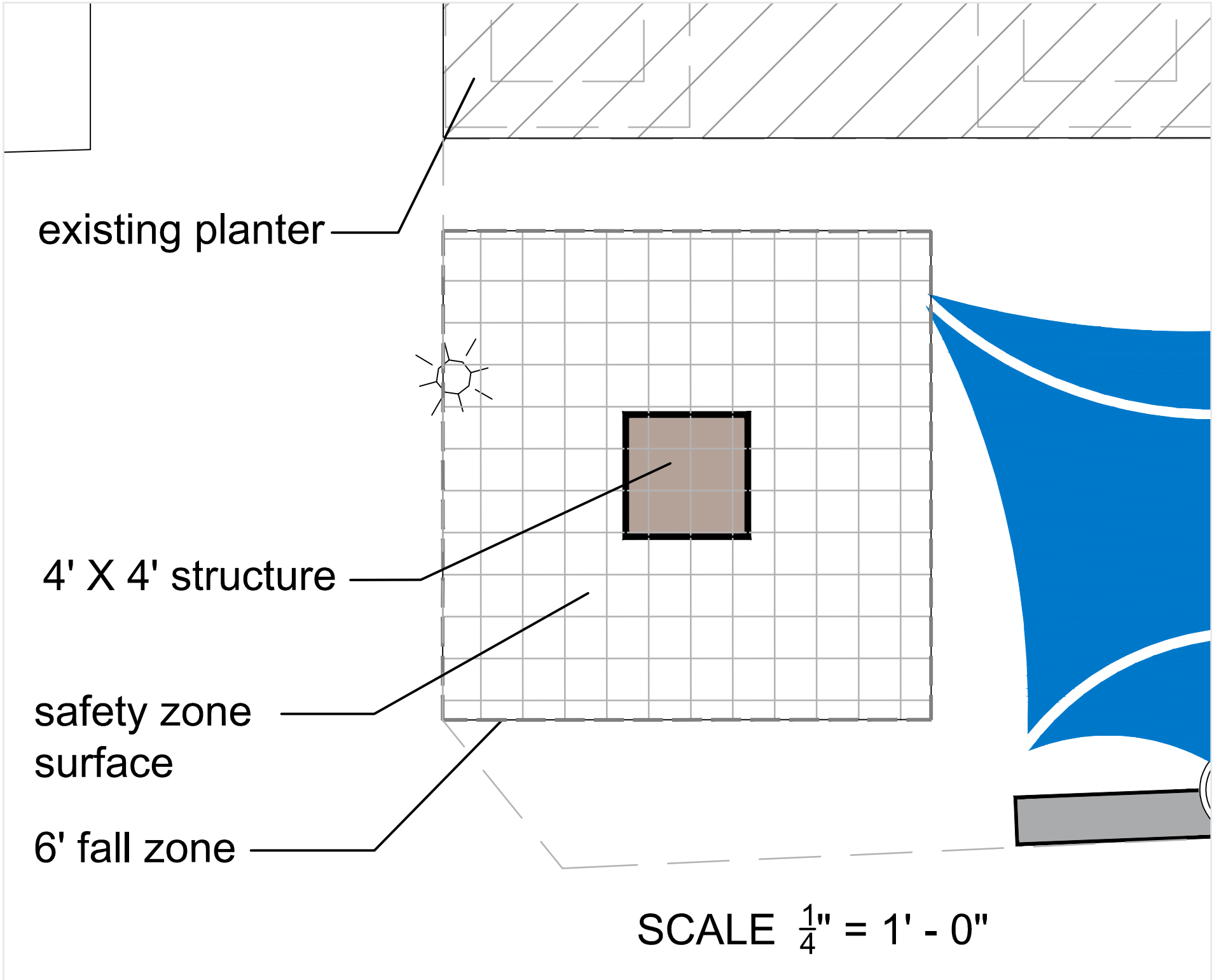
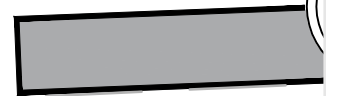
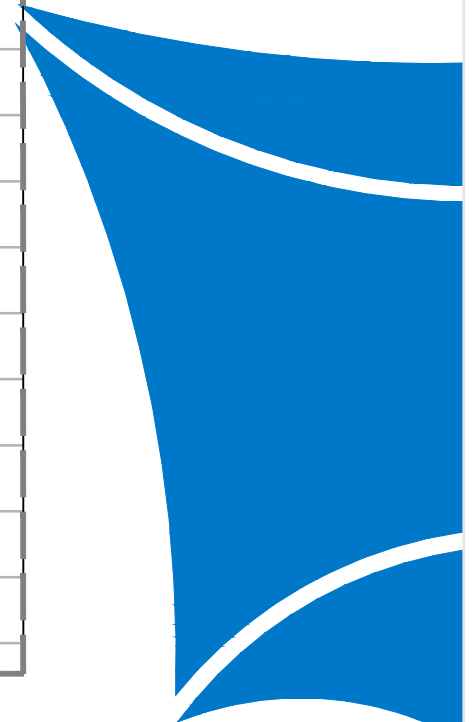
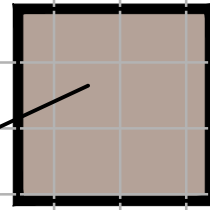
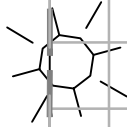

existing planter

5' diameter structure

safety zone surface

6' fall zone

SCALE $\frac{1}{4}'' = 1' - 0''$

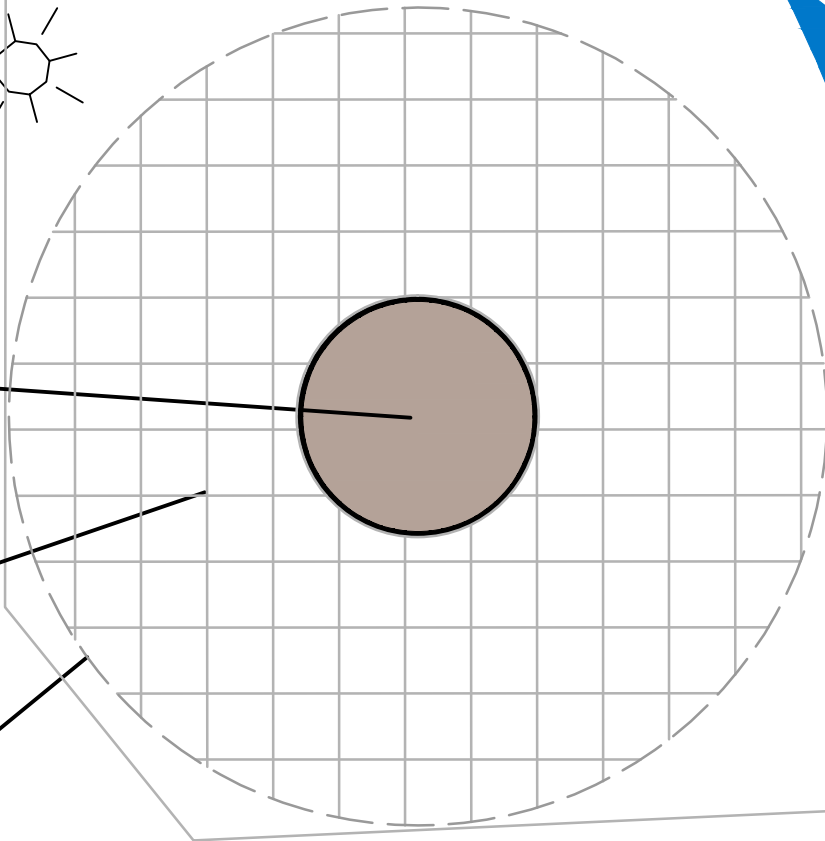
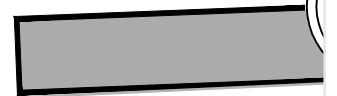
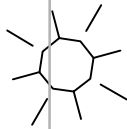

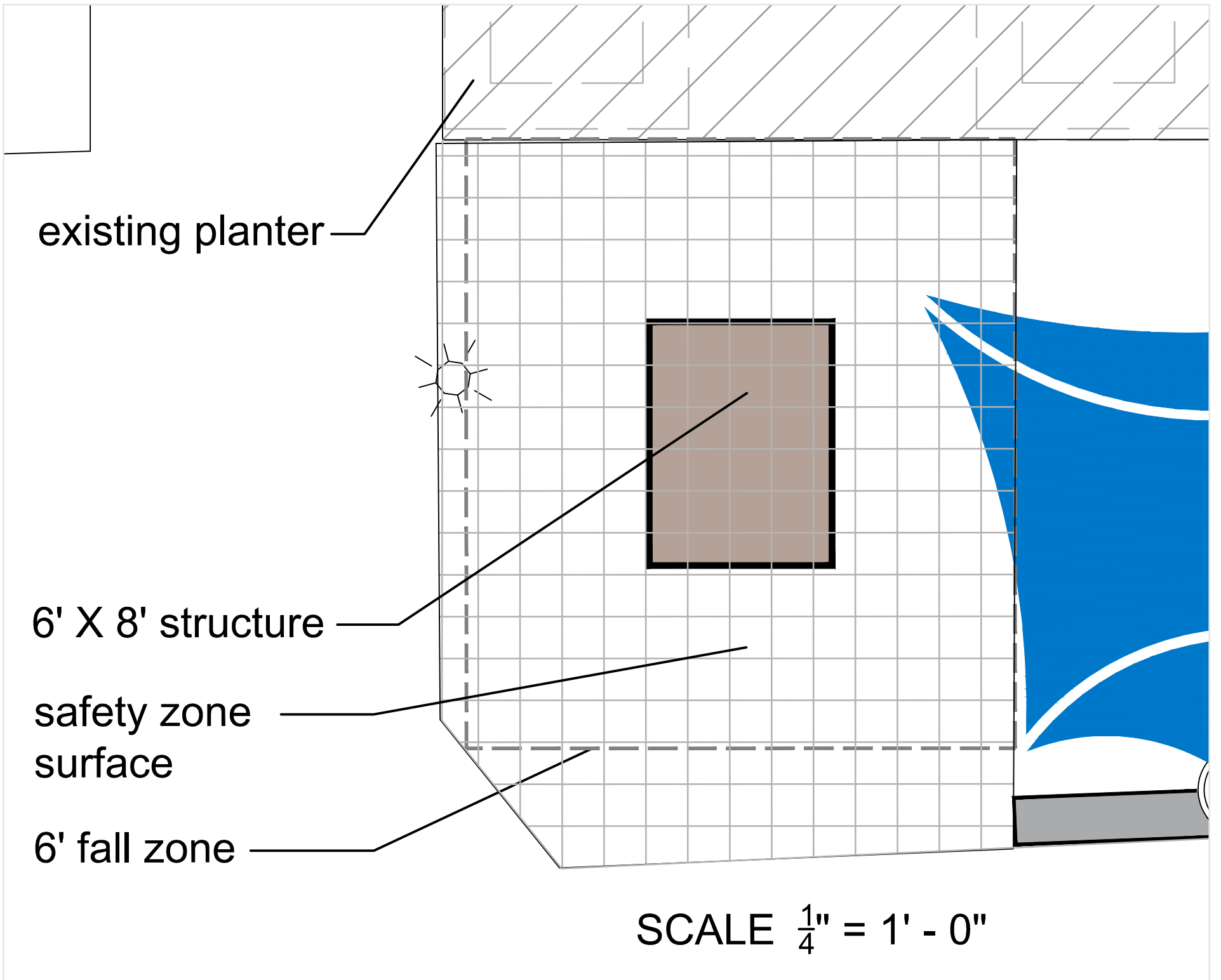

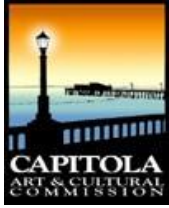

Item #: 5.a

ART & CULTURAL COMMISSION AGENDA REPORT

MEETING OF APRIL 11, 2017

FROM: STAFF
DATE: April 3, 2017
SUBJECT: Capitola Avenue Railing

Recommended Action: Receive Presentations

BACKGROUND

At the February 14th, 2017 meeting the Art and Cultural reviewed the recommendations of the Capitola Avenue Railing Subcommittee. The Commission requested that staff arrange for presentations from two finalists; Sculptural Accents (Lois and Ernest Rich) and Mike Reigel.

The Commission receive presentation and action will be taken at the May meeting after all commissioner have had an opportunity to review the proposal.

FISCAL IMPACT Each artist will be paid a stipend of \$500.00 dollars will be given for their proposal.

ATTACHMENT

Report Prepared By: Larry Laurent
Assistant to the City Manager

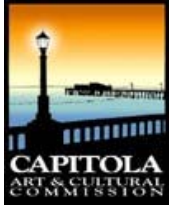

Item #: 5.a

ART & CULTURAL COMMISSION AGENDA REPORT

MEETING OF APRIL 11, 2017

FROM: STAFF
DATE: April 3, 2017
SUBJECT: Plein Air

Recommended Action: Receive Report and Give Direction

BACKGROUND

At the March 14, 2017 meeting, the Commission directed staff to begin discussions with former commissioner, Jenny Shelton, on the possibility of running the Plein Air event in 2017. Ms. Shelton has been deeply involved in the event for the first two years of its existence. In 2016, she was the chair of the Plein Air committee. In 2016, the event expanded and required more time and effort to coordinate.

Based on the time and effort required to put on the event, staff believes that it would be best to contract with Ms. Shelton so that Plein Air continues. Ms. Shelton has given the City an estimate of \$3000 to coordinate and run Plein Air. Ms. Shelton estimates that the event will require approximate 200 hours of her time.

Ms. Shelton would be responsible for planning, marketing, securing sponsors, and running the Plein Air event. The plan and work will be coordinated through the Plein Air sub-committee, with members of the Art and Cultural Commission. The workplan and expenses for the event will need to be approved by the sub-committee.

The 2016 Plein Air event had expenses of approximately \$10800 of which the City Budgeted \$3500 from the general fund and \$2300 from the public art fund to acquire the winning paintings for the city's permanent collection. Revenues for the 2016 event were \$8000.

FISCAL IMPACT The proposed agreement to run the Plein Air event will be for \$3000 plus approved expenses.

ATTACHMENT

Report Prepared By: Larry Laurent
Assistant to the City Manager